

CUT SLOPES - 3:1 OR FLATTER

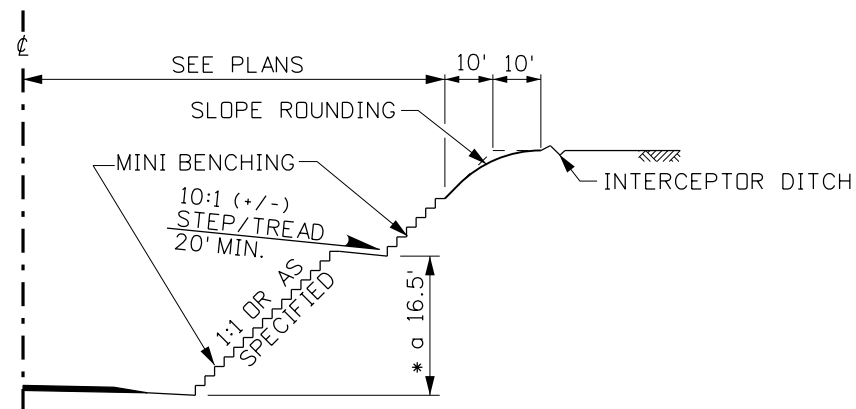

RIPPABLE ROCK CUT - 1:1 OR AS SPECIFIED

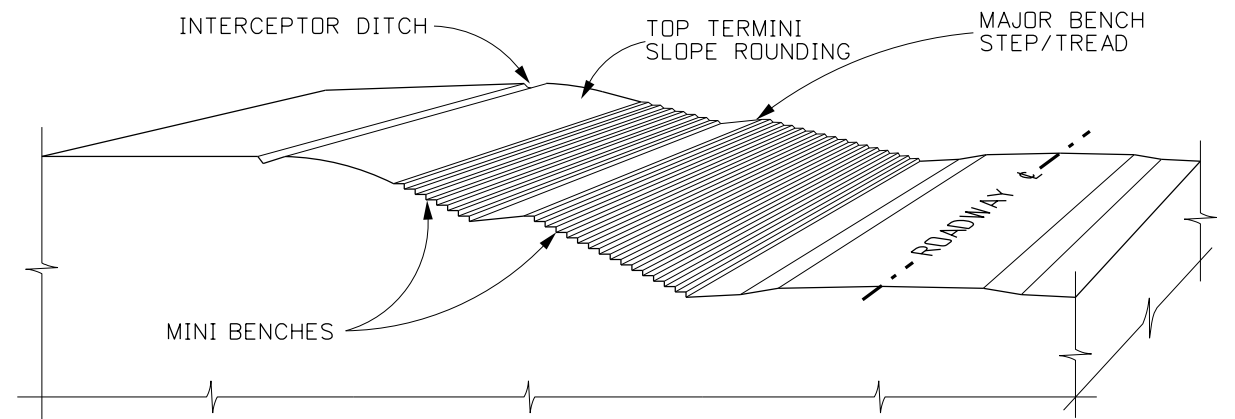

PERSPECTIVE VIEW - ROADSIDE SLOPE TREATMENT

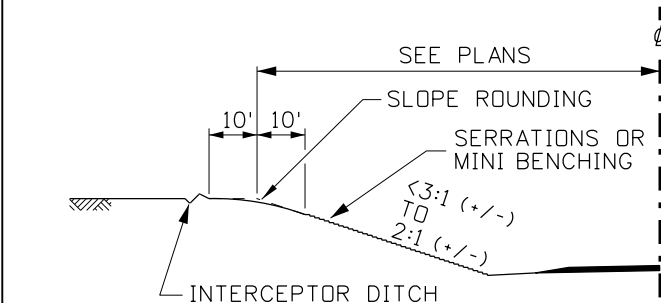

CUT SLOPES - STEEPER THAN 3:1 TO 2:1

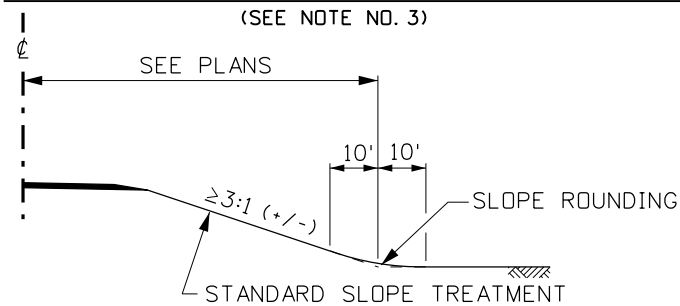

FILL SLOPES - 3:1 OR FLATTER

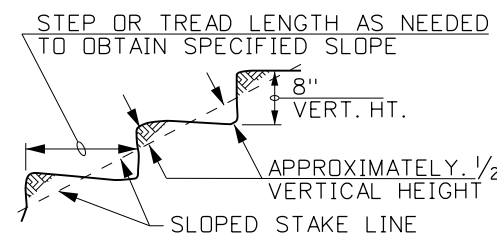

SERRATION DETAIL
(SEE NOTE NOS. 2 & 6)

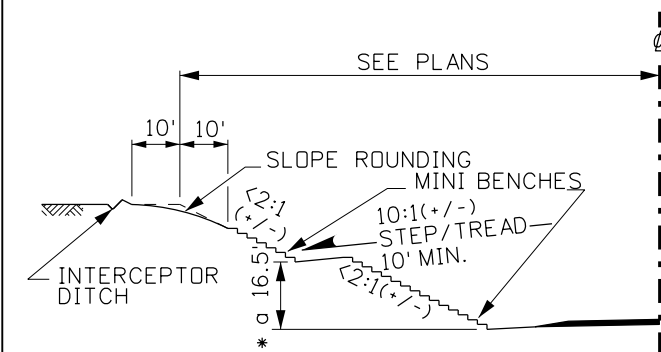

CUT SLOPES - 2:1 OR STEEPER
(SEE NOTE NO. 3)

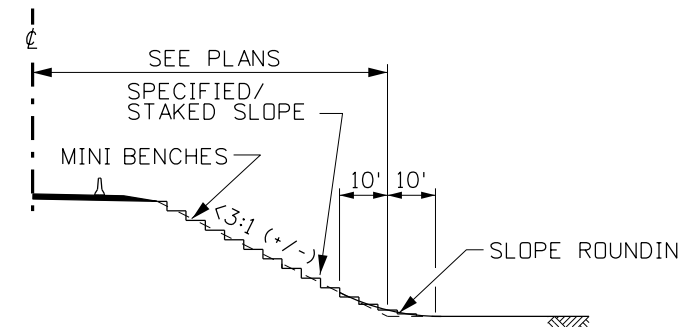

FILL SLOPES - STEEPER THAN 3:1
(SEE NOTE NO. 3)

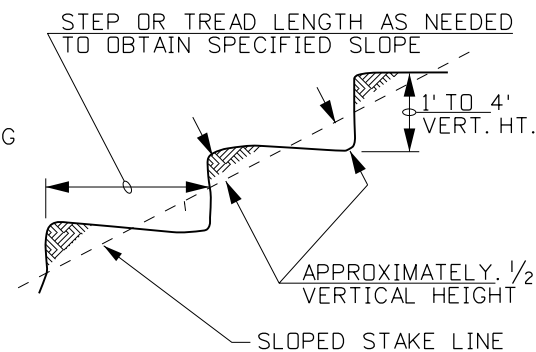

MINI BENCH DETAIL
(SEE NOTE NOS. 2 & 6)

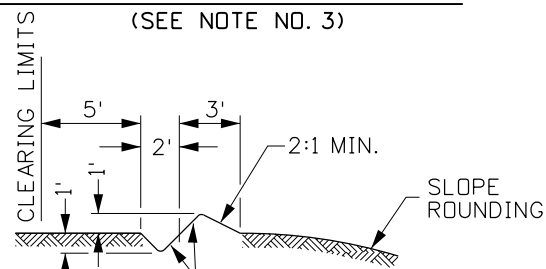

INTERCEPTOR DITCH
(SEE NOTE NO. 8)

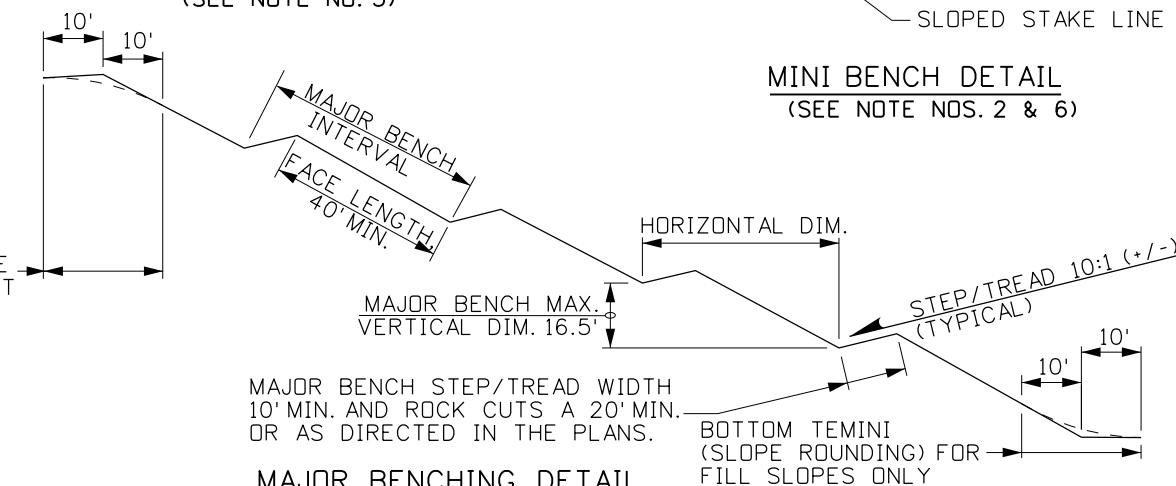

MAJOR BENCHING DETAIL
(SEE NOTE NOS. 3 & 6)

NOTES

- SERRATION VERTICAL DIMENSIONS ARE APPROXIMATELY 1 FOOT OR LESS. MINI BENCH VERTICAL DIMENSIONS ARE APPROXIMATELY 1 FOOT TO 4 FEET. MAJOR BENCH VERTICAL DIMENSIONS ARE GREATER THAN 4 FEET. THE FACE OF MAJOR BENCHING SHALL BE CONSTRUCTED AT THE SPECIFIED SLOPE.
- CUT SLOPES STEEPER THAN 3:1 TO <math>< 2:1</math> SHALL HAVE SERRATING OR MINI BENCHING. CUT SLOPES OF 2:1 OR STEEPER AND FILL SLOPES OF 3:1 OR STEEPER SHALL HAVE MINI BENCHING. SERRATION AND MINI BENCHING IS OPTIONAL ON CUT AND FILL SLOPES OF 3:1 OR FLATTER.
- MAJOR BENCHING IS REQUIRED ON RIPPABLE ROCK CUTS, CUT SLOPES 2:1 OR STEEPER, AND IS OPTIONAL ON FILL SLOPES STEEPER THAN 3:1. ONLY THE FACE PORTION OF MAJOR BENCHING MAY HAVE SERRATING OR MINI BENCHING. ALL MAJOR BENCHING CONFIGURATIONS SHALL BE DETAILED IN THE PLANS.
- ALL SLOPE TREATMENT SHALL INCLUDE TOP AND/OR BOTTOM TERMINI. NORMALLY ALL TOP TERMINI FOR CUTS AND BOTTOM TERMINI FOR FILLS WILL CONSIST OF THE STANDARD SLOPE ROUNDING WITH TWO OR MORE 10 FOOT CHORDS. THE ROUNDING SHALL BE AS GENEROUS AS PRACTICAL.
- SLOPES CONSTRUCTED WITH SERRATIONS, MINI BENCHING, AND/OR MAJOR BENCHING SHALL FOLLOW CONTOURS IN DRY ZONES OR A NON-EROSIVE LATERAL GRADE IN WET ZONES. FOR HELP DETERMINING A NON-EROSIVE LATERAL GRADE, CONTACT THE ITD MATERIALS SECTION.
- INSTALLATION OF PERMANENT EROSION CONTROL SEDIMENT TRAPPING DEVICES ARE REQUIRED AT THE DRAINAGE OUTLET(S) OF SERRATIONS, MINI BENCHING, AND MAJOR BENCHING STEPS/TREADS WHICH ARE NOT ON A LATERAL OR FLAT GRADE. THE STEPS/TREADS ON ALL SLOPE TREATMENT APPLICATIONS SHALL DIRECT THE INITIAL RUNOFF INTO THE CUT/FILL.
- WHERE ERODIBLE SOILS (SILT AND/OR CLAY WITH NO GRAVEL OR ROCK) ARE PRESENT, SLOPES SHALL BE LEFT SMOOTH AND COVERED WITH EROSION CONTROL BLANKETS AS REQUIRED ON ITD BEST MANAGEMENT PRACTICES.
- WHEN INTERCEPTOR DITCHES ARE USED IN CONJUNCTION WITH ROADSIDE SLOPE TREATMENT THE DIMENSIONS GIVEN IN THE "INTERCEPTOR DITCH DETAIL" SHALL BE USED (NOTE: INTERCEPTOR DITCH IS A STANDARD PAY ITEM). THE CONFIGURATION OF INTERCEPTOR DITCHES USED IN CONJUNCTION WITH ROADSIDE TREATMENT DEVICES SHALL BE DETAILED ON THE PLANS.
- NOT TO SCALE.

REVISIONS			
NO.	DATE	BY	DESCRIPTION

DESIGNED	
DESIGN CHECKED	
DETAILED	
DRAWING CHECKED	

SCALES SHOWN ARE FOR 11" X 17" PRINTS ONLY
CADD FILE NAME
DRAWING DATE:

IDAHO TRANSPORTATION DEPARTMENT



PROJECT NO.	
-------------	--

STANDARD DETAIL A-6
TYPICAL ROADSIDE SLOPE TREATMENT

English
COUNTY
KEY NUMBER
SHEET 1 OF 1

NOT APPROVED
PRELIMINARY
FOR CONSTRUCTION