

W-BEAM LAPPING DETAILS
(STANDARD WOOD POST INSTALLATION SHOWN)

STANDARD POST, BLOCKOUT, & RAIL INSTALLATION

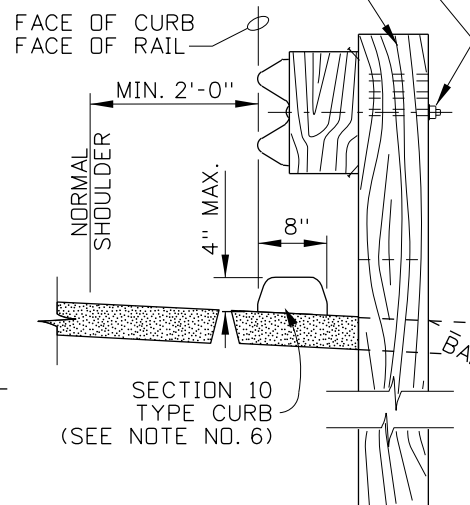

STANDARD GUARDRAIL INSTALLATION
(SEE NOTE NO. 5)

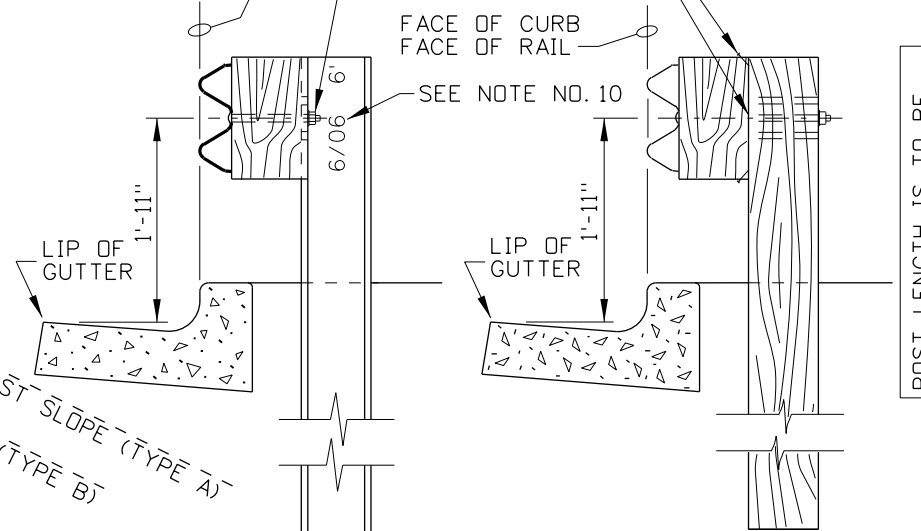

CURB ONLY

STEEL POST

WOOD POST

CURB & GUTTER INSTALLATION WITH GUARDRAIL

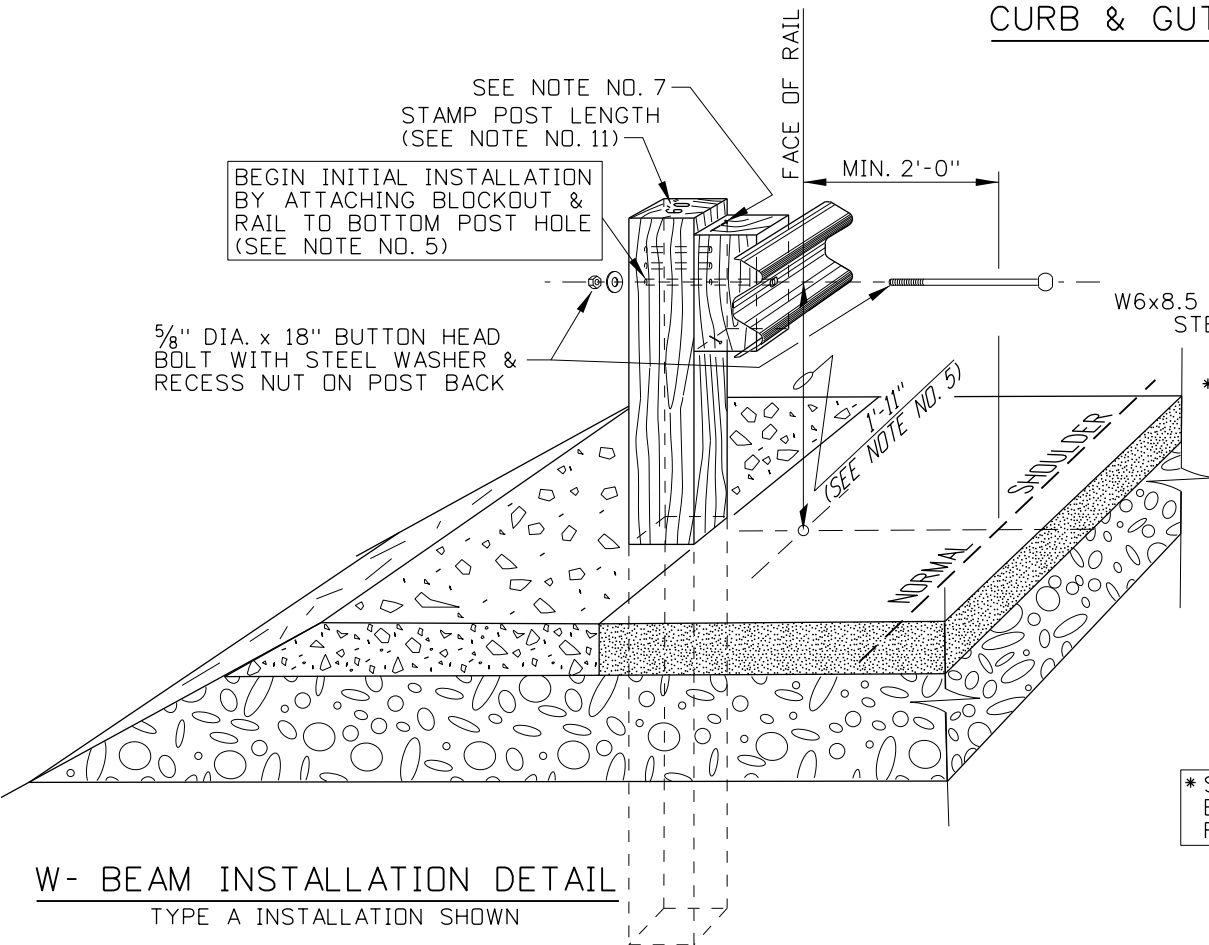

W-BEAM INSTALLATION DETAIL
TYPE A INSTALLATION SHOWN

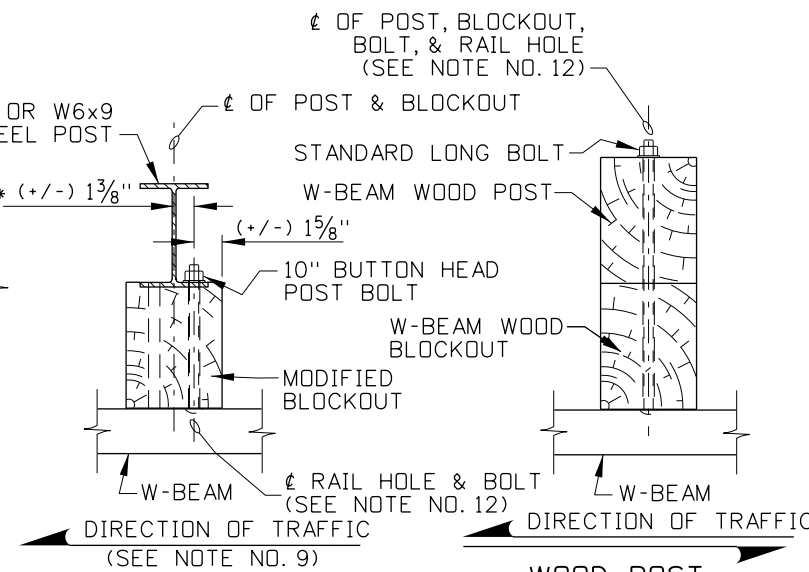

STEEL POST

WOOD POST

W-BEAM BOLTING DETAILS

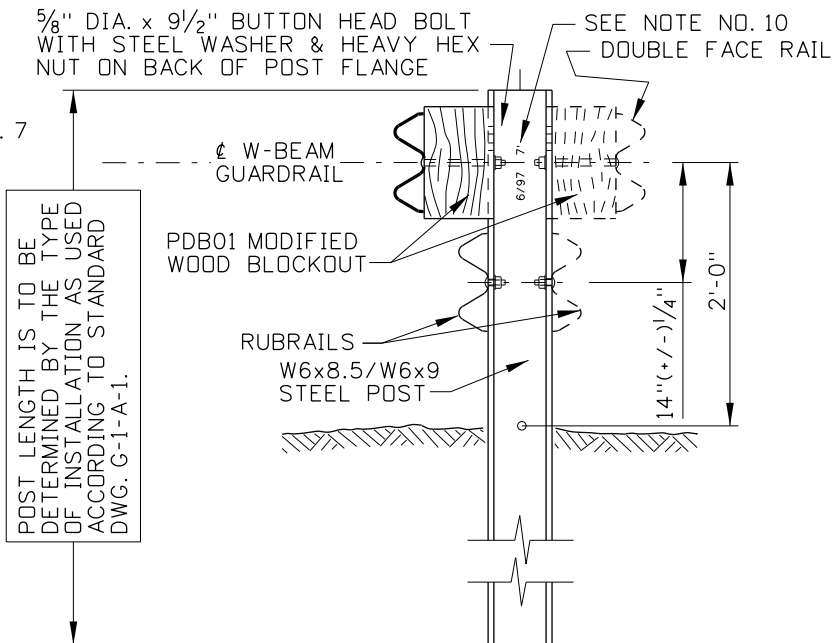

MEDIAN BARRIER DETAIL

NOTES

1. STEEL GUARDRAIL POSTS SHALL CONFORM TO THE "SPECIFICATIONS" OF THE WIDE-FLANGE GUARDRAIL POST (PWE01-04) IN THE "A GUIDE TO STANDARDIZED HIGHWAY BARRIER HARDWARE".
2. ALL W-BEAM METAL GUARDRAIL WILL BEGIN AND END WITH A TERMINAL.
3. A SINGLE W-BEAM GUARDRAIL INSTALLATION: POSTS MAY BE WOOD OR STEEL, HOWEVER THE LINE POSTS SHALL BE CONTIGUOUS OF EITHER WOOD OR STEEL. WOOD POSTS SHALL BE OF CONTIGUOUS SIZES SUCH AS, 6"x8" POSTS WITH 6"x8" BLOCKOUTS OR WITH 8"x8" POSTS WITH 8"x8" BLOCKOUTS. BLOCKOUT MATERIAL MAY VARY (REFER TO STD. DWG. G-1-A-3).
4. W-BEAM METAL GUARDRAIL SHALL BE LAPPED IN THE DIRECTION OF TRAFFIC TO PREVENT RAIL SNAGGING.
5. INITIAL RAIL AND BLOCKOUT BOLTING TO THE POST SHALL BEGIN IN THE LOWEST POST HOLE FOR BOTH WOOD AND STEEL POSTS EXCEPT FOR URBAN CURB AND GUTTER INSTALLATIONS (SEE NOTE NO. 7). SUBSEQUENTLY THE RAIL AND BLOCKOUT SHOULD BE RAISED IN CONJUNCTION WITH THE RISE OF THE PAVEMENT SURFACE DUE TO OVERLAYS AND SEAL COATS. NORMALLY RAISING SHOULD OCCUR WHEN THE VERTICAL DISTANCE IS LESS THAN 1'-9" ALONG THE FACE OF RAIL FROM THE CENTERLINE OF BOLT TO ROADWAY SURFACE.
6. WHEN CURB AND GUTTER IS USED IN AN URBAN SETTING WITH W-BEAM GUARDRAIL, BOLT THE RAIL IN THE MIDDLE POST HOLE. ON STANDARD GUARDRAIL INSTALLATIONS THE TYPE SECTION 10 CURB IS USED EXCLUSIVELY.
7. THE WOODEN BLOCKOUTS SHALL BE TOE-NAILED TO THE WOODEN POST WITH 16d GALVANIZED NAILS TO RESTRICT BLOCK ROTATION.
8. GUARDRAIL POST SPACING SHALL BE 6'-3" C.T.C. UNLESS OTHERWISE SHOWN.
9. POST BOLTS FOR THE MODIFIED BLOCKOUT AND STEEL POST SHALL BE PLACED ON WEB HOLE ON THE APPROACHING TRAFFIC SIDE.
10. WHEN STEEL GUARDRAIL POSTS ARE INSTALLED, THE DATE (MONTH/YEAR) AND POST LENGTH SHALL BE STAMPED IN A CONSPICUOUS PLACE NEAR THE TOP AND BETWEEN THE WEBS OF THE POST. THE CHARACTERS SHALL BE 1/4" TO 3/8" IN HEIGHT.
11. WOODEN POSTS SHALL BE STAMPED OR SCRIBED WITH THE LENGTH (EITHER FEET OR INCHES IS ACCEPTABLE) OF THE POST ON THE TOP SURFACE. THE STAMPED LETTERING SHALL BE APPROXIMATELY 1 1/2" HIGH AND 1/4" DEEP. IF THE LETTERING IS DISTURBED DURING INSTALLATION IT SHALL BE RE-STAMPED.
12. ALL POST SPACING MEASUREMENTS ARE MADE ALONG THE (BACK OF RAIL) FROM CENTERLINE OF THE USED BOLT HOLE TO CENTERLINE OF THE USED BOLT HOLE.
13. NOT TO SCALE.

REVISIONS			
NO.	DATE	BY	DESCRIPTION

DESIGNED	
DESIGN CHECKED	
DETAILED	
DRAWING CHECKED	

SCALES SHOWN ARE FOR 11" X 17" PRINTS ONLY

CADD FILE NAME: g-2_1210.dgn

DRAWING DATE: JUNE, 1997

IDAHO TRANSPORTATION DEPARTMENT



PROJECT NO. _____

STANDARD DETAIL G-2

W-BEAM GUARDRAIL INSTALLATION ASSEMBLIES

English

COUNTY _____

KEY NUMBER _____

SHEET 1 OF 1

NOT APPROVED
PRELIMINARY
FOR CONSTRUCTION