

CONCRETE BARRIER OPTION

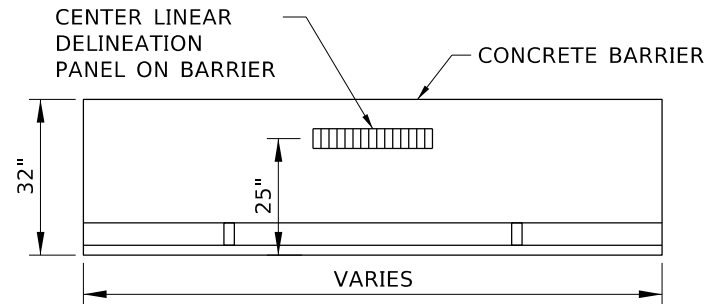

4" x 34" PANEL PLACEMENT ON CONCRETE BARRIER DETAIL

TABLE A

PANEL SPACING	
12.5' PRECAST CONCRETE BARRIER	INSTALL PANEL ON EVERY OTHER BARRIER
20' PRECAST CONCRETE BARRIER	INSTALL PANEL ON EVERY BARRIER
W-BEAM GUARDRAIL OR CAST IN-PLACE CONCRETE BARRIER	INSTALL PANEL EVERY 25' OF RAIL

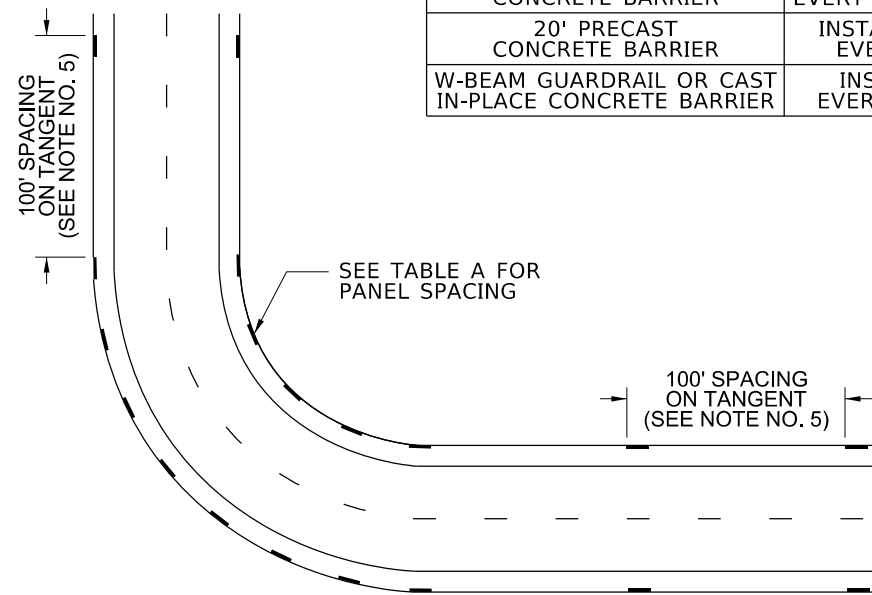

DESIGNER NOTE:
(delete before use)

ENHANCED DELINEATION MAY BE ADDED WHEN W-BEAM GUARDRAIL OR CONCRETE BARRIER IS PRESENT AND THE SPEED DIFFERENTIAL BETWEEN THE CURVE ADVISORY SPEED AND THE POSTED SPEED LIMIT IS 15 MPH OR GREATER.

THIS IS NOT A REPLACEMENT FOR STANDARD DELINEATION.

W-BEAM GUARDRAIL OPTIONS

WATERBORNE RETROREFLECTIVE STRIPING

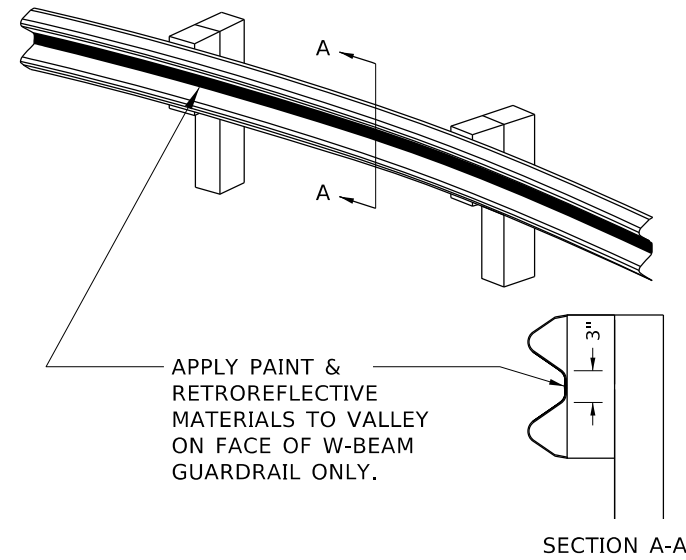

1.5" x 31" RETROREFLECTIVE PANELS

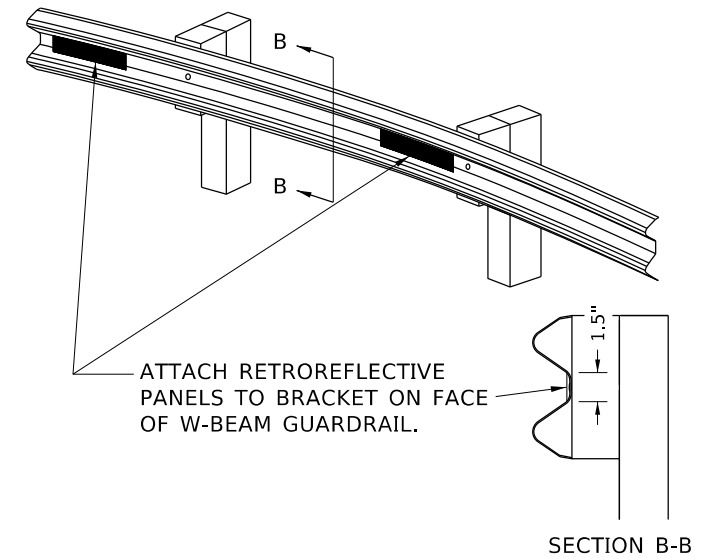

4" x 34" RETROREFLECTIVE PANELS

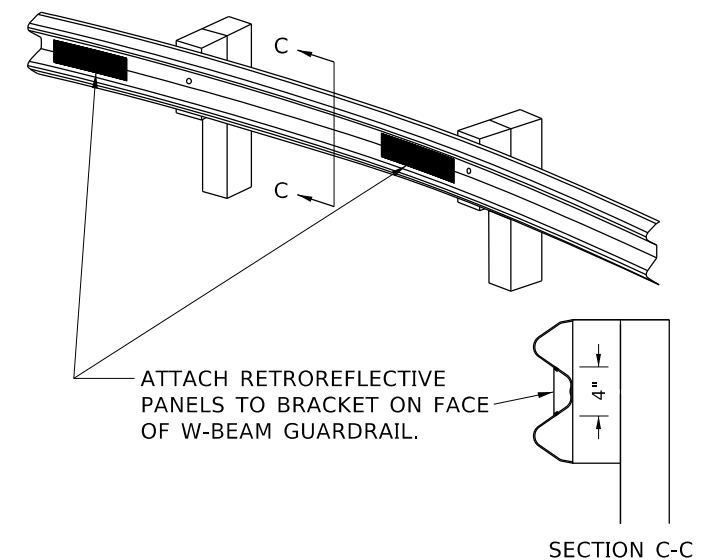

NOTES

1. USE PANELS AND WATERBORNE PAINT OF THE SAME COLOR AS THE CORRESPONDING EDGE LINE.
2. USE RETROREFLECTIVE SHEETING ON ALUMINUM SUBSTRATE MEETING 712.02 SPECIFICATIONS.
3. INSTALL RETROREFLECTIVE PANELS PER MANUFACTURER RECOMMENDATIONS USING NON-MECHANICAL METHODS.
4. DO NOT APPLY PANELS OVER SEAMS OR BOLT HEADS IN W-BEAM GUARDRAIL.
5. INSTALL A MINIMUM OF TWO PANELS ON TANGENT SECTIONS OF THE APPROACH CURVE.
6. DRAWING NOT TO SCALE.

REVISIONS			
NO.	DATE	BY	DESCRIPTION

DESIGNED	SCALES SHOWN ARE FOR 11" X 17" PRINTS ONLY
DESIGN CHECKED	
DETAILED	
DRAWING CHECKED	
CADD FILE NAME	DRAWING DATE:
DRAWING DATE:	

IDAHO TRANSPORTATION DEPARTMENT

YOUR Safety → YOUR Mobility → YOUR Economic Opportunity

PROJECT NO.

ENHANCED DELINEATION

ENGLISH
COUNTY
KEY NUMBER
SHEET OF

NOT APPROVED
PRELIMINARY
FOR CONSTRUCTION