

DRILL POLE CAP TO ACCEPT PHOTOELECTRIC CONTROL LOCKING TYPE RECEPTACLE. (SIGNAL POLES ONLY)

ALTERNATE LOCATION
POLE TOP MOUNTING FOR PHOTOELECTRIC CELL

ILLUMINATION POLES USE POLE TOP ADAPTER FOR THIS LOCATION

PHOTOELECTRIC CELL TWIST LOCK RECEPTACLE REQUIRED MOUNTED IN UPPER RIGHT SIDE OF CUSTOMER SECTION.

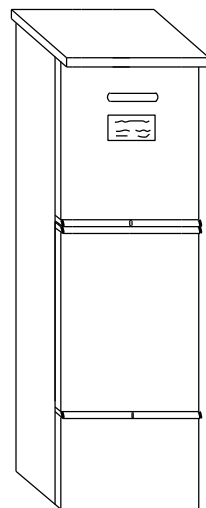

TYPICAL SERVICE PEDESTAL

SEE STANDARD DRAWING 1-7-A FOR FOUNDATION DETAIL

PEDESTAL FLANGE MOUNTING DETAIL

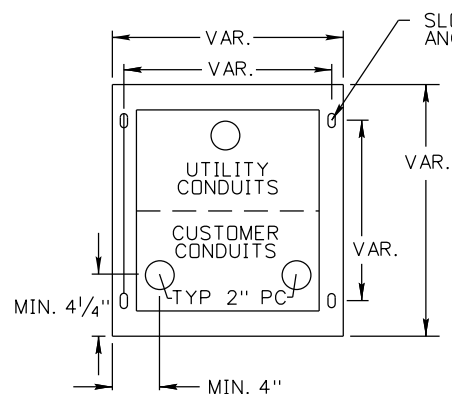

TO BE FURNISHED WITH 4 EACH 5/8" x 6" x 2"-13 NC ANCHOR BOLTS. NO SLEEVE REQUIRED.

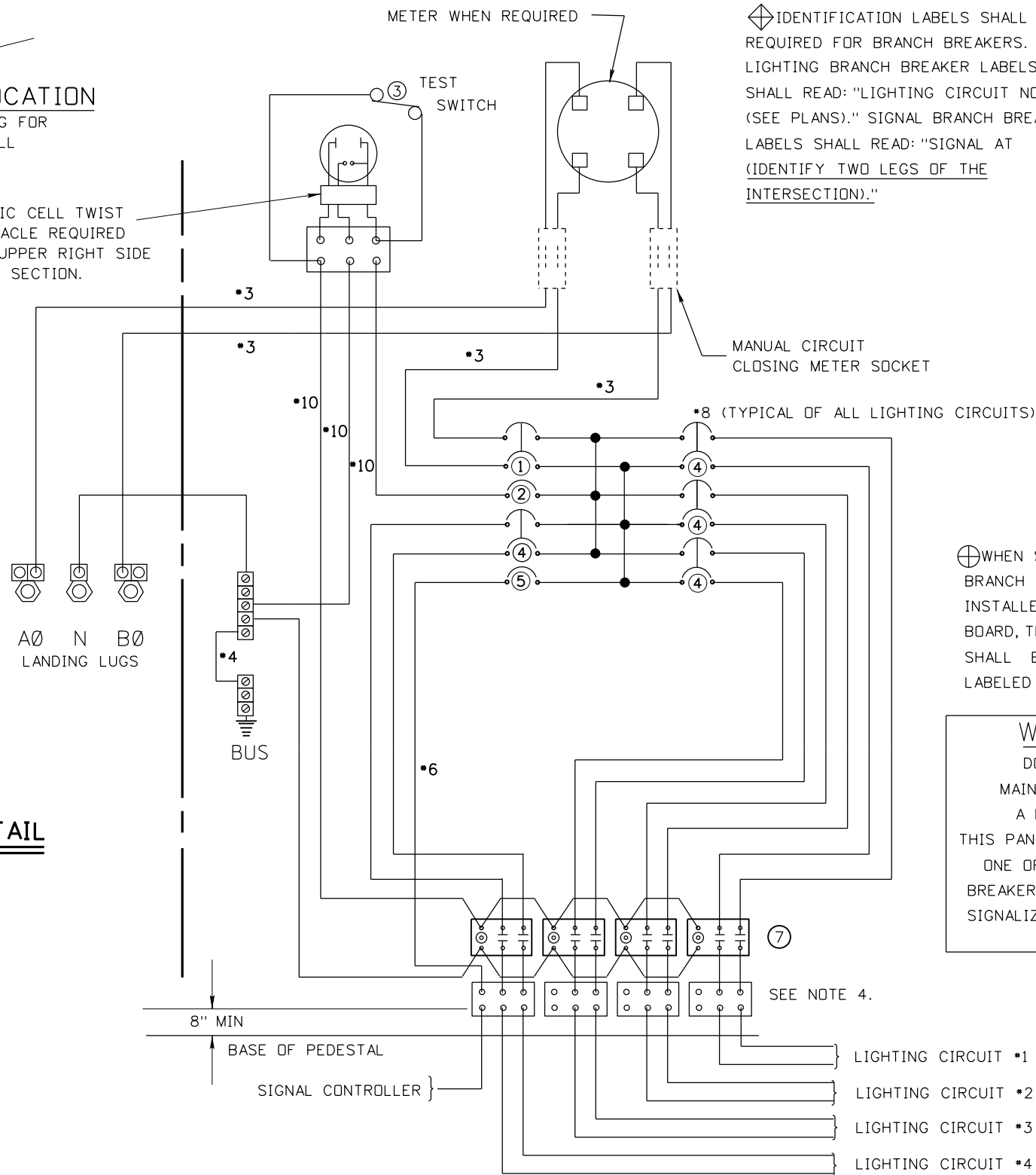

NOTE

IDENTIFICATION LABELS SHALL BE REQUIRED FOR BRANCH BREAKERS. LIGHTING BRANCH BREAKER LABELS SHALL READ: "LIGHTING CIRCUIT NO. (SEE PLANS)." SIGNAL BRANCH BREAKER LABELS SHALL READ: "SIGNAL AT (IDENTIFY TWO LEGS OF THE INTERSECTION)."

NOTE

WHEN SIGNAL & LIGHTING BRANCH BREAKERS ARE INSTALLED IN SAME PANEL BOARD, THE MAIN BREAKER SHALL BE PERMANENTLY LABELED AS FOLLOWS:

WARNING

DO NOT USE MAIN BREAKER AS A DISCONNECT THIS PANEL BOARD CONTAINS ONE OR MORE BRANCH BREAKERS CONTROLLING A SIGNALIZED INTERSECTION

SERVICE CABINET SCHEDULE

ITEM	CLASS "B"
① MAIN BREAKER	(SEE SCHEDULE)
② CONTROL BREAKER	1P-15A 120/240 VOLT
③ TEST SWITCH	SPST-15A 120/240 volt
④ LIGHTING BRANCH BREAKER	2P-120/240 VOLT (SEE DETAIL)
⑤ SIGNAL CONTROL BREAKER	1P-120/240 VOLT (SEE SCHEDULE)
⑥ NEMA 14-50R	120/240 VOLT
⑦ LIGHTING CONTACTOR	8P (ANY COMBINATION)
⑧ FLASHER CONTROL BREAKER	1P-120/240 VOLT (SEE SCHEDULE)
⑨ RECEPTACLE BRANCH BREAKER	2P-120/240 VOLT (SEE SCHEDULE)

BREAKER RATING SCHEDULE

CLASS "B"	
ITEM	NO. OF LIGHTING CIRCUITS
MAIN BREAKER	100 AMP 2P
LIGHTING BRANCH BREAKER	30 AMP 2P
SIGNAL CONTROL BREAKER	60 AMP 1P
LIGHTING CONTACTOR	30 AMP 4P
FLASHER CONTROL BREAKER	
SERVICE WIRE	NO. 3 THWN

NOTES:

- SERVICE CABINETS SHALL BE NEMA TYPE 3R. TO BE FURNISHED WITH A PADLOCK HASP.
- DEAD FRONT CONSTRUCTION IS REQUIRED ON ALL CABINETS.
- PLUG-IN TYPE BREAKERS SHALL BE USED ON "B" SERVICES. MAIN BREAKERS SHALL BE BOLT RETAINED.
- PRESSURE TYPE TERMINALS SHALL BE REQUIRED FOR *8 THROUGH *2 AWG. WIRE.
- ALL SERVICES SHALL BE U.L. LABELED FOR MAXIMUM 100 AMP BUS RATING, AND "APPROVED FOR SERVICE ENTRANCE EQUIPMENT."
- THE MAIN BREAKER LABEL SHALL BE MADE OF RED ON WHITE PLASTIC LAMINATE. THE BRANCH BREAKER LABELS SHALL BE MADE OF BLACK ON WHITE PLASTIC LAMINATE. THE LEGENDS SHALL BE ENGRAVED INTO THE STRIP SO AS TO PROVIDE WHITE LEGEND ON THE REQUIRED BACKGROUND. THE LABELS SHALL BE PERMANENTLY ATTACHED TO THE DEAD FRONT, NEXT TO THE CORRESPONDING BREAKERS.
- LIGHTING CONTACTORS, LIGHTING & SIGNAL BRANCH CIRCUIT BREAKERS TO BE FACTORY INSTALLED.
- BRANCH CIRCUIT WIRE AND PHOTOELECTRIC CONTROL TO BE SUPPLIED BY THE CONTRACTOR.
- ALL BUSSING TO BE 100 AMP RATED.
- WIRING SHALL BE THWN/MTW 600V 90°C RATED.

TYPE 1 SERVICE

REVISIONS			
NO.	DATE	BY	DESCRIPTION
1	09-07	NQB	REVISED TEXT AND BORDER SHEET
2	01-09	NQB	ADD VAR. TO FLANGE DETAIL

DESIGNED	SCALES SHOWN ARE FOR 11" X 17" PRINTS ONLY
DESIGN CHECKED	
DETAILED	CADD FILE NAME td01_0109.dgn
DRAWING CHECKED	DRAWING DATE: June, 1993

IDAHO TRANSPORTATION DEPARTMENT

PROJECT NO.	td-01
-------------	-------

SIGNALIZATION AND ILLUMINATION ELECTRICAL SERVICE PEDESTAL CONTROLLER FOUNDATION MOUNTED	
--	--

English
COUNTY
KEY NUMBER
SHEET OF

NOT APPROVED
PRELIMINARY
FOR CONSTRUCTION