

MANHOLE TOP  
SECTION C-C  
(SCALE 1/2" = 1")

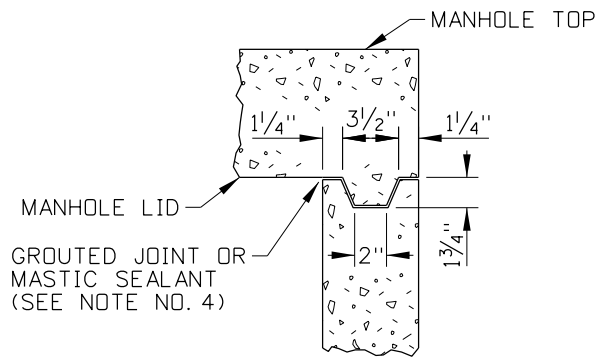

CONSTRUCTION JOINT DETAIL  
(NO SCALE)

NOTES

- CARE SHALL BE TAKEN TO AVOID PLACING MANHOLES IN WHEEL PATHS.
- MANHOLE TYPE B MAY BE EITHER PRECAST OR CAST-IN-PLACE. PRECAST MANHOLES SHALL MEET THE REQUIREMENTS OF ASTM C478. PRIOR APPROVAL OF THE SHOP DRAWING WILL BE REQUIRED ON PRECAST UNITS WITH FLOOR AND/OR PIPE OPENINGS.
- CAST-IN-PLACE MANHOLE TYPE B SHALL CONFORM TO SECTION 609 - MINOR STRUCTURES OF THE CURRENT ITD STANDARD SPECIFICATIONS FOR HIGHWAY CONSTRUCTION. CAST-IN-PLACE MANHOLES SHALL HAVE 6" WALLS AND MINIMUM 8" FLOORS. THE METAL REINFORCEMENT USED ON THE WALLS AND FLOORS SHALL BE NO. 4 BARS. ALL REINFORCEMENT SHALL HAVE A MINIMUM CONCRETE COVER OF 2" AND/OR 3" IF CAST AGAINST EARTH.
- ALL CONNECTIONS AND BROKEN AREAS SHALL BE GROUTED SMOOTH TO FORM A WATER TIGHT MANHOLE. MASTIC SEALANTS, GASKETS, USED ON PRECAST SECTION(S) CONSTRUCTION JOINT(S) SHALL CONFORM TO AASHTO AND ASTM REQUIREMENTS.
- BENDS IN THE MAIN STORM SEWER SHALL BE MADE BY FORMING CURVED CHANNELS WITHIN THE MANHOLE. THE INSIDE OF THE TOP LATERAL PIPES MAY NOT BE LOWER THAN THE INSIDE TOP OF MAIN SEWER PIPES. WHEN THE INVERT OF THE LATERAL PIPE FALLS BELOW THE 1" PER FOOT MINIMUM SLOPE LINE, THE CHANNEL SHALL BE FORMED FROM THE LATERAL PIPE TO THE MAIN SEWER.
- THE CONCRETE MANHOLE LIDS SHALL BE DESIGNED FOR AASHTO H-25 LIVE LOADS.
- WHEN MANHOLE DEPTH IS GREATER THAN 4'-0" INSTALL MANHOLE STEP(S), THE NORMAL STEP-TO-STEP SPACING IS 12" AND THE STEP PROTRUDES FROM THE MANHOLE WALL 4".
- USE OF A PLASTIC MANHOLE FRAME SUPPORT, I. E. WHIRLY-GIG OR COMPARABLE DEVICE IS AN ACCEPTABLE CONSTRUCTION OPTION (FOR FURTHER INFORMATION REFER TO STANDARD DRAWING 605-13).
- STANDARD DRAWING 605-13 SHALL ACCOMPANY THIS DRAWING.

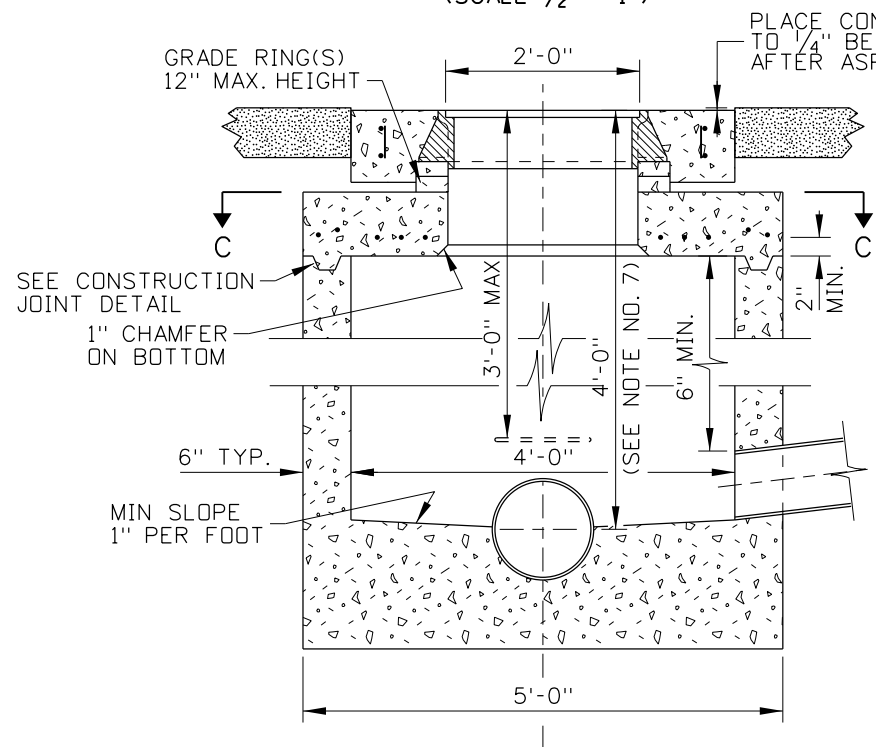

SECTION A-A  
(SCALE 1/2" = 1")

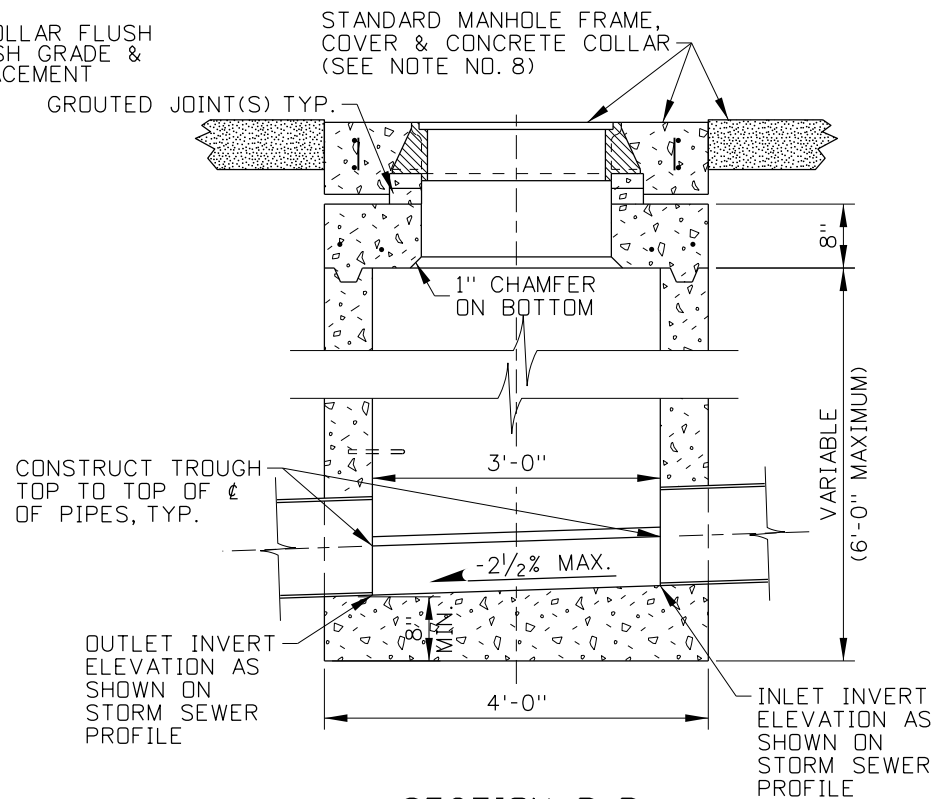

SECTION B-B  
(SCALE 1/2" = 1")

REVISIONS							
NO.	DATE	BY	NO.	DATE	BY	NO.	DATE
1	03-64		6	09-04	MSM		
2	04-71		7	05-07	MSM		
3	05-71						
4	12-92	MSM					
5	11-01	MSM					

SCALES SHOWN ARE FOR 11" X 17" PRINTS ONLY  
CADD FILE NAME: 605-11\_0507.dgn  
DRAWING DATE: JUNE, 1961

**IDAHO TRANSPORTATION DEPARTMENT**



BOISE IDAHO

ORIGINAL SIGNED BY: LOREN THOMAS  
ASSISTANT CHIEF ENGINEER (DEVELOPMENT)  
ORIGINAL SIGNED BY: STEVEN HUTCHINSON  
CHIEF ENGINEER

STANDARD DRAWING  
**MANHOLE TYPE B**  
REQUIRES STD. DWG. 605-13

ORIGINAL STORED AT: ITD, Headquarters 3311 West State Boise, Idaho

**English**  
STANDARD DRAWING NO. **605-11**  
SHEET 1 OF 1

