

PRECAST JOINT DETAIL
(NO SCALE)

SUB-NOTES
 * a MANHOLE TYPE C (48" DIA. SECTION),
 MANHOLE TYPE D (60" DIA. SECTION)
 * b 24" MAX. PIPE DIA. W/48" DIA. SECTION
 36" MAX. PIPE W/60" DIA. SECTION

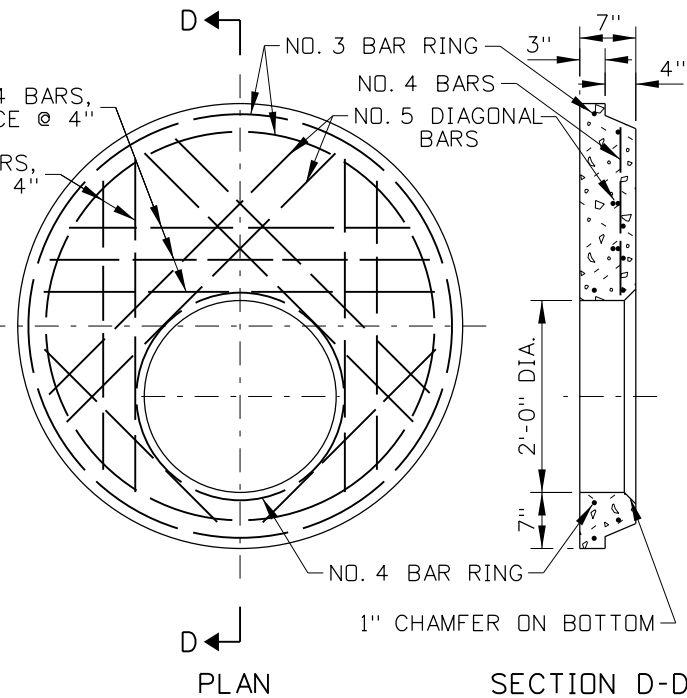

48" DIA. FLAT LID
(SCALE 1/2" = 1")

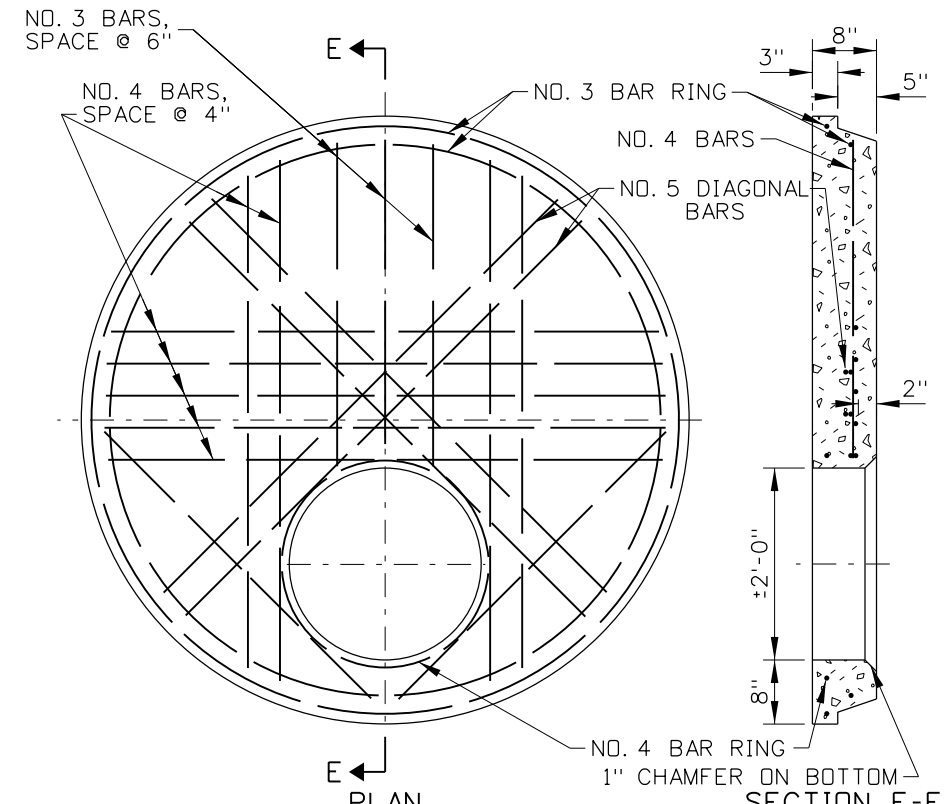

60" DIA. FLAT LID
(SCALE 1/2" = 1")

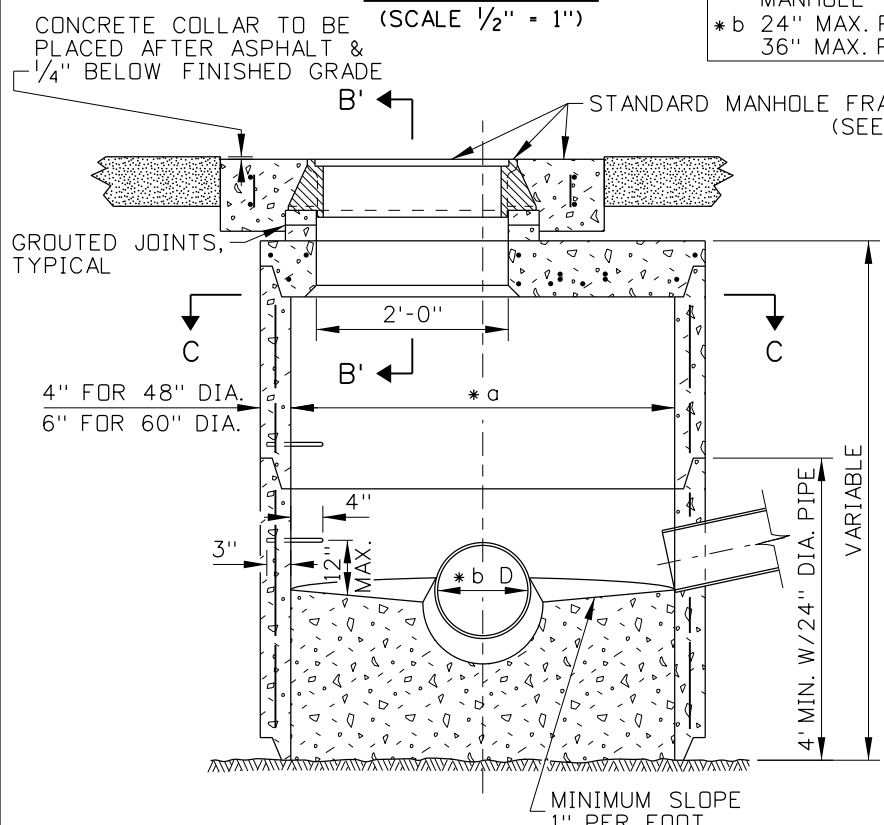

SECTION A-A
(SCALE 1/2" = 1")

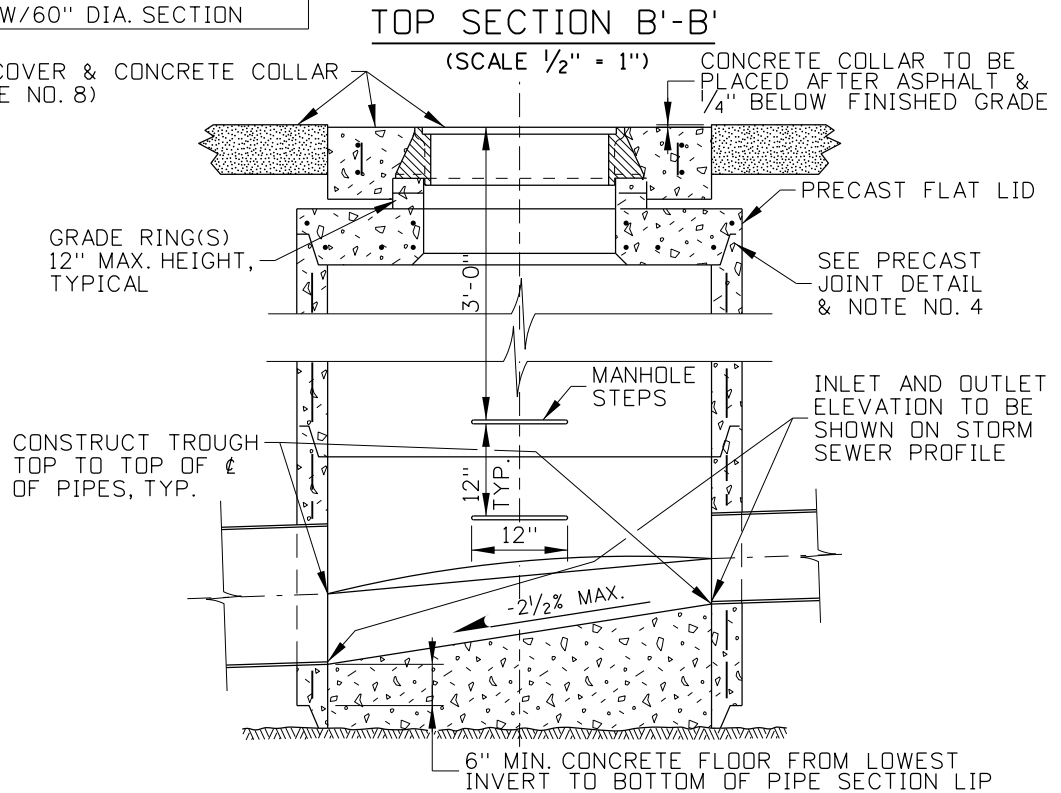

BOTTOM SECTION B-B
(SCALE 1/2" = 1")

NOTES

- CARE SHALL BE TAKEN TO AVOID PLACING MANHOLES IN WHEEL PATHS.
- MANHOLES TYPE C & D MAY BE EITHER PRECAST OR CAST-IN-PLACE. PRECAST MANHOLES SHALL MEET THE REQUIREMENTS OF ASTM C478. PRIOR APPROVAL OF THE SHOP DRAWING WILL BE REQUIRED ON PRECAST UNITS WITH FLOOR AND/OR PIPE OPENINGS.
- CAST-IN-PLACE MANHOLES TYPE C & D SHALL CONFORM TO SECTION 609 - MINOR STRUCTURES OF THE CURRENT "ITD STANDARD SPECIFICATIONS FOR HIGHWAY CONSTRUCTION". CAST-IN-PLACE MANHOLES SHALL HAVE 6" WALLS AND MINIMUM 8" FLOORS. THE METAL REINFORCEMENT USED ON THE WALLS AND FLOORS SHALL BE NO. 4 BARS. ALL REINFORCEMENT SHALL HAVE A MINIMUM CONCRETE COVER OF 2" AND/OR 3" IF CAST AGAINST EARTH.
- ALL CONNECTIONS AND BROKEN AREAS SHALL BE GROUTED SMOOTH TO FORM A WATER TIGHT MANHOLE. MASTIC SEALANTS, GASKETS, AND O-RINGS USED ON PRECAST SECTION(S) CONSTRUCTION JOINT(S) SHALL CONFORM TO AASHTO AND ASTM REQUIREMENTS.
- BENDS IN THE MAIN STORM SEWER SHALL BE MADE BY FORMING CURVED CHANNELS WITHIN THE MANHOLE. THE INSIDE OF THE TOP LATERAL PIPES MAY NOT BE LOWER THAN THE INSIDE TOP OF MAIN SEWER PIPES. WHEN THE INVERT OF THE LATERAL PIPE FALLS BELOW THE 1" PER FOOT MINIMUM SLOPE LINE, THE CHANNEL SHALL BE FORMED FROM THE LATERAL PIPE TO THE MAIN SEWER.
- THE CONCRETE MANHOLE LIDS SHALL BE DESIGNED FOR AASHTO H-25 LIVE LOADS.
- WHEN MANHOLE STEPS ARE REQUIRED AN ECCENTRIC CONE SECTION SHALL BE USED. PLASTIC COATED MANHOLE STEPS SHALL BE PLACED IN MANHOLES GREATER THAN 4' IN DEPTH. MANHOLE STEPS SHALL CONFORM TO IDAHO STANDARDS FOR PUBLIC WORKS CONSTRUCTION, STANDARD DRAWING SD-509 AND SECTION 504.06 PLASTIC COATED MANHOLE STEPS.
- USE OF A PLASTIC MANHOLE FRAME SUPPORT, I.E. WHIRLY-GIG OR COMPARABLE DEVICE, IS AN ACCEPTABLE CONSTRUCTION OPTION (FOR FURTHER INFORMATION REFER TO STANDARD DRAWING 605-13).

ORIGINAL STORED AT: ITD, Headquarters 3311 West State Boise, Idaho

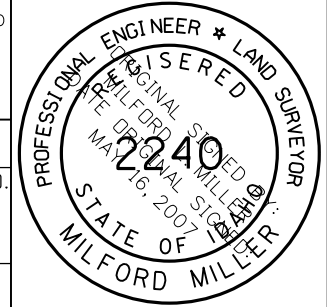

REVISIONS							
NO.	DATE	BY	NO.	DATE	BY	NO.	DATE
1	12-92	MSM					
2	11-01	MSM					
3	12-04	MSM					
4	05-07	MSM					

SCALES SHOWN ARE FOR 11" X 17" PRINTS ONLY
 CADD FILE NAME: 605-12_0507.dgn
 DRAWING DATE: MAY, 1981

IDAHO TRANSPORTATION DEPARTMENT
 BOISE IDAHO

ORIGINAL SIGNED BY: LOREN THOMAS
 ASSISTANT CHIEF ENGINEER (DEVELOPMENT)
 ORIGINAL SIGNED BY: STEVEN HUTCHINSON
 CHIEF ENGINEER

STANDARD DRAWING
MANHOLE TYPES C & D
 REQUIRES STD. DWG. 605-13

English
 STANDARD DRAWING NO.
605-12
 SHEET 1 OF 1