

BAR LIST					
MARK	LOCATION	SIZE	TOTAL LENGTH	NO.	SKETCH
A1	FLOOR & WALLS	4	5'-1"	2	5'-1"
A2	WALLS	4	15'-1"	3	5'-0" 5'-0" 1" MIN. OVERLAP
* A3	FRONT WALL	4	3'-7"	4	3'-7"
* A4	BACK WALL	4	4'-1"	4	4'-1"
A5	GRATE DOWEL	4	7"	10	2 L 5"
A6	WALL	4	2'-2"	2	2'-2"
A7	GUTTER & SIDE WALLS	4	2'-9"	4	5° 2'-0" 9"
A8	CURB & BACK WALL	4	3'-3"	2	2'-0" 1'-3"
113.75 L.F. AT 0.668 LBS/FT. = 76.00 LBS					

* (SEE NOTE NO. 7)

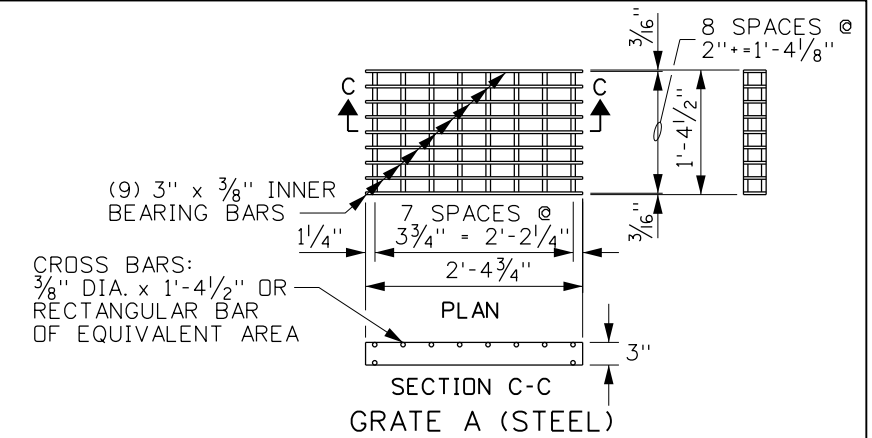

(WEIGHT : APPROXIMATELY 88 LBS., SEE NOTE 9)

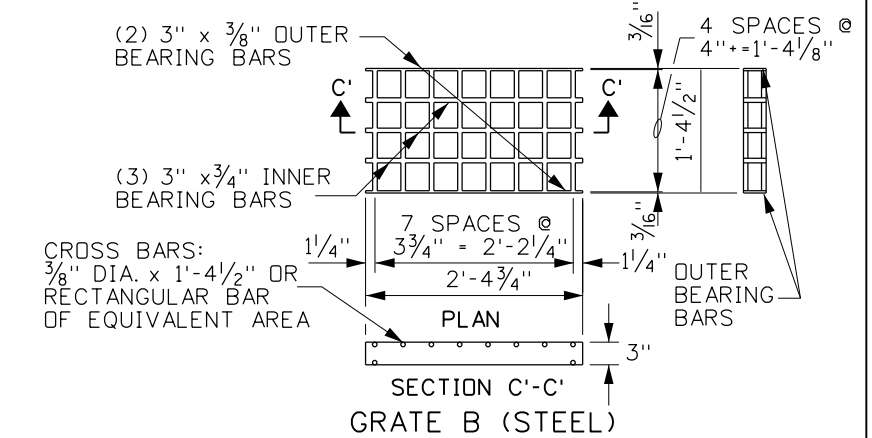

(WEIGHT : APPROXIMATELY 79 LBS., SEE NOTE 9)

NOTES

- CATCH BASINS MAY EITHER BE PRECAST OR CAST-IN-PLACE. PRECAST UNITS SHALL MEET THE REQUIREMENTS OF ASTM C913. PRIOR APPROVAL OF THE SHOP DRAWING WILL BE REQUIRED ON MODIFIED UNITS.
- CAST-IN-PLACE CATCH BASINS SHALL CONFORM TO SECTION 609 - MINOR STRUCTURES OF THE CURRENT ITD STANDARD SPECIFICATIONS FOR HIGHWAY CONSTRUCTION.
- A 1" SIDE DRAFT IS ALLOWED FOR FORM REMOVAL.
- THE GRADE LINE OF THE TOP INSIDE OF ANY PIPE SHALL ENTER AT A POINT NO LOWER THAN THE TOP INSIDE OF THE OUTLET PIPE.
- PIPES CAN ENTER OR LEAVE THE BOX IN ANY DIRECTION. ALL CONNECTIONS AND BROKEN AREAS SHALL BE GROUTED SMOOTH.
- STEEL ANGLES SHALL BE SET SO THAT EACH BEARING BAR OF PREFABRICATED GRATE SHALL HAVE FULL BEARING ON BOTH ENDS. THE FINISHED TOP OF CONCRETE SHALL BE EVEN WITH THE ANGLE/GRATE SURFACE. THE STRUCTURAL STEEL NEED NOT BE PAINTED BUT SHALL MEET THE REQUIREMENTS OF ASTM A 36.
- ALL METAL REINFORCEMENT USED SHALL BE NO. 4 BARS. THE METAL REINFORCEMENT SHALL BE SMOOTH CUT TO ACCOMMODATE PIPES. VERTICAL BARS NEED TO BE LENGTHENED FOR CATCH BASINS DEEPER THAN 4'-6".
- GRATE B WILL BE USED ONLY WHEN SPECIFIED.
- GRAY IRON CAST TO THE DIMENSIONS GIVEN FOR THE STEEL GRATES MAY BE USED. THE CASTINGS SHALL CONFORM TO AASHTO M306 CLASS 35B GRAY IRON CASTINGS.
- CATCH BASIN GRATES MAY EITHER BE RESISTANCE WELDED OR ARC WELDED. IN EITHER CASE THE GRATE SHALL BE TRUE AND FLUSH.
- NOT TO SCALE.

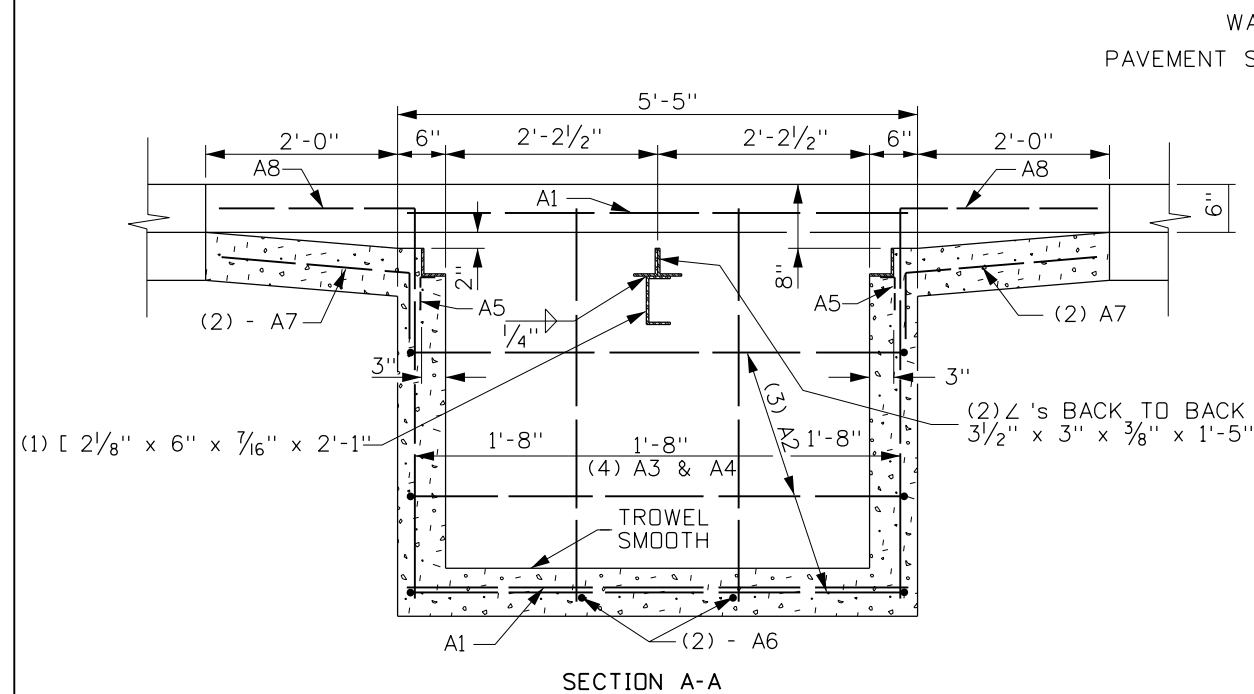

CATCH BASIN - DETAILS

REVISIONS							
NO.	DATE	BY	NO.	DATE	BY	NO.	DATE
1	10-80		6	03-01	MSM		
2	04-82		7	12-04	MSM		
3	03-84		8	11-08	JRV		
4	01-89						
5	12-94	MSM					

SCALES SHOWN ARE FOR 11" X 17" PRINTS ONLY
 CADD FILE NAME: 605-23_1108.dgn
 DRAWING DATE: OCTOBER, 1980

IDAHO TRANSPORTATION DEPARTMENT

BOISE IDAHO

ORIGINAL SIGNED BY: LOREN THOMAS
 ASSISTANT CHIEF ENGINEER (DEVELOPMENT)

ORIGINAL SIGNED BY: TOM COLE
 CHIEF ENGINEER

STANDARD DRAWING
CATCH BASIN TYPE 6

ORIGINAL STORED AT: ITD, Headquarters 3311 West State Boise, Idaho

English

STANDARD DRAWING NO.
605-23

SHEET 1 OF 1

ORIGINAL SIGNED BY:
 DATE: TED E. MASON
 NOVEMBER 3, 2008