

* a ADJUST TO FIT FIELD CONDITIONS
METAL REINFORCEMENT NO. 4 BARS
PLAN

* b TABLE OF DIMENSIONS

D/D'	A/A'	B MIN.	F/F'	G	BARS (E.A.)	T
18"	3'-4"	3'-0"	2'-3"	3"	1	1/4"
24"	4'-0"	3'-7"	2'-11"	3 3/8"	2	1/4"
30"	4'-6"	4'-3"	3'-5"	3 3/8"	3	5/16"
36"	5'-0"	4'-9"	3'-11"	3 3/8"	3	3/8"
48"	6'-0"	5'-2"	4'-11"	3 3/8"	4	1/2"

* b SEE NOTE NO. 5

1" DIA. BARS SHALL BE INSERTED THROUGH 1/16" HOLES DRILLED OR PUNCHED THROUGH 1/8" OF FLAT BARS.

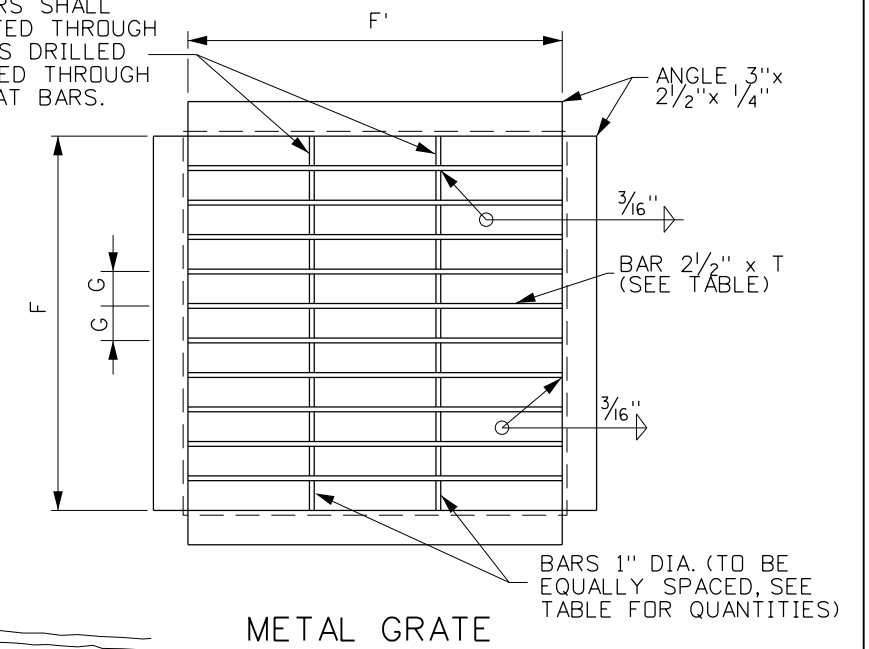

METAL GRATE

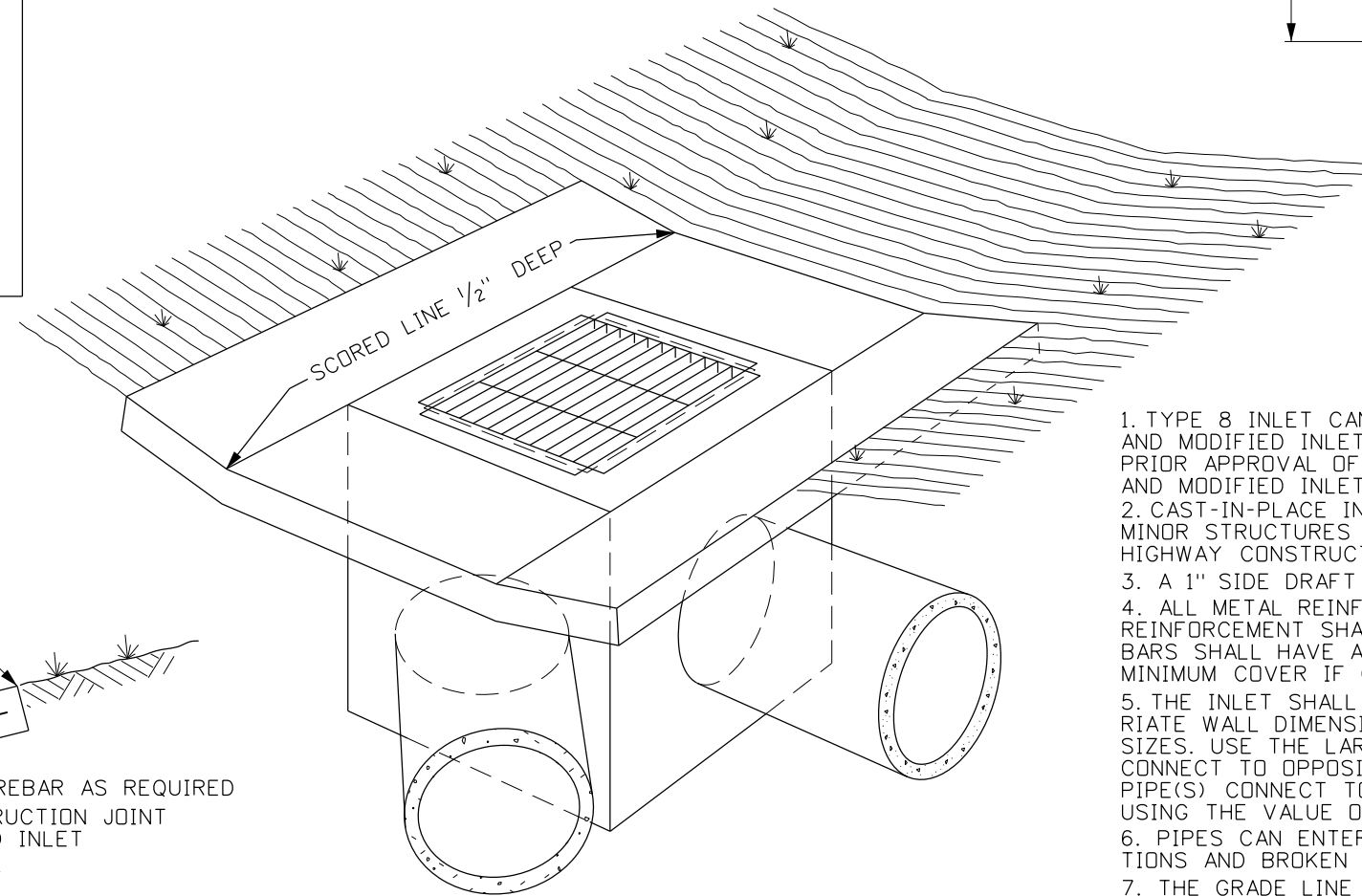

PERSPECTIVE VIEW

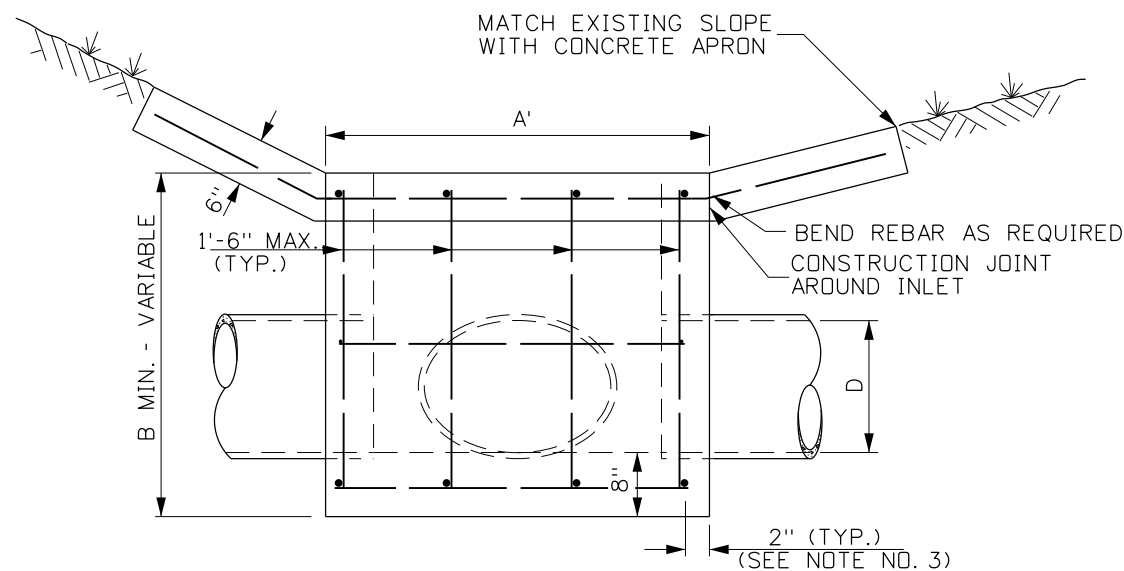

ELEVATION

INLET - DETAILS

NOTES

1. TYPE 8 INLET CAN BE EITHER PRECAST OR CAST-IN-PLACE. PRECAST AND MODIFIED INLETS SHALL MEET THE REQUIREMENTS OF ASTM C913. PRIOR APPROVAL OF SHOP DRAWINGS IS REQUIRED FOR USE OF PRECAST AND MODIFIED INLETS. THE APRON MUST BE CAST-IN-PLACE.
2. CAST-IN-PLACE INLET TYPE 8 SHALL CONFORM TO SECTION 609 - MINOR STRUCTURES OF THE CURRENT ITD STANDARD SPECIFICATIONS FOR HIGHWAY CONSTRUCTION.
3. A 1" SIDE DRAFT IS ALLOWED FOR FORM REMOVAL.
4. ALL METAL REINFORCEMENT USED SHALL BE NO. 4 BARS. THE METAL REINFORCEMENT SHALL BE SMOOTH CUT TO ACCOMMODATE PIPES. ALL BARS SHALL HAVE A MINIMUM CONCRETE COVER OF 2" AND/OR 3" MINIMUM COVER IF CAST AGAINST EARTH.
5. THE INLET SHALL BE CONSTRUCTED RECTANGULAR USING THE APPROPRIATE WALL DIMENSIONS (A & A') DETERMINED BY THE CONNECTING PIPE SIZES. USE THE LARGER WALL DIMENSION IF TWO DIFFERENT PIPE SIZES CONNECT TO OPPOSITE WALLS. USE THE MINIMUM WALL DIMENSION IF NO PIPE(S) CONNECT TO OPPOSITE WALLS. SELECT THE DEPTH (B MIN.) BY USING THE VALUE OF THE INLET'S LARGEST CONNECTING PIPE.
6. PIPES CAN ENTER OR LEAVE THE BOX IN ANY DIRECTION. ALL CONNECTIONS AND BROKEN AREAS SHALL BE GROUTED SMOOTH.
7. THE GRADE LINE OF THE TOP INSIDE OF ANY INLET PIPE SHALL BE AT A POINT NO LOWER THAN THE TOP INSIDE OF THE OUTLET PIPE.
8. ONLY COMBINATIONS OF THE DIMENSIONS SHOWN ON THE TABLE SHALL BE USED TO CONSTRUCT A TYPE 8 INLET.
9. THE METAL FOR THE GRATE SHALL MEET THE REQUIREMENTS OF ASTM A36. THE METAL GRATE NEED NOT BE PAINTED OR GALVANIZED.
10. WELDING OF THE METAL GRATE SHALL MEET THE REQUIREMENTS OF THE AMERICAN WELDING SOCIETY D1.1.
11. GRAY IRON CAST TO THE DIMENSIONS GIVEN FOR THE STEEL GRATES MAY BE USED. THE CASTINGS SHALL CONFORM TO AASHTO M306 CLASS 35B GRAY IRON CASTINGS.
12. NOT TO SCALE.

REVISIONS

NO.	DATE	BY	NO.	DATE	BY	NO.	DATE	BY
1	10-80		6	11-08	JRV			
2	12-92	MSM						
3	1-97	MSM						
4	3-01	MSM						
5	12-04	MSM						

SCALES SHOWN ARE FOR 11" X 17" PRINTS ONLY
CADD FILE NAME: 605-25_1108.dgn
DRAWING DATE: AUGUST, 1972

IDAHO TRANSPORTATION DEPARTMENT
BOISE IDAHO

ORIGINAL SIGNED BY: LOREN THOMAS
ASSISTANT CHIEF ENGINEER (DEVELOPMENT)
ORIGINAL SIGNED BY: TOM COLE
CHIEF ENGINEER

STANDARD DRAWING
INLET TYPE 8

ORIGINAL STORED AT: ITD, Headquarters 3311 West State Boise, Idaho
English
STANDARD DRAWING NO. 605-25
SHEET 1 OF 1

PROFESSIONAL ENGINEER
REGISTERED
NOVEMBER 3, 2004
STATE OF IDAHO
TED E. MASON