

| BAR LIST | | | | | |
|----------|---|------|------------|-----|---------------------|
| MARK | LOCATION | SIZE | BAR LENGTH | NO. | SKETCH |
| B1 | VERT. IN WALLS & FLOOR (ADD LENGTH AS NEEDED) | 4 | VARIES | 6 | 3'-8" MIN. 2'-7" |
| B2 | VERT. IN WALLS & FLOOR (ADD LENGTH AS NEEDED) | 4 | VARIES | 4 | 3'-8" MIN. 7'-1" |
| B3 | WALLS (AS NEEDED) | 4 | 7'-2" | * | 7'-2" |
| B4 | WALLS (AS NEEDED) | 4 | 2'-8" | * | 2'-8" |
| B5 | WELDED TO: L's 3 1/2" x 3" x 3/8" IN SIDE WALLS | 4 | 7" | 6 | 12" |

* (4) MIN., ADD BARS AS NEEDED

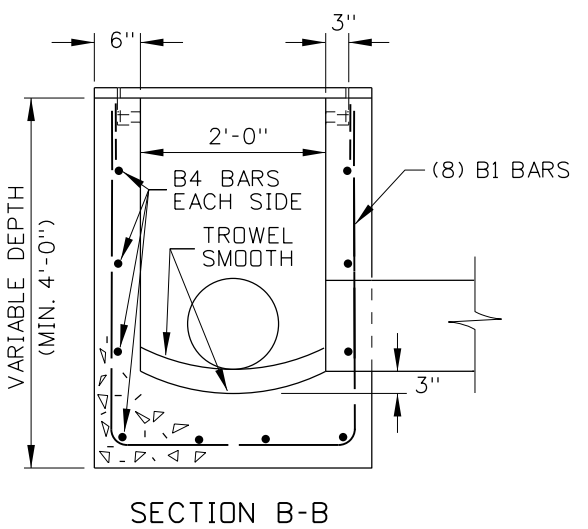

- NOTES**
1. INLET MEDIAN DRAIN MAY BE EITHER PRECAST OR CAST-IN-PLACE. PRECAST UNITS SHALL MEET THE REQUIREMENTS OF ASTM C913. PRIOR APPROVAL OF THE SHOP DRAWING WILL BE REQUIRED ON PRECAST UNITS.
 2. A 1" SIDE DRAFT IS ALLOWED FOR FORM REMOVAL.
 3. CAST-IN-PLACE INLET MEDIAN DRAINS SHALL CONFORM TO SECTION 609 - MINOR STRUCTURES OF THE CURRENT ITD STANDARD SPECIFICATIONS FOR HIGHWAY CONSTRUCTION.
 4. THE GRADE LINE OF THE TOP INSIDE OF ANY PIPE SHALL ENTER AT A POINT NO LOWER THAN THE TOP INSIDE OF THE OUTLET PIPE.
 5. PIPES CAN ENTER OR LEAVE THE BOX IN ANY DIRECTION. ALL CONNECTIONS AND BROKEN AREAS SHALL BE GROUTED SMOOTH.
 6. STEEL ANGLES SHALL BE SET SO THAT EACH BEARING BAR OF PREFABRICATED GRATE SHALL HAVE FULL BEARING ON BOTH ENDS. THE FINISHED TOP OF CONCRETE SHALL BE EVEN WITH THE ANGLE/GRATE SURFACE. THE STRUCTURAL STEEL NEED NOT BE PAINTED BUT SHALL MEET THE REQUIREMENTS OF ASTM A36.
 7. ALL METAL REINFORCEMENT SHALL BE NO. 4 BARS. METAL REINFORCEMENT SHALL BE SMOOTH CUT TO FIT AROUND PIPES. VERTICAL BARS NEED TO LENGTHENED TO ACCOMMODATE INLET DEPTH.
 8. THE (10) FLAT BARS AT THE 45° ANGLE MUST BE POINTED DOWN AND IN THE DIRECTION OF THE FLOW.
 9. GRAY IRON CAST TO THE DIMENSIONS GIVEN FOR THE STEEL GRATES MAY BE USED. THE CASTINGS SHALL CONFORM TO AASHTO M306 CLASS 35B GRAY IRON CASTINGS.
 10. NOT TO SCALE.

INLET MEDIAN DRAIN - DETAILS

| REVISIONS | | | | | | | |
|-----------|-------|-----|-----|------|----|-----|------|
| NO. | DATE | BY | NO. | DATE | BY | NO. | DATE |
| 1 | 05-07 | MSM | | | | | |
| 2 | 09-10 | PLR | | | | | |

SCALES SHOWN ARE FOR 11" X 17" PRINTS ONLY
 CADD FILE NAME: 605-26_1010.dgn
 DRAWING DATE: DECEMBER, 2004

IDAHO TRANSPORTATION DEPARTMENT

BOISE IDAHO

ORIGINAL SIGNED BY: LOREN THOMAS
 ASSISTANT CHIEF ENGINEER (DEVELOPMENT)
 ORIGINAL SIGNED BY: TOM COLE
 CHIEF ENGINEER

STANDARD DRAWING
INLET MEDIAN DRAIN TYPE 9

ORIGINAL STORED AT: ITD, Headquarters 3311 West State Boise, Idaho

English

STANDARD DRAWING NO. **605-26**

SHEET 1 OF 1

