

- NOTES**
1. SEDIMENT CONTROL BOXES CAN BE EITHER PRECAST OR CAST-IN-PLACE. DETAILED DRAWING OF SEDIMENT CONTROL BOX SHALL BE SUBMITTED AND APPROVED BY THE ENGINEER PRIOR TO CONSTRUCTION.
 2. CAST-IN-PLACE BOXES SHALL CONFORM TO SECTION 609 - MINOR STRUCTURES OF THE CURRENT ITD STANDARD SPECIFICATIONS FOR HIGHWAY CONSTRUCTION.
 3. DESIGN LOAD SHALL MEET AASHTO H-25 HIGHWAY LOADING AND CLASS 4000 PSI CONCRETE.
 4. ALL REINFORCING STEEL SHALL BE GRADE 60.
 5. THE FINISHED TOP OF CONCRETE SHALL BE EVEN WITH THE GRATE SURFACE.
 6. THE CATCH BASIN MANHOLE FRAME AND COVER SHALL BE A FLUSH MOUNT TYPE WITH A FRAME NO DEEPER THAN 4". THE FLUSH MOUNT MANHOLE IS NOT PERMITTED FOR VEHICULAR TRAFFIC.
 7. TANK CAPACITY IS APPROXIMATELY 750 GALLONS OR 100 CUBIC FEET.
 8. DESIGN MAY BE REVERSED FOR BEST APPLICATION WITH MANHOLE AND CATCH BASIN OPENINGS IN OPPOSITE DIRECTIONS AND BAFFLE WALLS REVERSED.
 9. GRAY IRON CAST TO THE DIMENSIONS GIVEN FOR THE STEEL GRATES MAY BE USED. THE CASTINGS SHALL CONFORM TO AASHTO M306 CLASS 35B GRAY IRON CASTINGS.
 10. INLET/CATCH BASIN GRATES MAY EITHER BE RESISTANCE WELED OR ARC WELDED. IN EITHER CASE THE GRATE SHALL BE TRUE AND FLUSH.
 11. NOT TO SCALE.

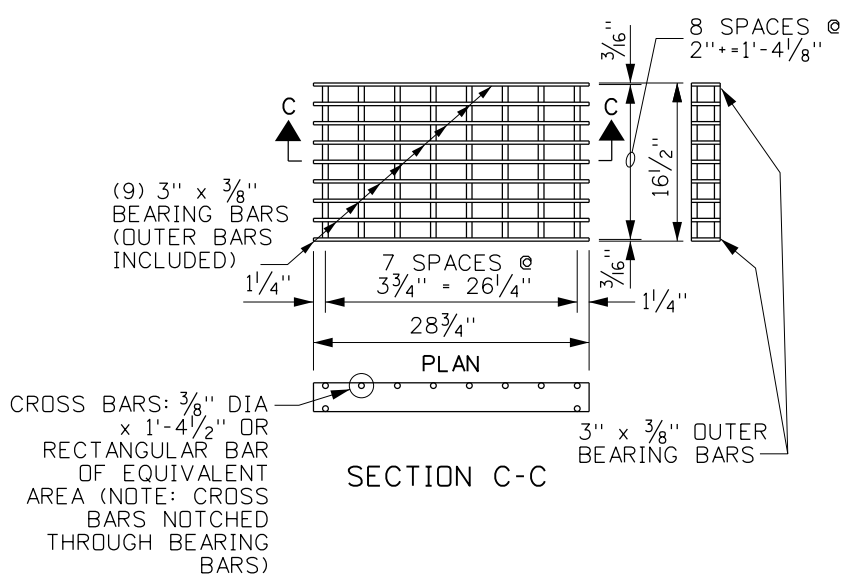

STEEL GRATE
(WEIGHT: APPROXIMATELY 88 LBS., SEE NOTE 9 & 10)

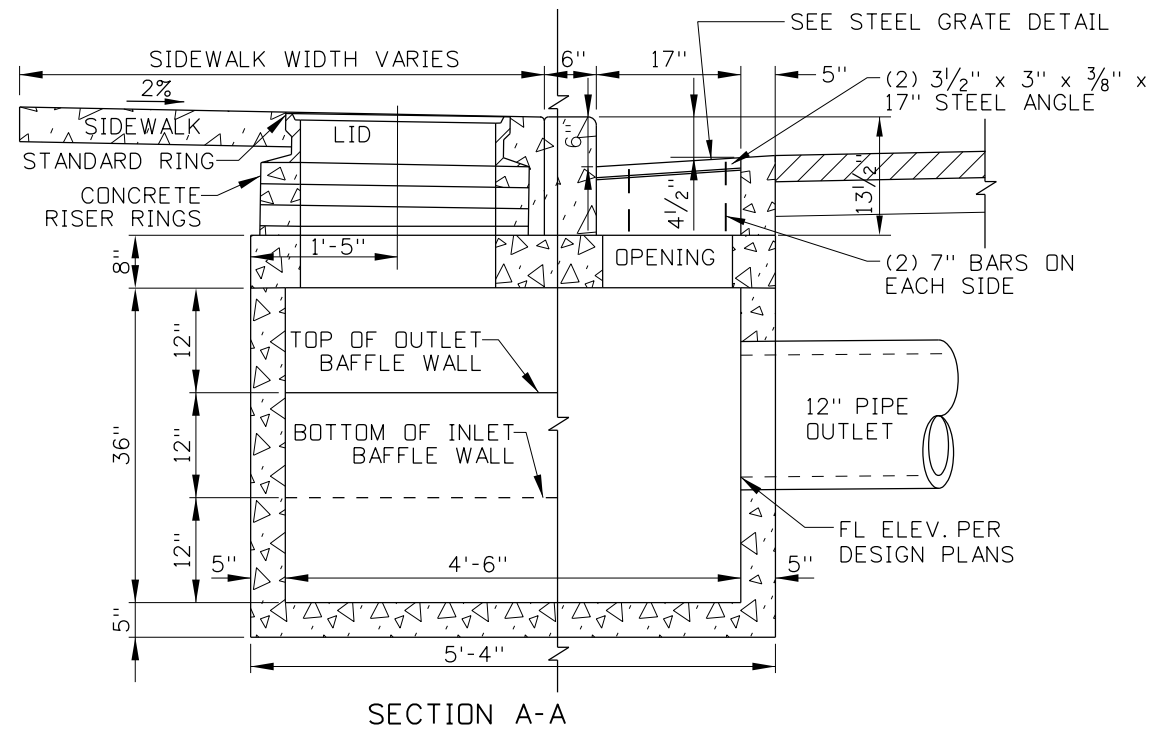

REVISIONS								
NO.	DATE	BY	NO.	DATE	BY	NO.	DATE	BY
1	02-96	MSM						
2	10-11	KEH						

SCALES SHOWN ARE FOR 11" X 17" PRINTS ONLY

CADD FILE NAME: 605-30_1011.dgn

DRAWING DATE: JANUARY, 1994

IDAHO TRANSPORTATION DEPARTMENT

BOISE IDAHO

ORIGINAL SIGNED BY: LOREN THOMAS
HIGHWAYS PROGRAM OVERSIGHT ENGINEER

ORIGINAL SIGNED BY: TOM COLE
CHIEF ENGINEER

STANDARD DRAWING

SEDIMENT CONTROL CATCH BASIN

ORIGINAL STORED AT: ITD, Headquarters 3311 West State Boise, Idaho

English

STANDARD DRAWING NO. **605-30**

SHEET 1 OF 1

ORIGINAL SIGNED BY: KARISSA HARDY
DATE ORIGINAL SIGNED: OCTOBER 3, 2011