

* a ADJUST WALL ENDS TO FILL SLOPE. WHEN CULVERT IS SKEWED TO EMBANKMENT, SLOPE THE ANGLE OF THE HEADWALL TO MEET THE HIGH SIDE.

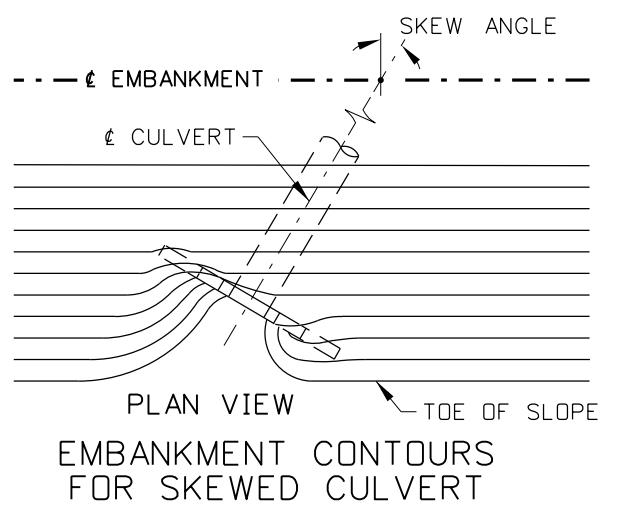

DIMENSION TABLE						
DIA. (INCHES)	C (INCHES)	V (INCHES)	W (INCHES)	X (INCHES)	Y (INCHES)	Z (INCHES)
18	24	36	4	8	5	8
24	24	48	5	9	6	9
30	24	60	6	9	8	9
36	24	54	11	10	9	10
42	24	63	13	10	11	10
48	24	72	14	10	12	10
54	24	81	15	11	14	11
60	24	90	16	11	15	11
72	36	108	19	11	18	11
84	36	126	21	11	21	11
96	36	144	24	12	24	12
108	36	162	27	14	27	14
120	36	180	30	15	30	15
144	36	216	36	18	36	18
180	36	270	45	23	45	23

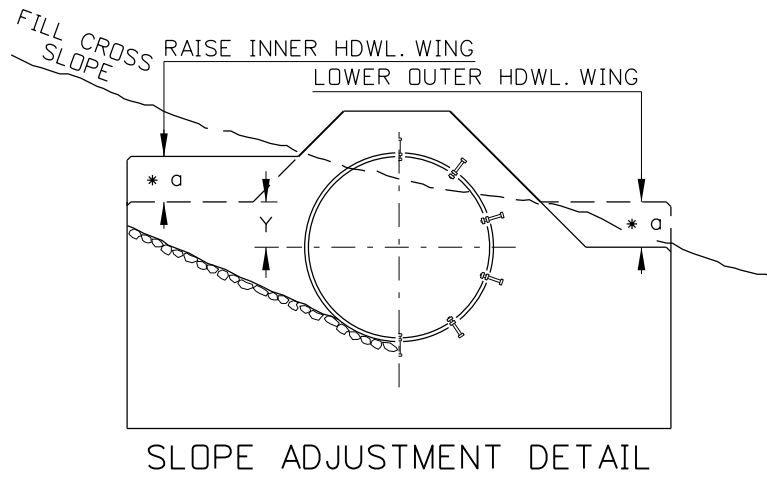
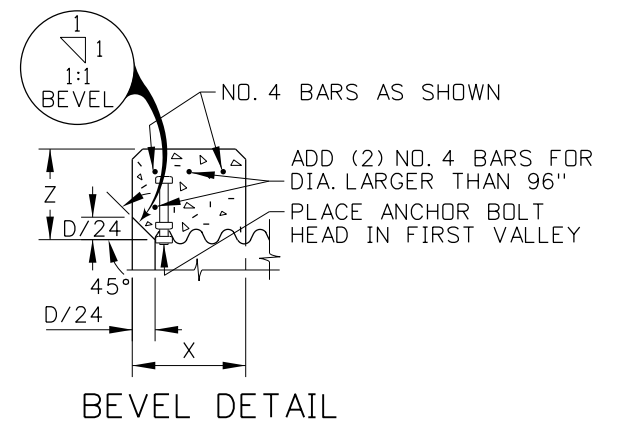
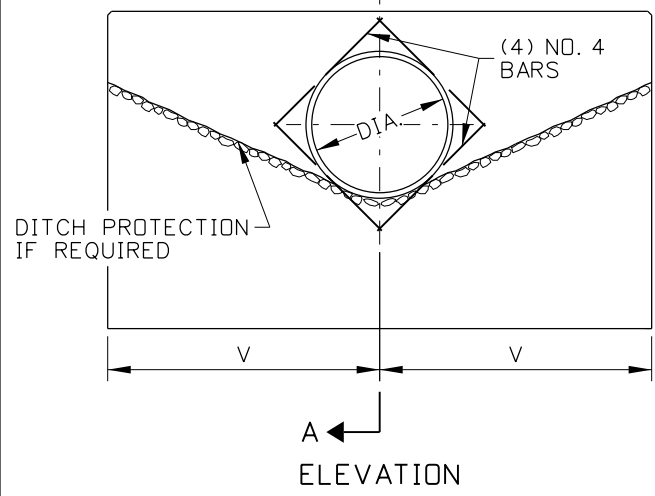

SUMMARY OF QUANTITIES					
DIA. (INCHES)	CONCRETE (CU. YD.)	METAL REINF. (LBS.)	DIA. (INCHES) CON'T.	CONCRETE (CU. YD.) CON'T.	METAL REINF. (LBS.) CON'T.
18	0.6	45	72	4.1	435
24	0.9	65	84	5.6	535
30	1.2	85	96	6.9	640
36	1.2	75	108	9.8	795
42	1.4	90	120	12.5	955
48	1.7	105	144	20.3	1,255
54	2.3	125	180	37.6	1,820
60	2.6	145			

NOTE: QUANTITIES SHOWN ARE FOR CORR. METAL PIPE (CMP)

INLET STRUCTURE (CULVERT SIZES 18" TO LESS THAN 36" DIA.)

NOTES

- ENSURE THAT ANCHOR BOLT AND NUT MATERIAL CONFORMS TO ASTM A307. GALVANIZE BOLTS AND NUTS AFTER FABRICATION IN ACCORDANCE WITH AASHTO M 232. ANCHOR BOLTS ARE NOT REQUIRED FOR CONCRETE PIPE.
- THE DEPTH OF THE CUTOFF WALL SHOWN MAY BE REDUCED IF ROCK IS ENCOUNTERED AT A HIGHER ELEVATION.
- TO PERMIT THE PLACEMENT AND TAMPING OF BACKFILL MATERIAL BETWEEN MULTIPLE PIPES, PROVIDE A CLEAR SPACE OF ONE-HALF THE DIAMETER OF THE LARGER PIPE. ENSURE THAT THE CLEAR SPACE DOES NOT EXCEED 3 FEET.
- WHEN USING PERVIOUS BEDDING AND BACKFILL MATERIAL, PREVENT SEEPAGE AND PIPING BY PLACING IMPERVIOUS MATERIAL AT THE INLET. CUTOFF COLLARS MAY BE USED INSTEAD OF IMPERVIOUS MATERIAL.
- USE ENTRANCE LOSS COEFFICIENT $K_e=0.2$ FOR BEVELED ENTRANCE.
- WHEN CULVERT IS SKEWED TO EMBANKMENT, THE EMBANKMENT MAY BE CONTOURED AS SHOWN.
- COVER REINFORCING STEEL WITH A MINIMUM CONCRETE DEPTH OF 2".
- ALL EDGES TO HAVE 3/4" CHAMFER OR TOOLED EDGES.
- THIS INLET IS TO BE USED ONLY OUTSIDE OF THE CLEAR ZONE, OR BEHIND GUARDRAIL.
- NOT TO SCALE.

ORIGINAL STORED AT: ITD, Headquarters 3311 West State Boise, Idaho

ORIGINAL SIGNED BY: RYAN D. LANCASTER
DATE ORIGINAL SIGNED: DECEMBER 17, 2012

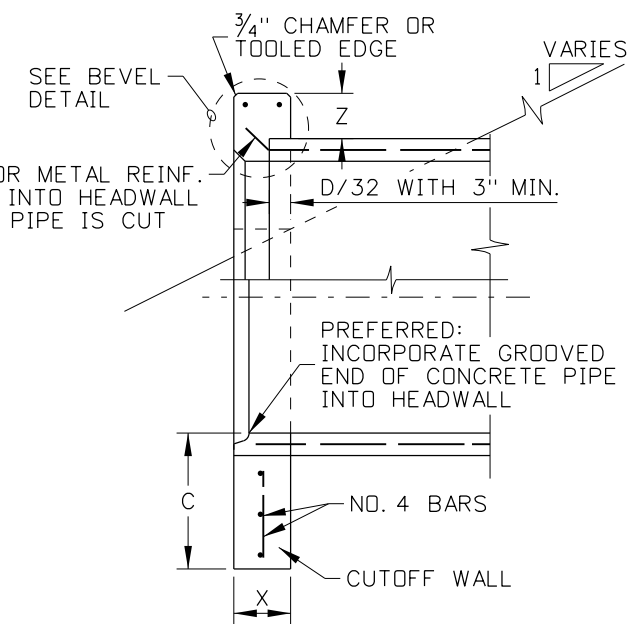
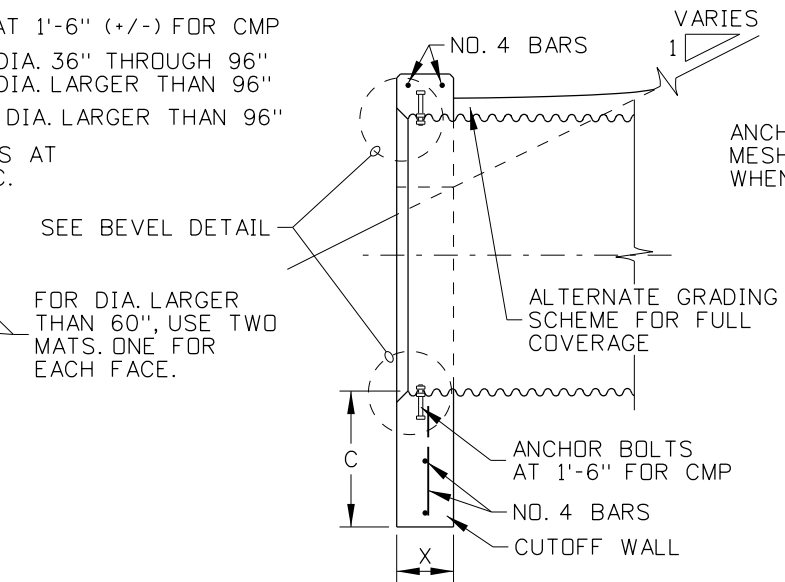
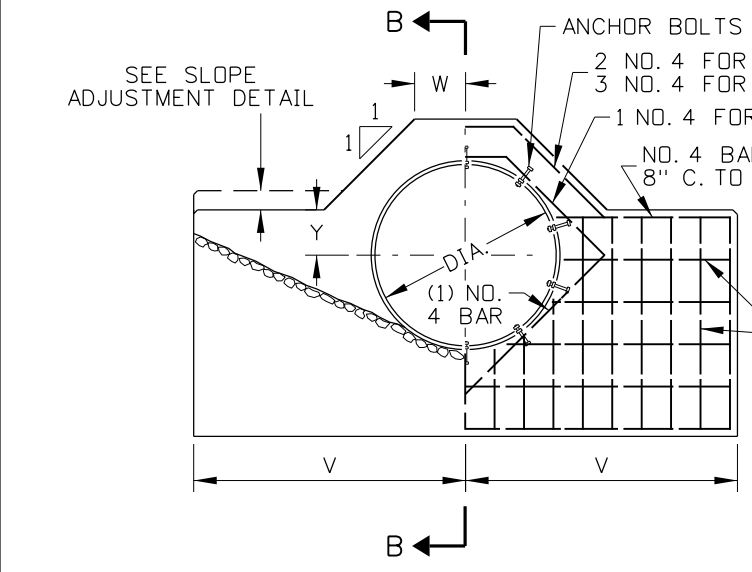

INLET STRUCTURE (CULVERT SIZES 36" TO 180" DIA.)

REVISIONS							
NO.	DATE	BY	NO.	DATE	BY	NO.	DATE
1	01-97	MSM					
2	11-00	MSM					
3	07-02	MSM					
4	03-05	MSM					
5	12-12	RDL					

SCALES SHOWN ARE FOR 11" X 17" PRINTS ONLY

CADD FILE NAME: 609-1_1212.dgn

DRAWING DATE: JANUARY, 1989

IDAHO TRANSPORTATION DEPARTMENT

BOISE IDAHO

ORIGINAL SIGNED BY: LOREN THOMAS
HIGHWAYS PROGRAM OVERSIGHT ENGINEER

ORIGINAL SIGNED BY: TOM COLE
CHIEF ENGINEER

STANDARD DRAWING

CULVERT INLET HEADWALL

English

STANDARD DRAWING NO. 609-1

SHEET 1 OF 1