

ELEVATION

* a S=SPAN & R=RISE:
 "D/24" VALUE=((S+R)/2)/24
 "D/12" VALUE=((S+R)/2)/12

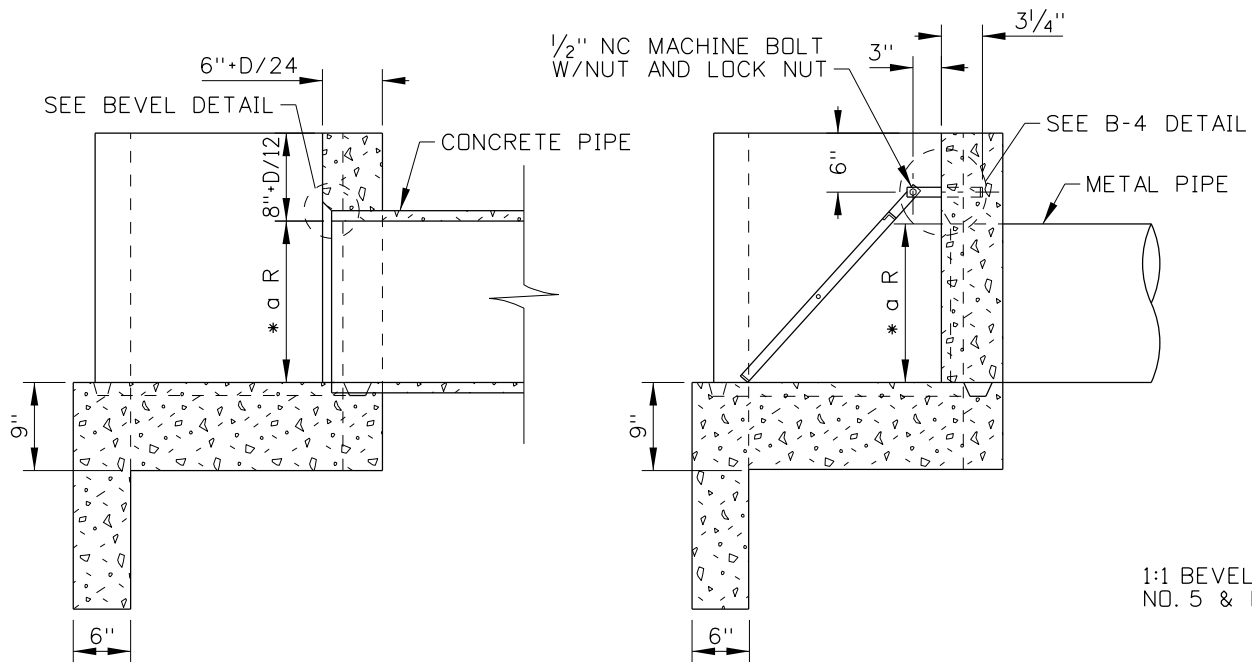

SECTION A-A

SECTION B-B

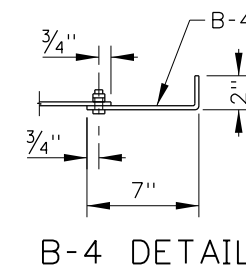

B-4 DETAIL

1:1 BEVEL (SEE NOTE NO. 5 & BEVEL DETAIL)

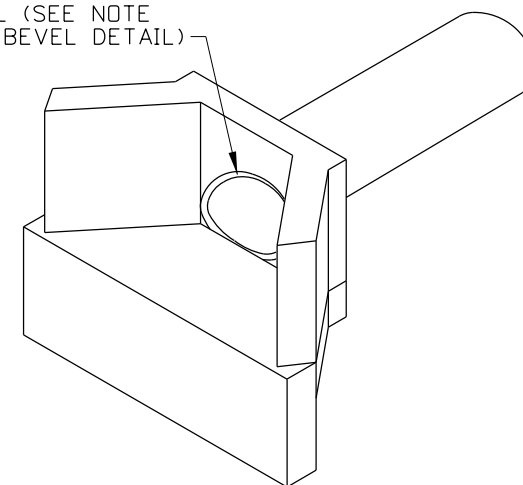

ISOMETRIC VIEW

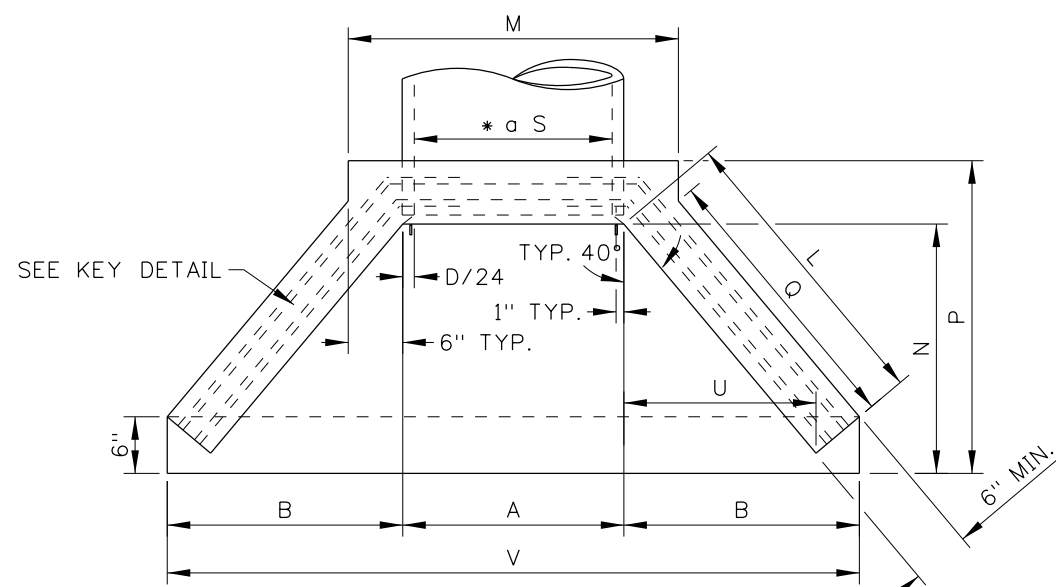

PLAN

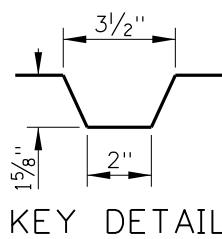

KEY DETAIL

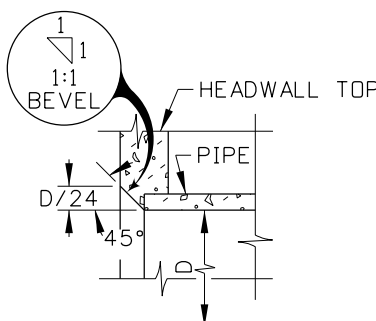

BEVEL DETAIL

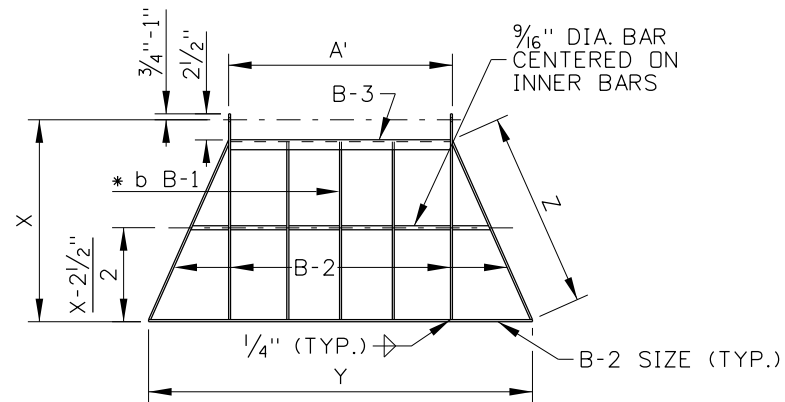

* b BARS SHALL BE EQUALLY SPACED IN GRATE NOT TO EXCEED 8" CENTER TO CENTER OR LESS THAN 6" CENTER TO CENTER.

INLET GRATE DETAIL

REVISIONS							
NO.	DATE	BY	NO.	DATE	BY	NO.	DATE
1	10-69		6	10-01	MSM		
2	03-92	MSM	7	06-03	MSM		
3	12-92	TMR	8	03-05	MSM		
4	05-95	MSM					
5	04-99	MSM					

SCALES SHOWN ARE FOR 11" X 17" PRINTS ONLY
 CADD FILE NAME: 609-4_0305.dgn
 DRAWING DATE: AUGUST, 1968

IDAHO TRANSPORTATION DEPARTMENT

BOISE IDAHO

ORIGINAL SIGNED BY: LOREN THOMAS
 ASSISTANT CHIEF ENGINEER (DEVELOPMENT)
 ORIGINAL SIGNED BY: STEVEN HUTCHINSON
 CHIEF ENGINEER

STANDARD DRAWING
CONCRETE HEADWALL FOR ARCH PIPE CULVERT
 REQUIRES SHEET 2 OF 2

English
 STANDARD DRAWING NO.
609-4
 SHEET 1 OF 2

ORIGINAL STORED AT: ITD, Headquarters 3311 West State Boise, Idaho

ORIGINAL SIGNED BY: MILDRED L. MILLER
 DATE ORIGINAL SIGNED: MARCH 4, 2005

METAL REINFORCEMENT TABLE			
MARK	LOCATION	BAR SIZE	SKETCH
F-1	FLOOR	NO. 4	
L-1	TOP & BOTOM OF INLET LIP IN FLOOR	NO. 4	
H-1A	HORIZ. IN TOP OF WING WALL & IN FLOOR BACK WALL	NO. 4	
H-1B	HORIZ. IN WING WALL BETWEEN H-1As'	NO. 4	
H-2	VERT. IN BCKWL. WALL BETWEEN AROUND PIPE	NO. 4	
W-1A	EACH SIDE OF PIPE IN BACKWALL, FLOOR, & INLET LIP	NO. 4	
W-1B	IN FLOOR, & INLET LIP	NO. 4	
W-1C	IN FLOOR, & INLET LIP	NO. 4	
L-2	VERTICAL IN FLOOR, & INLET LIP	NO. 4	
W-2	VERTICAL IN WING WALLS	NO. 4	

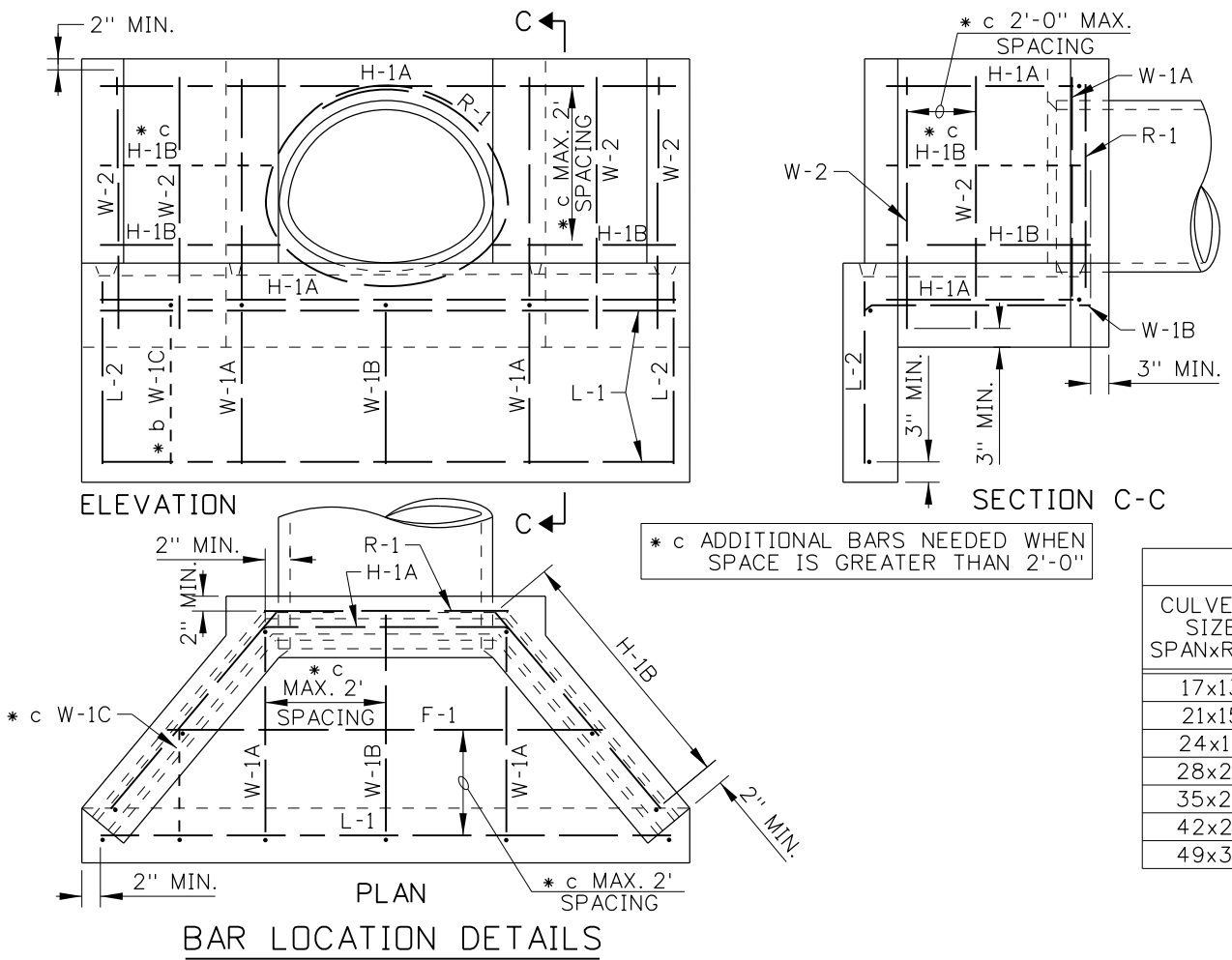

CULVERT SIZE SPANxRISE	CONCRETE (C.Y.)			
	WING & BCKWL.	FLOOR	LIP	TOTAL
17x13	0.2	0.3	0.2	0.7
21x15	0.3	0.3	0.2	0.8
24x18	0.4	0.4	0.2	1.0
28x20	0.4	0.5	0.2	1.1
35x24	0.5	0.7	0.2	1.4
42x29	0.8	0.9	0.2	1.9
49x33	1.0	1.1	0.3	2.4

CULVERT SIZE SPANxRISE	GRATE DIMENSION & MATERIALS TABLE							
	IN INCHES							
	DIMENSIONS				BAR SIZES			
	A'	* d X	Y	Z	B-1	B-2	B-3	B-4
17x13	17 1/4	21	36 7/8	17 3/4	1x1/4	1 1/4x1/4	1 1/4x1 1/4x1/4	1x1/4x9
21x15	21 1/2	24 1/8	44 1/2	26 1/2	1x1/4	1 1/4x1/4	1 1/4x1 1/4x1/4	1x1/4x9
24x18	24 3/4	28 3/4	53 3/8	30 1/8	1x1/4	1 1/4x1/4	1 1/4x1 1/4x1/4	1x1/4x9
28x20	29	31 1/8	61 1/2	33 1/2	1x1/4	1 1/4x1/4	1 1/4x1 1/4x1/4	1x1/4x9
35x24	36 1/2	38 1/4	76 3/4	41	1x1/4	1 1/4x1/4	1 1/4x1 1/4x1/4	1x1/4x9
42x29	43 1/2	46	93	50	1 1/4x1/4	1 1/2x1/4	1 1/2x1 1/2x1/4	1 1/2x1/4x9
49x33	51 1/2	52 1/4	108	57 1/8	1 1/2x1/4	1 3/4x1/4	1 3/4x1 3/4x1/4	1 3/4x1/4x9

* d ALLOW 3/4"-1" EXTRA BAR LENGTH FOR HOLE FABRICATION

HEADWALL DIMENSION TABLE											
CULVERT SIZE SPANxRISE	((S+R)/2)/24 D/24	IN INCHES									
		A	B	H	L	M	N	P	Q	U	V
17x13	5/8	18 1/4	21 1/2	22 1/4	26 1/4	30 1/4	22 1/4	28 7/8	24	16 7/8	61 1/4
21x15	3/4	23 3/8	23 3/8	24 1/2	29 1/4	34 1/2	24 1/2	31 1/4	27	18 3/4	69 1/4
24x18	7/8	26 1/8	26 1/8	27 3/4	33 1/2	37 3/4	27 3/4	34 5/8	31 3/8	21 1/2	78
28x20	1	28	28	30	36 3/8	42	30	37	34 1/4	23 3/8	86
35x24	1 1/4	31 3/4	31 3/4	34 1/2	42 1/4	49 1/2	34 1/2	41 3/4	40	27 1/8	101
42x29	1 1/2	36 1/2	36 1/2	40	49 1/2	57	40	47 1/2	47 3/8	31 3/4	118
49x33	1 3/4	40 1/8	40 1/8	44 3/8	55 1/8	64 1/2	44 3/8	52 1/8	53	31 3/4	132 3/4

METAL REINFORCEMENT TABLE														
BAR	NOMINAL PIPE SIZE DIAMETER (IN.)													
	17x13		21x15		24x18		28x20		35x24		42x29		49x33	
	NO.	LGTH.	NO.	LGTH.	NO.	LGTH.	NO.	LGTH.	NO.	LGTH.	NO.	LGTH.	NO.	LGTH.
F-1	1	40 1/2	1	48	1	54	1	60	1	70	1	82	1	96
H-1A	2	74	2	83	2	94	2	105	2	124	2	146	2	165
H-1B	2	25	2	30	4	34	4	38	4	44	4	52	4	58
L-1	2	57	2	65	2	74	2	82	2	97	2	114	2	128
L-2	2	19	2	19	2	19	2	19	2	19	2	19	2	19
R-1	1	72	1	82	1	92	1	102	1	118	1	138	1	153
W-1A	2	61 1/2	2	67 1/2	2	74	2	79 1/2	2	87 1/2	2	98 1/2	2	107
W-1B	0	N/A	2	41 1/2	2	45	2	48	2	52	2	59 1/2	2	62
W-1C	0	N/A	1	N/A	1	32	1	33 1/2	1	36	1	39	2	40
W-2	4	26	4	29 1/2	4	32	4	34	4	38 1/2	6	44	6	48
TOT. WT.	39 lbs.		46 lbs.		58 lbs.		64 lbs.		73 lbs.		90 lbs.		101 lbs.	

NOTES

- THIS HEADWALL SHALL BE USED ONLY WHEN PROTECTED BY GUARDRAIL OR INSTALLED OUTSIDE THE CLEAR ZONE.
- CAST-IN-PLACE HEADWALLS SHALL CONFORM TO SECTION 609 - MINOR STRUCTURES, OF THE CURRENT ITD STANDARD SPECIFICATIONS FOR HIGHWAY CONSTRUCTION.
- THE METAL REINFORCEMENT SHALL BE NO. 4 BARS. ALL REINFORCEMENT SHALL HAVE A MINIMUM CONCRETE COVER OF 2" AND 3" MINIMUM COVER IF CAST AGAINST EARTH.
- ALL EDGES TO HAVE 3/4" CHAMFER OR TOOLED EDGES.
- ALL PIPE CULVERTS WITH A CONCRETE HEADWALL SHALL HAVE THE INLET HEADWALLS BEVELED. USE ENTRANCE LOSS COEFFICIENT $K_e = 0.2$ FOR BEVELED ENTRANCES.
- THE METAL FOR THE GRATE SHALL MEET THE REQUIREMENTS OF ASTM A 36. WELDING OF THE METAL GRATE SHALL MEET THE REQUIREMENTS OF THE AMERICAN WELDING SOCIETY D1.1. GRATES FOR INLET HEADWALLS WILL BE REQUIRED ONLY WHEN SHOWN ON THE ROADWAY PLANS. GRATES NEED NOT BE PAINTED OR GALVANIZED.
- USE CONCRETE, METAL, OR PLASTIC PIPE WITH HEADWALL (CONCRETE PIPE SHOWN ON DRAWING).
- NOT TO SCALE.

ORIGINAL STORED AT: ITD, Headquarters 3311 West State Boise, Idaho

ORIGINAL SIGNED BY: MILDRED L. MILLER DATE ORIGINAL SIGNED: MARCH 4, 2005

REVISIONS							
NO.	DATE	BY	NO.	DATE	BY	NO.	DATE
1	10-69		6	10-01	MSM		
2	03-92	MSM	7	06-03	MSM		
3	12-92	TMR	8	03-05	MSM		
4	05-95	MSM					
5	04-99	MSM					

SCALES SHOWN ARE FOR 11" X 17" PRINTS ONLY
CADD FILE NAME: 609-4_0305.dgn
DRAWING DATE: AUGUST, 1968

IDAHO TRANSPORTATION DEPARTMENT

BOISE IDAHO

ORIGINAL SIGNED BY: LOREN THOMAS
ASSISTANT CHIEF ENGINEER (DEVELOPMENT)
ORIGINAL SIGNED BY: STEVEN HUTCHINSON
CHIEF ENGINEER

STANDARD DRAWING
CONCRETE HEADWALL FOR ARCH PIPE CULVERT
REQUIRES SHEET 1 OF 2

English
STANDARD DRAWING NO.
609-4
SHEET 2 OF 2