

MARKINGS DETAIL

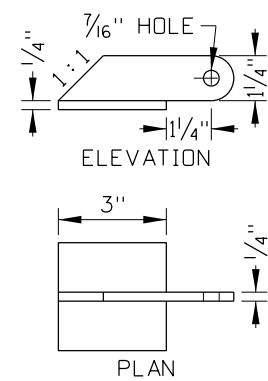

WING TOP PLATE DETAIL

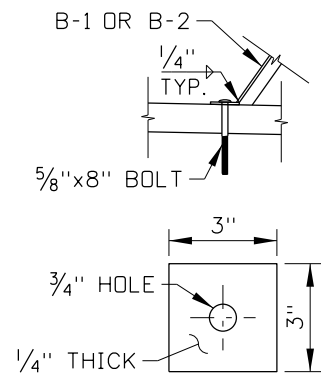

WING BASE PLATE DETAIL

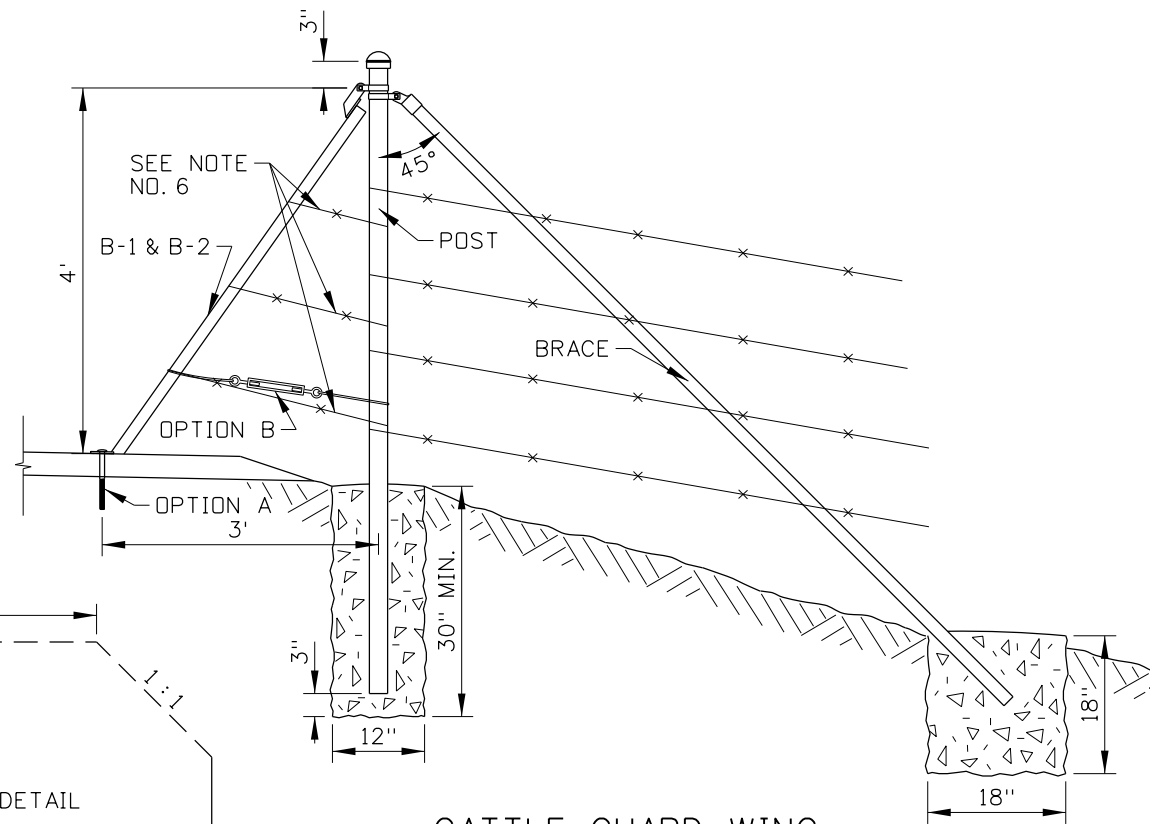

CATTLE GUARD WING

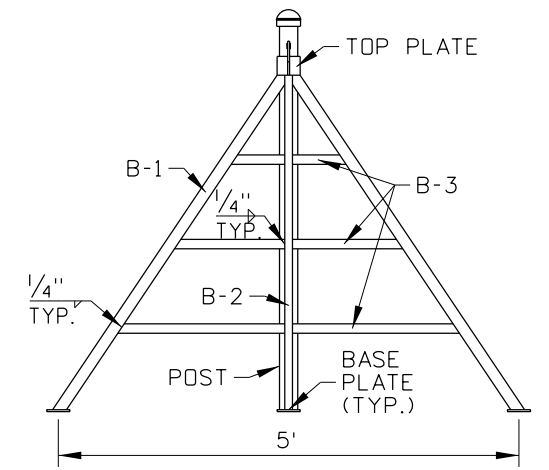

CATTLE GUARD WING ELEVATION

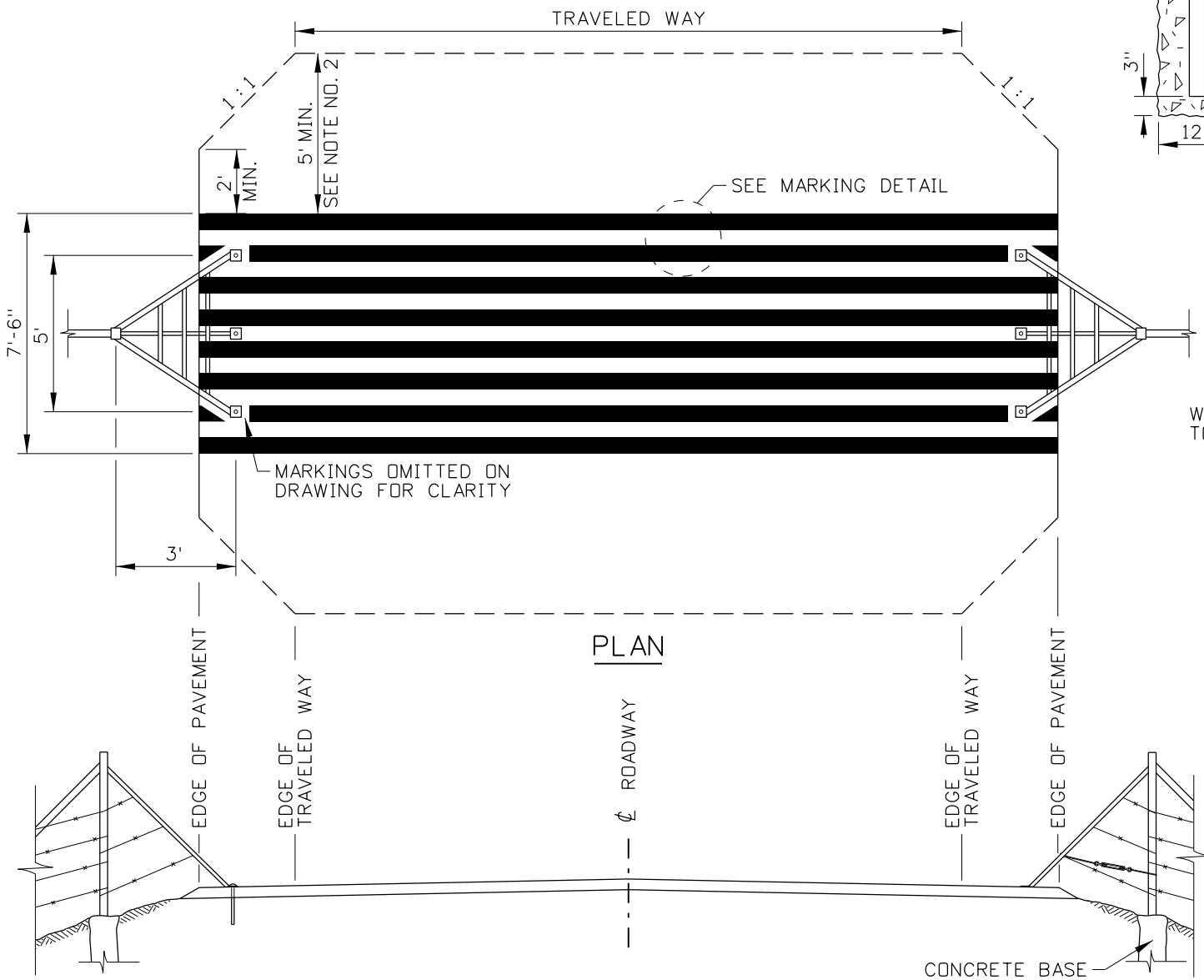

OPTION A SHOWN

ELEVATION

OPTION B SHOWN

MATERIALS TABLE		
COMPONENT	QUANTITY	SIZE
POST	2	2 3/8" DIA. x 8'-0"
BRACE	2	1 5/8" DIA. x 10'-0"
B-1: WING SIDE LEGS	4	1/2"x1 1/2"x1/4"x68" ANGLE
B-2: WING CENTER LEG	2	1"x1/4"x60" FLAT
B-3: WING CROSS BARS	2	1/2"x1 1/2"x1/4" ANGLE 16", 31", & 46" LENGTHS
WING BASE PLATE	6	3"x3"x1/4"
WING TOP PLATE	2	SEE DETAIL
BRACE BAND	4	2 3/8" DIA.
POST CAP	2	2 3/8" DIA.
BRACE END CAP	2	1 5/8" DIA.
NUTS & BOLTS	4	5/16"x1 1/4" BOLT AND NUT
BASE BOLTS (OPTION A)	6	5/8"x8"
TURNBUCKLE (OPTION B)	2	3/8"

NOTES

- IF THE CATTLE GUARD IS CONSTRUCTED ON A PAVED ROAD WITH PAVEMENT MARKINGS, TERMINATE OR OBLITERATE THE LONGITUDINAL PAVEMENT MARKINGS 25 FEET FROM THE CATTLE GUARD MARKINGS.
- IF THE CATTLE GUARD IS CONSTRUCTED ON AN UNPAVED ROAD, PAVE THE CATTLE GUARD AREA AND EXTEND PAVEMENT A MINIMUM OF FIVE FEET BEYOND WHERE THE CATTLE GUARD IS TO BE MARKED.
- MARK THE CATTLE GUARD PRIOR TO ATTACHING THE CATTLE GUARD WINGS. USE WHITE WATERBORNE PAINT OR THERMOPLASTIC PAVEMENT MARKINGS. MARK A MINIMUM OF EIGHT LINES.
- SECURE THE CATTLE GUARD WINGS TO PAVEMENT WITH ONE OF THE FOLLOWING OPTIONS:
 OPTION A:
 INSERT 5/8"x8" BOLTS INTO PRE-DRILLED HOLES IN THE PAVEMENT. ENSURE THAT THE BOLT HEAD IS FLUSH WITH THE BASE PLATE.
 OPTION B:
 PLACE A 3/8" TURNBUCKLE FASTENED WITH 10 GAUGE OR THICKER WIRE BETWEEN THE WING CENTER MEMBER (B-2) AND THE BRACE POST. TIGHTEN TURNBUCKLE TO PRESS WING FEET TO ROADWAY PAVEMENT.
- PAINT THE CATTLE GUARD WINGS YELLOW WITH ITD FORMULA NO. 9.
- TIE A MINIMUM OF THREE BARBED WIRES FROM THE POST TO THE INTERSECTIONS OF THE WING B-1 AND B-3 ANGLE BARS.
- DRAWINGS NOT TO SCALE.

ORIGINAL STORED AT: ITD, Headquarters 3311 West State Boise, Idaho

ORIGINAL SIGNED BY: RYAN D. LANCASTER
DATE ORIGINAL SIGNED: DECEMBER 17, 2015

REVISIONS							
NO.	DATE	BY	NO.	DATE	BY	NO.	DATE
1	08-04	MSM					
2	10-05	MSM					
3	12-12	RDL					
4	12-15	RDL					

SCALES SHOWN ARE FOR 11" X 17" PRINTS ONLY
 CADD FILE NAME: 611-2_1215.dgn
 DRAWING DATE: JANUARY, 2004

IDAHO TRANSPORTATION DEPARTMENT
 BOISE IDAHO

ORIGINAL SIGNED BY: KEVIN SABLAN
 DESIGN/TRAFFIC SERVICES ENGINEER

STANDARD DRAWING
 CATTLE GUARD PAVEMENT MARKINGS

English
 STANDARD DRAWING NO. 611-2
 SHEET 1 OF 1