

BULLNOSE DIMENSION TABLE											
	DESIGN	WIDTH	A	B	C	D	E	DIST 1	DIST 2	R1	CABLE
SYMMETRICAL	1	14'-9 <sup>1</sup> / <sub>8</sub> "	9'-8"	11'-8"	13'-1"	13'-11"	14'-2 <sup>1</sup> / <sub>2</sub> "	15'-10"	34'-7"	5'-2 <sup>3</sup> / <sub>16</sub> "	14'-6"
	2	19'-5 <sup>5</sup> / <sub>8</sub> "	14'-6 <sup>3</sup> / <sub>8</sub> "	16'-6"	17'-11"	18'-9 <sup>1</sup> / <sub>8</sub> "	19'-5 <sup>5</sup> / <sub>8</sub> "	17'-6"	36'-3"	7'-9 <sup>5</sup> / <sub>16</sub> "	20'-9 <sup>5</sup> / <sub>8</sub> "
	3	23'-10 <sup>3</sup> / <sub>4</sub> "	19'-4 <sup>3</sup> / <sub>8</sub> "	21'-4"	22'-9"	23'-7"	23'-10 <sup>3</sup> / <sub>4</sub> "	19'-2"	37'-11"	10'-4 <sup>3</sup> / <sub>8</sub> "	27'-1"
ASYMMETRICAL	1	VARIES	9'-8"	11'-6"	13'-1 <sup>1</sup> / <sub>16</sub> "	14'-3 <sup>7</sup> / <sub>8</sub> "	15'-3 <sup>1</sup> / <sub>16</sub> "	15'-10"	34'-7"	5'-2 <sup>3</sup> / <sub>16</sub> "	14'-6"
	2	VARIES	9'-8"	11'-3"	12'-6 <sup>1</sup> / <sub>16</sub> "	13'-6 <sup>7</sup> / <sub>8</sub> "	14'-3 <sup>1</sup> / <sub>16</sub> "	15'-10"	34'-7"	5'-2 <sup>3</sup> / <sub>16</sub> "	14'-6"

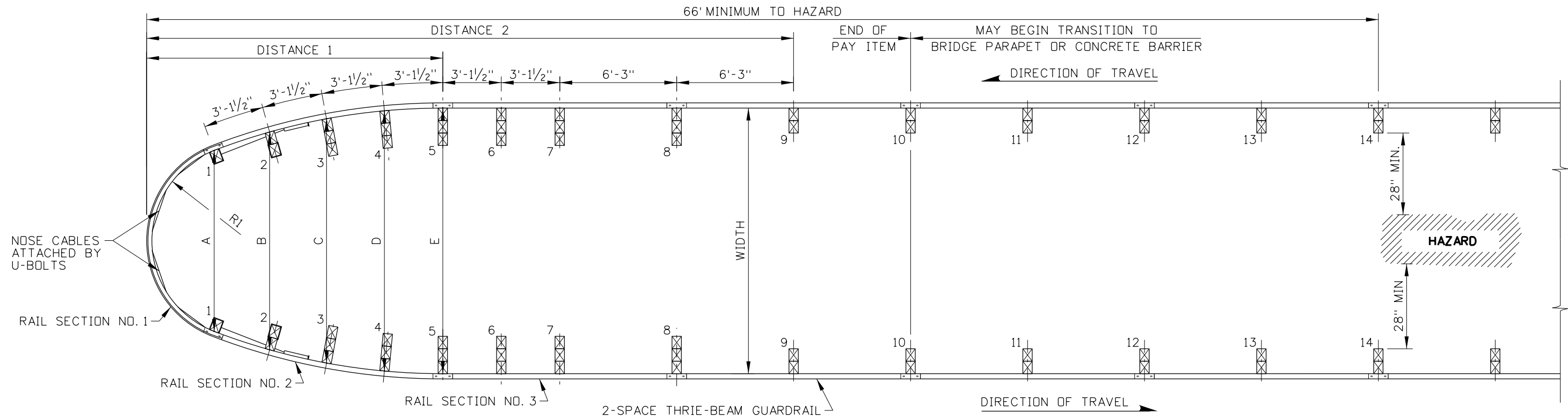

SYMMETRICAL DESIGNS 1, 2, & 3

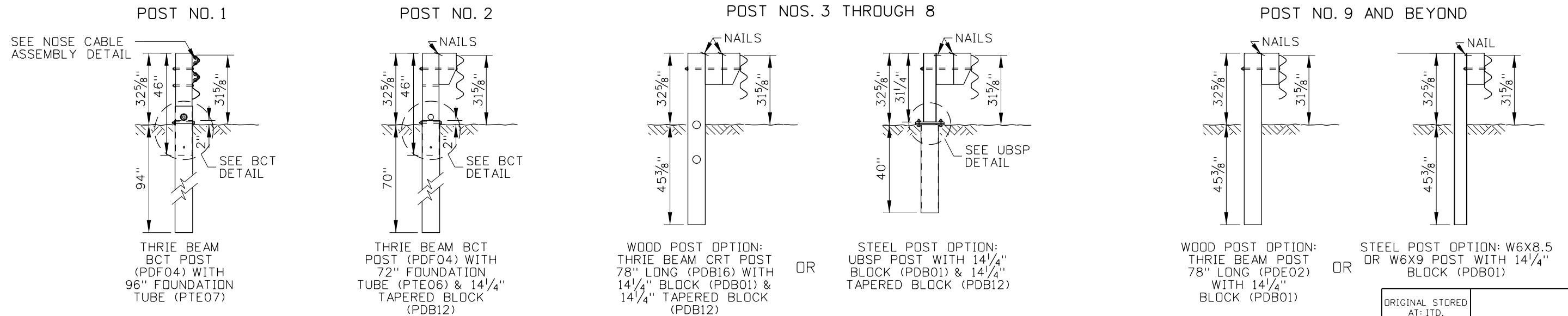

POST ASSEMBLY DETAILS

ORIGINAL STORED AT: ITD, Headquarters 3311 West State Boise, Idaho

ORIGINAL SIGNED BY: RYAN D. LANCASTER DATE: ORIGINAL SIGNED: DECEMBER 8, 2015

REVISIONS							
NO.	DATE	BY	NO.	DATE	BY	NO.	DATE
1	06-02	MSM	6	09-15	RDL		
2	10-03	MSM					
3	12-04	MSM					
4	05-06	MSM					
5	09-10	MGL					

SCALES SHOWN ARE FOR 11" X 17" PRINTS ONLY  
 CADD FILE NAME: 613-1\_1215.dgn  
 DRAWING DATE: NOVEMBER, 2001

**IDAHO TRANSPORTATION DEPARTMENT**



BOISE IDAHO

ORIGINAL SIGNED BY: TED E. MASON for DESIGN/TRAFFIC SERVICES ENGINEER

STANDARD DRAWING  
**BULLNOSE CRASH CUSHION**

**English**  
 STANDARD DRAWING NO. 613-1  
 SHEET 1 OF 7

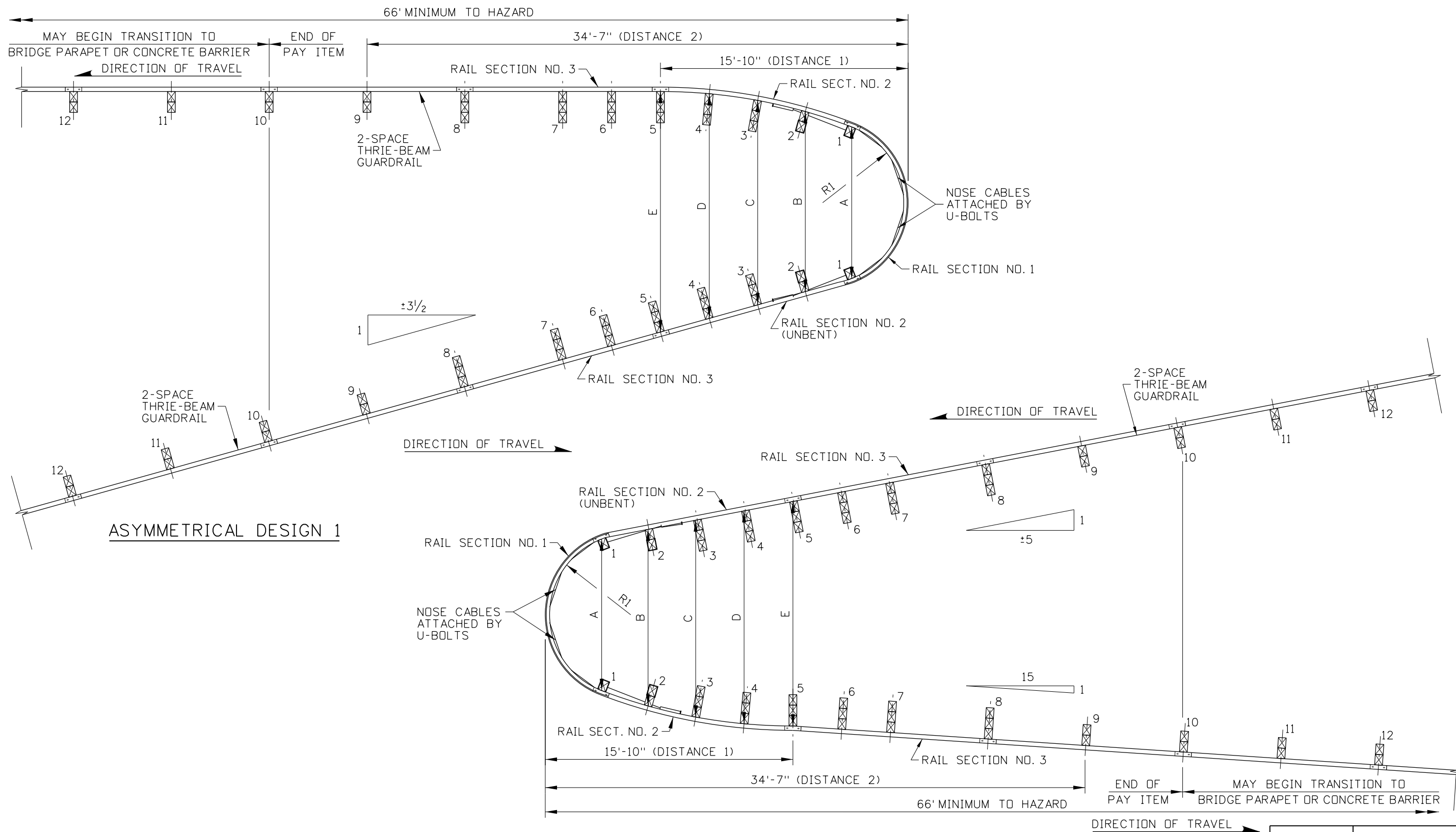

REVISIONS								
NO.	DATE	BY	NO.	DATE	BY	NO.	DATE	BY
1	06-02	MSM	6	09-15	RDL			
2	10-03	MSM						
3	12-04	MSM						
4	05-06	MSM						
5	09-10	MGL						

SCALES SHOWN ARE FOR 11" X 17" PRINTS ONLY

CADD FILE NAME: 613-1\_1215.dgn

DRAWING DATE: NOVEMBER, 2001

**IDAHO TRANSPORTATION DEPARTMENT**



BOISE IDAHO

ORIGINAL SIGNED BY: TED E. MASON for DESIGN/TRAFFIC SERVICES ENGINEER

STANDARD DRAWING

**BULLNOSE CRASH CUSHION**

ORIGINAL STORED AT: ITD, Headquarters 3311 West State Boise, Idaho

**English**

STANDARD DRAWING NO. **613-1**

SHEET 2 OF 7

ORIGINAL SIGNED BY: RYAN D. LANCASTER  
DATE ORIGINAL SIGNED: DECEMBER 8, 2015

**BULLNOSE CRASH CUSHION HARDWARE COMPONENTS TABLE (SEE NOTE NO. 6)**

COMPONENT DESCRIPTION	QUANTITY										TASK FORCE 13 HARDWARE GUIDE DESIGNATOR	MATERIAL SPECIFICATION
	WOOD POST					STEEL POST						
	SYMMETRICAL		ASYMMETRICAL			SYMMETRICAL		ASYMMETRICAL				
	1	2	3	1	2	1	2	3	1	2		
SLOTTED AND BENT 12'-6" THRIE-BEAM GUARDRAIL SECTION NO. 1 - RADIUS 5'-2 <sup>3</sup> / <sub>16</sub> "	1	-	-	1	1	1	-	-	1	1	RTM07a	12 GUAGE AASHTO M 180
SLOTTED AND BENT 9'-4 <sup>1</sup> / <sub>2</sub> " THRIE-BEAM GUARDRAIL SECTION NO. 1 - RADIUS 7'-9 <sup>5</sup> / <sub>16</sub> "	-	2	-	-	-	-	2	-	-	-	-----	12 GUAGE AASHTO M 180
SLOTTED AND BENT 12'-6" THRIE-BEAM GUARDRAIL SECTION NO. 1 - RADIUS 10'-4 <sup>3</sup> / <sub>8</sub> "	-	-	2	-	-	-	-	2	-	-	-----	12 GUAGE AASHTO M 180
SLOTTED AND BENT 12'-6" THRIE-BEAM GUARDRAIL SECTION NO. 2 - RADIUS 34'-1 <sup>1</sup> / <sub>16</sub> "	2	2	2	1	1	2	2	2	1	1	RTM07b	12 GUAGE AASHTO M 180
SLOTTED 12'-6" THRIE-BEAM GUARDRAIL SECTION NO. 2	-	-	-	1	1	-	-	-	1	1	RTM07b	12 GUAGE AASHTO M 180
SLOTTED 12'-6" THRIE-BEAM GUARDRAIL SECTION NO. 3	2	2	2	2	2	2	2	2	2	2	RTM07c	12 GUAGE AASHTO M 180
12'-6" 2-SPACE THRIE-BEAM GUARDRAIL	2	2	2	2	2	2	2	2	2	2	RTM02a	12 GUAGE AASHTO M 180
46" THRIE-BEAM GUARDRAIL BCT POST	4	4	4	4	4	4	4	4	4	4	PDF04	SYP GRADE NO. 1 OR BETTER
96" FOUNDATION TUBE	2	2	2	2	2	2	2	2	2	2	PTE07	ASTM A500 GRADE B
72" FOUNDATION TUBE	2	2	2	2	2	2	2	2	2	2	PTE06	ASTM A500 GRADE B
78" THRIE-BEAM GUARDRAIL CRT POST	12	12	12	12	12	-	-	-	-	-	PDB16	SYP GRADE NO. 1 OR BETTER
78" THRIE-BEAM GUARDRAIL TIMBER POST	4	4	4	4	4	-	-	-	-	-	PDE02	SYP GRADE NO. 1 OR BETTER
UBSP POST - TOP ASSEMBLY	-	-	-	-	-	12	12	12	12	12	-----	ASTM A36
UBSP POST - BOTTOM ASSEMBLY	-	-	-	-	-	12	12	12	12	12	-----	ASTM A36 (SHEAR PLATE), ASTM A500 GRADE B (TUBE)
78" W6X8.5X78" OR W6X9X78" STEEL POST	-	-	-	-	-	4	4	4	4	2	-----	ASTM A36
6"x8"x14 <sup>1</sup> / <sub>4</sub> " GUARDRAIL TIMBER BLOCKOUT (HOLE CENTERED FOR TIMBER POST)	14	14	14	14	14	-	-	-	-	-	PDB01 (PDB09)	SYP GRADE NO. 1 OR BETTER
6"x8"x14 <sup>1</sup> / <sub>4</sub> " GUARDRAIL TIMBER BLOCKOUT (HOLES OFFSET FOR STEEL POST)	-	-	-	-	-	14	14	14	14	14	PDB01 (PDB09)	SYP GRADE NO. 1 OR BETTER
6"x8"x14 <sup>1</sup> / <sub>4</sub> " TAPERED GUARDRAIL TIMBER BLOCKOUT (HOLE CENTERED FOR TIMBER POST)	14	14	14	14	14	2	2	2	2	2	PDB12	SYP GRADE NO. 1 OR BETTER
6"x8"x14 <sup>1</sup> / <sub>4</sub> " TAPERED GUARDRAIL TIMBER BLOCKOUT (HOLES OFFSET FOR STEEL POST)	-	-	-	-	-	12	12	12	12	12	PDB12 MODIFIED	SYP GRADE NO. 1 OR BETTER
6'-6" BCT ANCHOR CABLE	2	2	2	2	2	2	2	2	2	2	FCA01	6x19 OR 6x25 CABLE IWRC IPS
GUARDRAIL ANCHOR BRACKET AND BEARING PLATE	2	2	2	2	2	2	2	2	2	2	FPA01	ASTM A36
8"x8"x <sup>5</sup> / <sub>8</sub> " BCT BEARING PLATE	2	2	2	2	2	2	2	2	2	2	FPB01	ASTM A36
2 <sup>3</sup> / <sub>8</sub> " O.D. X 6" LONG BCT POST SLEEVE	2	2	2	2	2	2	2	2	2	2	FMM02	ASTM A53 GRADE B SCHEDULE 40
12 <sup>5</sup> / <sub>8</sub> " X 5 <sup>1</sup> / <sub>16</sub> " NOSE CABLE ANCHOR PLATE	4	4	4	4	4	4	4	4	4	4	-----	ASTM A36
<sup>5</sup> / <sub>8</sub> " DIA. X 14'-6" NOSE CABLE (6x19 OR 6x25)	2	-	-	2	2	2	-	-	2	2	-----	SEE NOSE CABLE DETAIL
<sup>5</sup> / <sub>8</sub> " DIA. X 20'-9 <sup>5</sup> / <sub>8</sub> " NOSE CABLE (6x19 OR 6x25)	-	2	-	-	-	-	2	-	-	-	-----	SEE NOSE CABLE DETAIL
<sup>5</sup> / <sub>8</sub> " DIA. X 27'-1" NOSE CABLE (6x19 OR 6x25)	-	-	2	-	-	-	-	2	-	-	-----	SEE NOSE CABLE DETAIL
16D DOUBLE HEAD NAIL	56	56	56	56	56	40	40	40	40	40	-----	N/A
<sup>1</sup> / <sub>4</sub> " DIA. U-BOLT (TO ATTACH NOSE CABLE TO RAIL SECTION NO. 1)	6	6	6	6	6	6	6	6	6	6	-----	ASTM A307 GALVANIZED
U-BOLT PLATE WASHER (TO ATTACH NOSE CABLE TO RAIL SECTION NO. 1)	6	6	6	6	6	6	6	6	6	6	-----	ASTM A307 GALVANIZED
<sup>1</sup> / <sub>4</sub> " DIA. HEX NUT (TO ATTACH NOSE CABLE TO RAIL SECTION NO. 1)	12	12	12	12	12	12	12	12	12	12	-----	ASTM A307 GALVANIZED
<sup>7</sup> / <sub>16</sub> " DIA. UNC-14 X 2 <sup>1</sup> / <sub>2</sub> " LONG HEX FULLY THREADED TAP BOLTS (FOR UBSP POSTS)	-	-	-	-	-	48	48	48	48	48	-----	SAE GRADE 5/ASTM A325
<sup>7</sup> / <sub>16</sub> " DIA. HEX NUT (FOR UBSP POSTS)	-	-	-	-	-	48	48	48	48	48	-----	ASTM A563DH GALVANIZED
<sup>7</sup> / <sub>16</sub> " DIA. FLAT WASHER (FOR UBSP POSTS)	-	-	-	-	-	192	192	192	192	192	-----	ASTM F436 GRADE 1 GALVANIZED
<sup>5</sup> / <sub>8</sub> " DIA. X 1 <sup>1</sup> / <sub>2</sub> " LONG GUARDRAIL BOLT AND RECESSED NUT	72	84	84	72	72	72	84	84	72	72	FBB01	ASTM A307 GALVANIZED
<sup>5</sup> / <sub>8</sub> " DIA. X 10" LONG GUARDRAIL BOLT AND RECESSED NUT	4	4	4	4	4	8	8	8	8	8	FBB03	ASTM A307 GALVANIZED
<sup>5</sup> / <sub>8</sub> " DIA. X 18" LONG GUARDRAIL BOLT AND RECESSED NUT	6	6	6	6	6	14	14	14	14	14	FBB04	ASTM A307 GALVANIZED
<sup>5</sup> / <sub>8</sub> " DIA. X 25" LONG GUARDRAIL BOLT AND RECESSED NUT	12	12	12	12	12	-	-	-	-	-	FBB05	ASTM A307 GALVANIZED
<sup>5</sup> / <sub>8</sub> " DIA. X 1 <sup>1</sup> / <sub>2</sub> " LONG HEX HEAD BOLT (FOR ANCHOR BRACKET)	16	16	16	16	16	16	16	16	16	16	FBX16a	GRADE A307 GALVANIZED
<sup>5</sup> / <sub>8</sub> " DIA. X 10" LONG HEX HEAD BOLT AND NUT (FOR BCT POSTS)	4	4	4	4	4	4	4	4	4	4	FBX16a	GRADE A307 GALVANIZED
<sup>5</sup> / <sub>8</sub> " DIA. FLAT WASHER	174	198	198	174	174	174	198	198	174	174	FWC16a	GRADE A307 GALVANIZED
<sup>7</sup> / <sub>8</sub> " DIA. X 7 <sup>1</sup> / <sub>2</sub> " LONG HEX HEAD BOLT AND NUT	4	4	4	4	4	4	4	4	4	4	FBX22a	GRADE A307 GALVANIZED
<sup>7</sup> / <sub>8</sub> " DIA. FLAT WASHER	8	8	8	8	8	8	8	8	8	8	FWC22a	GRADE A307 GALVANIZED
1" DIA. HEX NUT (FOR ANCHOR CABLE)	8	8	8	8	8	8	8	8	8	8	-----	ASTM A563DH
1" DIA. FLAT WASHER (FOR ANCHOR CABLE)	4	4	4	4	4	4	4	4	4	4	FWC24a	ASTM F436 GRADE 1 GALVANIZED

ORIGINAL STORED  
AT: ITD,  
Headquarters  
3311 West State  
Boise, Idaho

ORIGINAL SIGNED BY:  
RYAN D. LANCASTER  
DATE ORIGINAL SIGNED:  
DECEMBER 8, 2015

REVISIONS								
NO.	DATE	BY	NO.	DATE	BY	NO.	DATE	BY
1	06-02	MSM	6	09-15	RDL			
2	10-03	MSM						
3	12-04	MSM						
4	05-06	MSM						
5	09-10	MGL						

SCALES SHOWN  
ARE FOR 11" X 17"  
PRINTS ONLY

CADD FILE NAME:  
613-1\_1215.dgn

DRAWING DATE:  
NOVEMBER, 2001

**IDAHO  
TRANSPORTATION  
DEPARTMENT**



BOISE IDAHO

ORIGINAL SIGNED BY: TED E. MASON *for*  
DESIGN/TRAFFIC SERVICES ENGINEER

STANDARD DRAWING

**BULLNOSE CRASH CUSHION**

**English**

STANDARD DRAWING NO.  
**613-1**

SHEET 3 OF 7

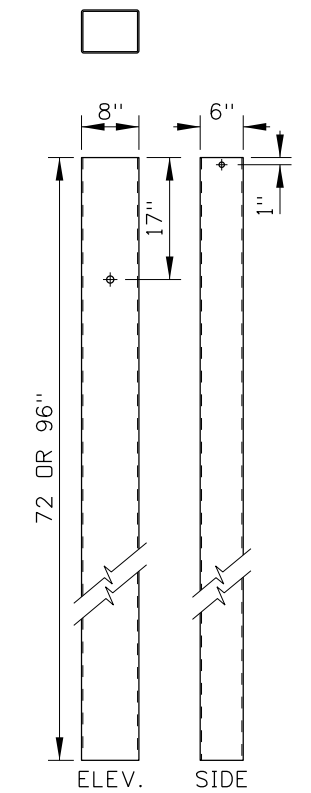

FOUNDATION TUBES  
POSTS 1 & 2  
(PTE06 & PTE07)

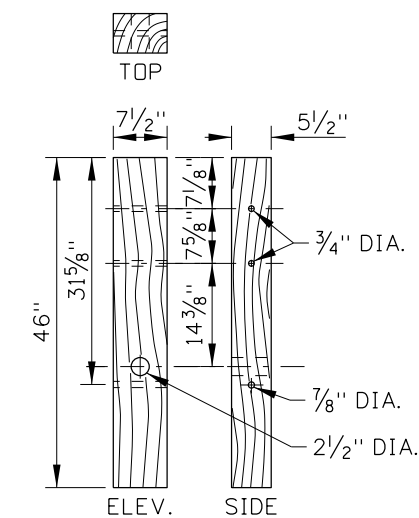

THRIE BEAM BCT POST  
POSTS 1 & 2  
(PDF04)

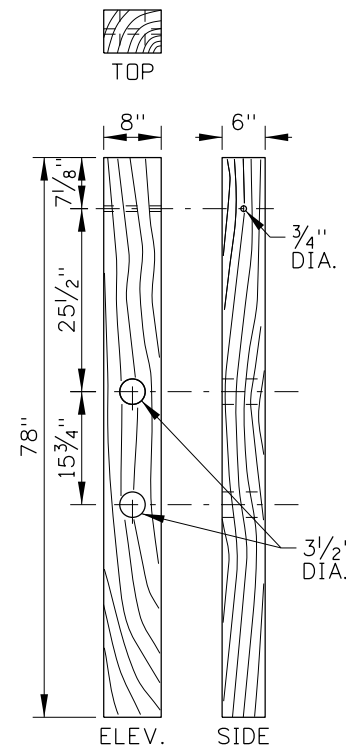

THRIE BEAM CRT POST  
POSTS 3 THROUGH 8  
(PDB16)

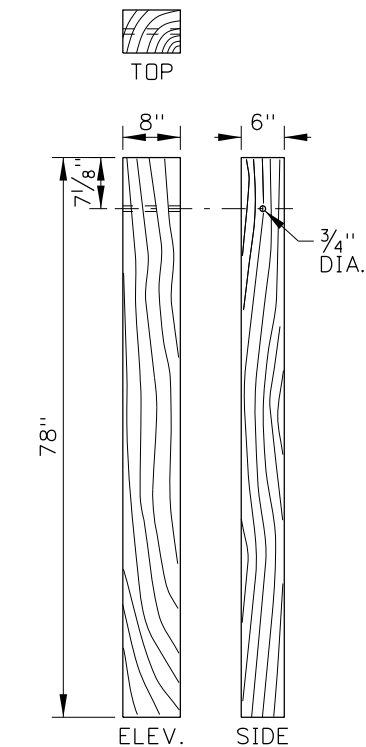

THRIE BEAM TIMBER POST  
POST 9 AND BEYOND  
(PDE02)

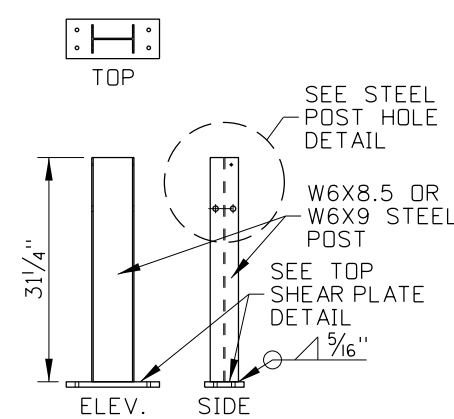

UBSP TOP ASSEMBLY  
POSTS 3 THROUGH 8

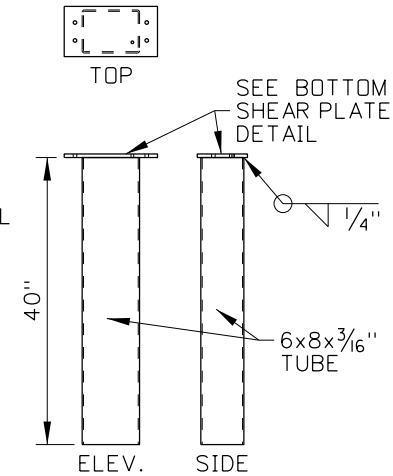

UBSP BOTTOM ASSEMBLY  
POSTS 3 THROUGH 8

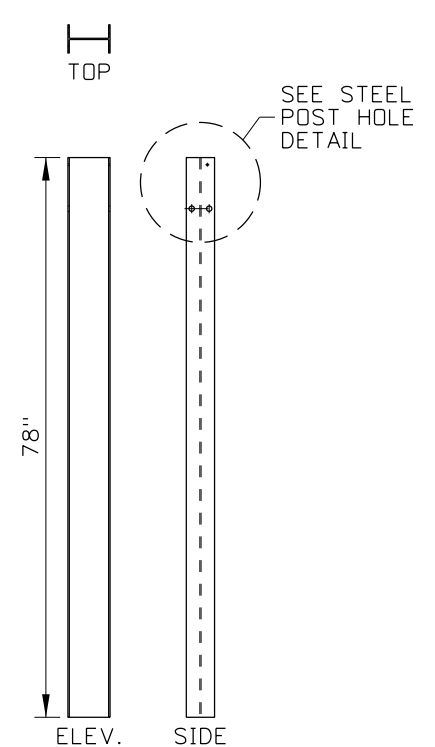

THRIE BEAM  
W6X8.5 OR W6X9  
STEEL POST  
POST 9 AND BEYOND

POST DETAILS

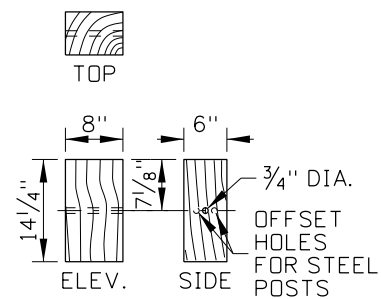

BLOCK  
(PDB01 & PDB09)

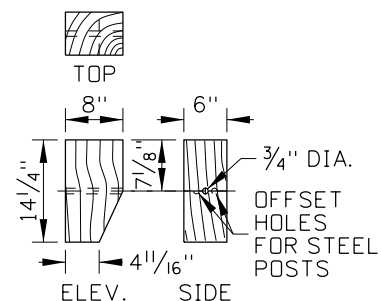

TAPERED BLOCK  
(PDB12)

BLOCK DETAILS

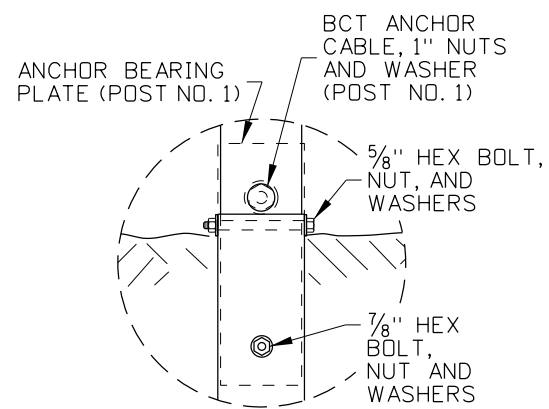

BCT DETAIL

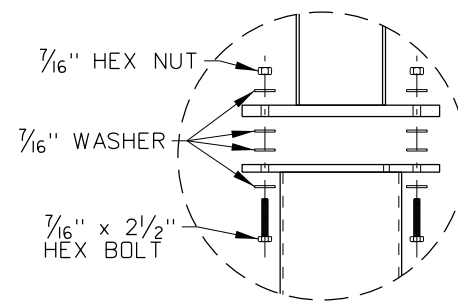

UBSP DETAIL

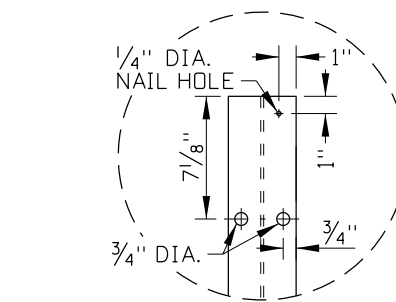

STEEL POST HOLE DETAIL

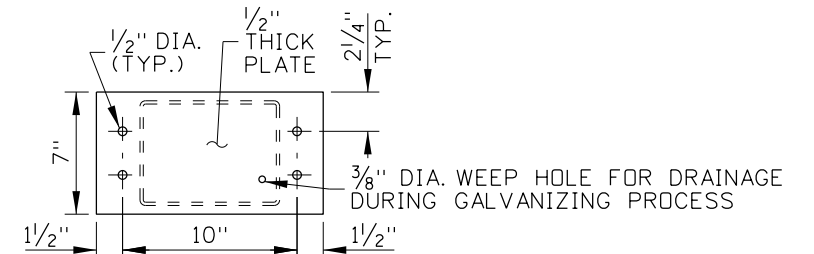

BOTTOM SHEAR PLATE DETAIL

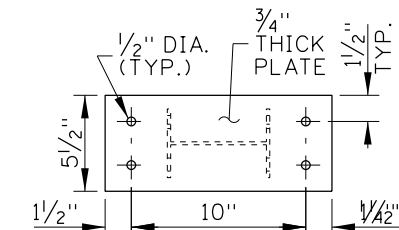

TOP SHEAR PLATE DETAIL

REVISIONS							
NO.	DATE	BY	NO.	DATE	BY	NO.	DATE
1	06-02	MSM	6	09-15	RDL		
2	10-03	MSM					
3	12-04	MSM					
4	05-06	MSM					
5	09-10	MGL					

SCALES SHOWN ARE FOR 11" X 17" PRINTS ONLY  
CADD FILE NAME: 613-1\_1215.dgn  
DRAWING DATE: NOVEMBER, 2001

IDAHO TRANSPORTATION DEPARTMENT  
BOISE IDAHO

ORIGINAL SIGNED BY: TED E. MASON for  
DESIGN/TRAFFIC SERVICES ENGINEER

STANDARD DRAWING  
BULLNOSE CRASH CUSHION

ORIGINAL STORED AT: ITD, Headquarters 3311 West State Boise, Idaho  
**English**  
STANDARD DRAWING NO. 613-1  
SHEET 4 OF 7

ORIGINAL SIGNED BY: RYAN D. LANCASTER  
DATE ORIGINAL SIGNED: DECEMBER 8, 2015

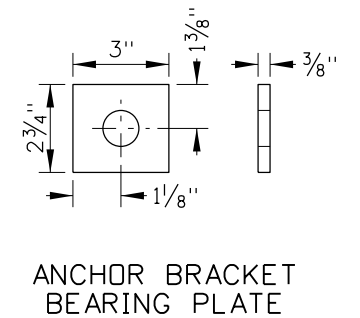
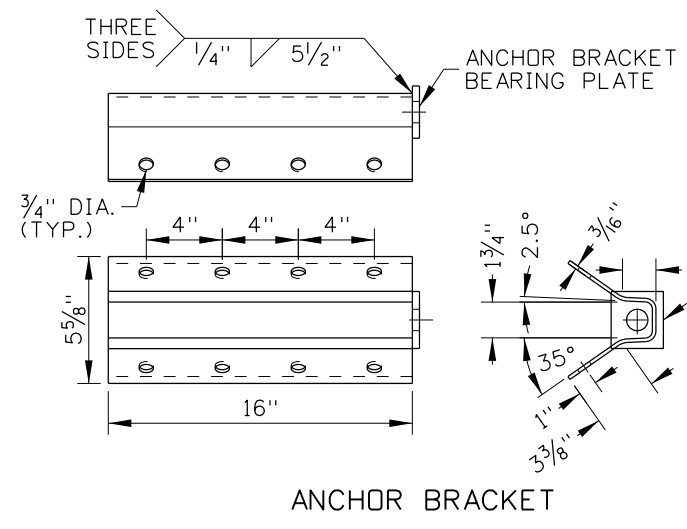
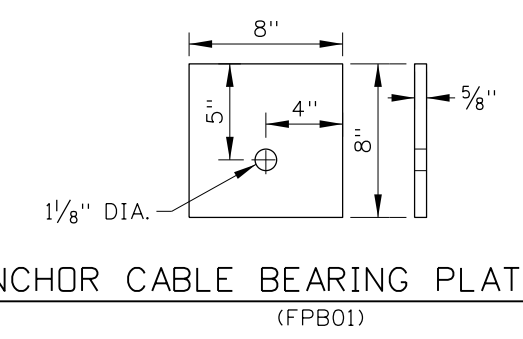
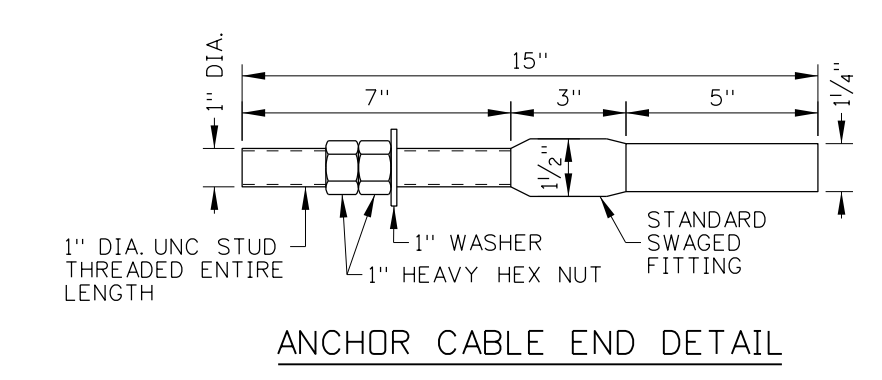
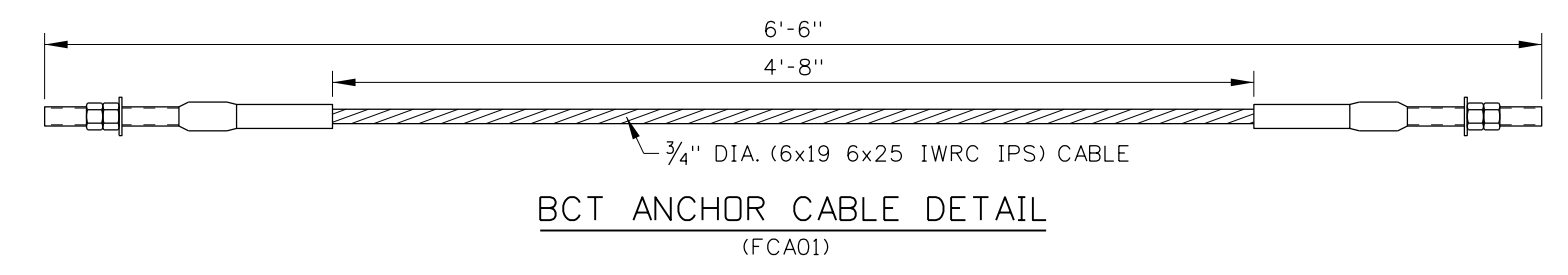
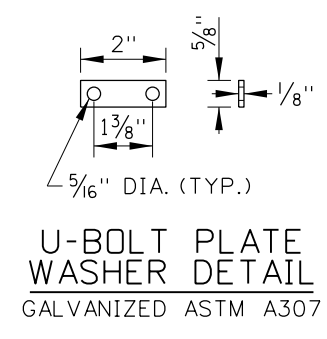
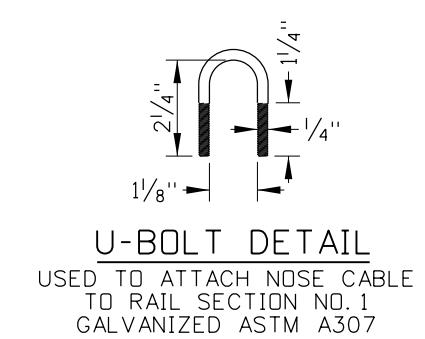
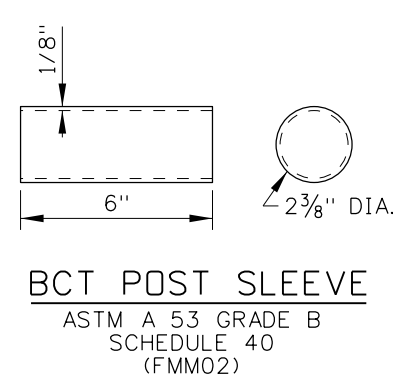
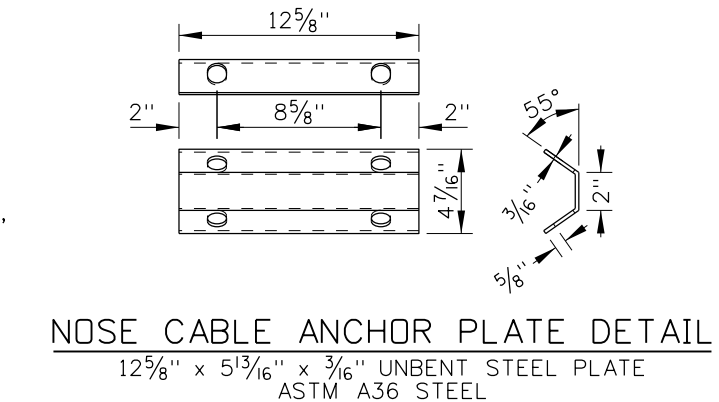
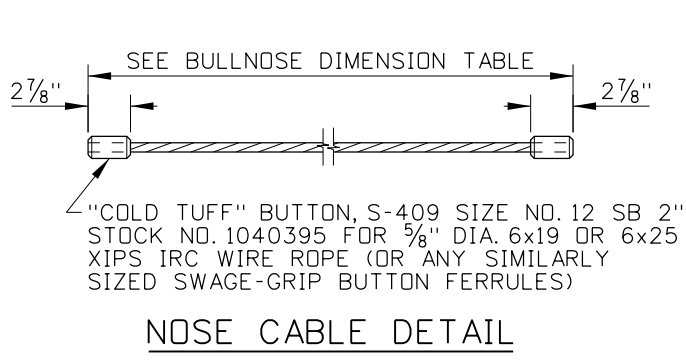
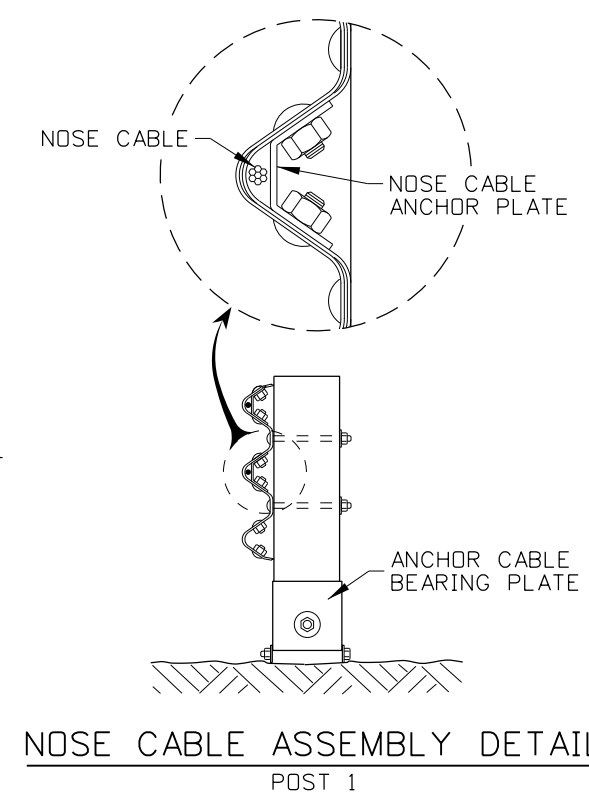
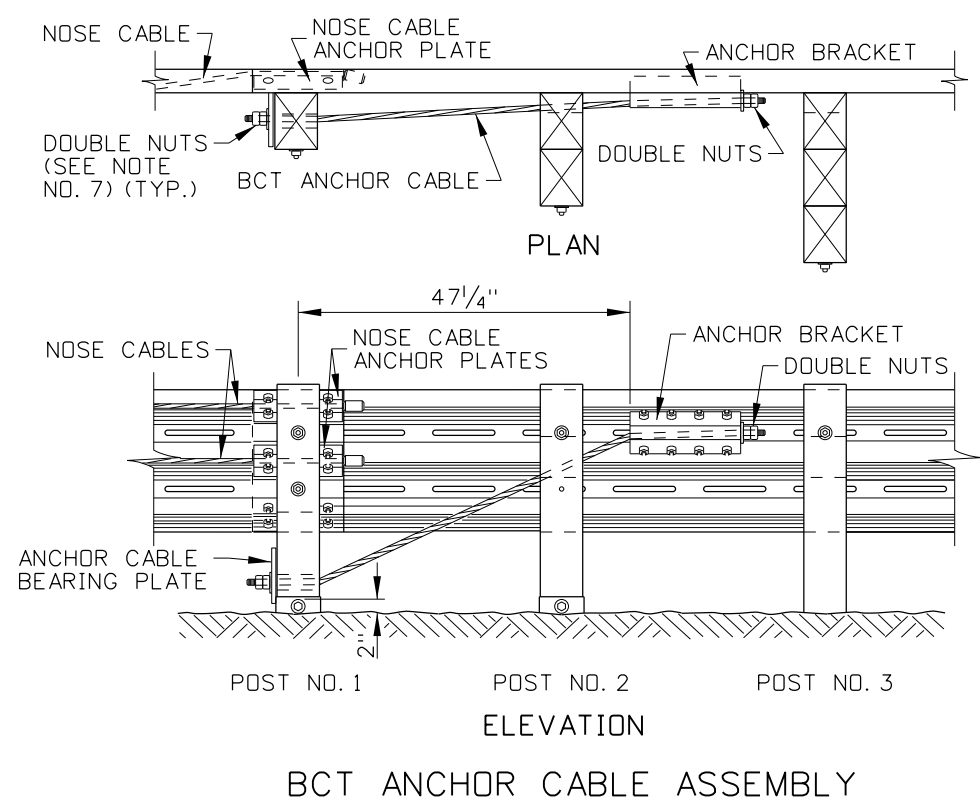

**ANCHOR BRACKET ASSEMBLY DETAIL**  
 BRACKET: 16"x12 1/2"x3/16" UNBENT STEEL PLATE  
 BEARING PLATE: 3"x2 3/4"x3/8"  
 ASTM A36 STEEL  
 (FPA01)

REVISIONS							
NO.	DATE	BY	NO.	DATE	BY	NO.	DATE
1	06-02	MSM	6	09-15	RDL		
2	10-03	MSM					
3	12-04	MSM					
4	05-06	MSM					
5	09-10	MGL					

SCALES SHOWN ARE FOR 11" X 17" PRINTS ONLY  
 CADD FILE NAME: 613-1\_1215.dgn  
 DRAWING DATE: NOVEMBER, 2001

**IDAHO TRANSPORTATION DEPARTMENT**

BOISE IDAHO

ORIGINAL SIGNED BY: TED E. MASON for  
 DESIGN/TRAFFIC SERVICES ENGINEER

STANDARD DRAWING  
**BULLNOSE CRASH CUSHION**

**English**  
 STANDARD DRAWING NO.  
**613-1**  
 SHEET 5 OF 7

ORIGINAL STORED AT: ITD, Headquarters 3311 West State Boise, Idaho

ORIGINAL SIGNED BY: RYAN D. LANCASTER  
 DATE ORIGINAL SIGNED: DECEMBER 8, 2015

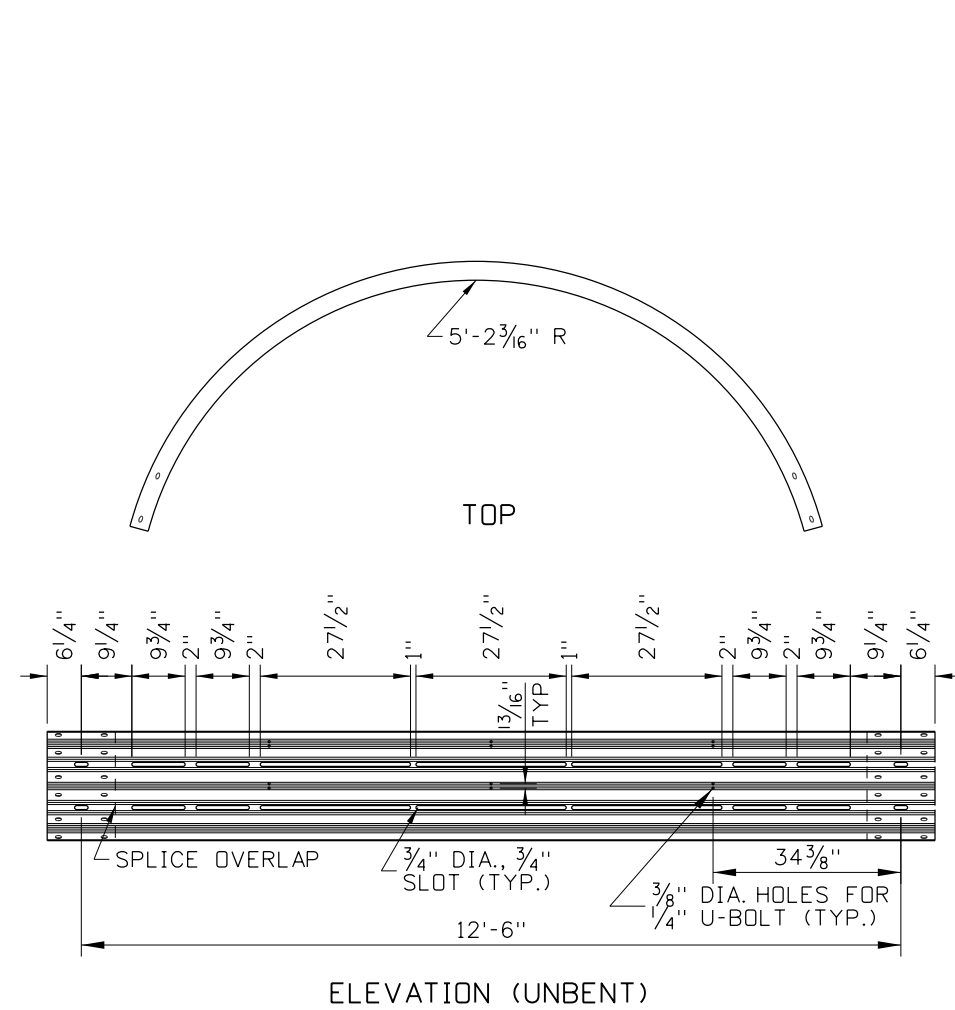

RAIL SECTION NO. 1  
 SYMMETRICAL DESIGN 1  
 ASYMMETRICAL DESIGNS 1 & 2  
 (RTM07a)

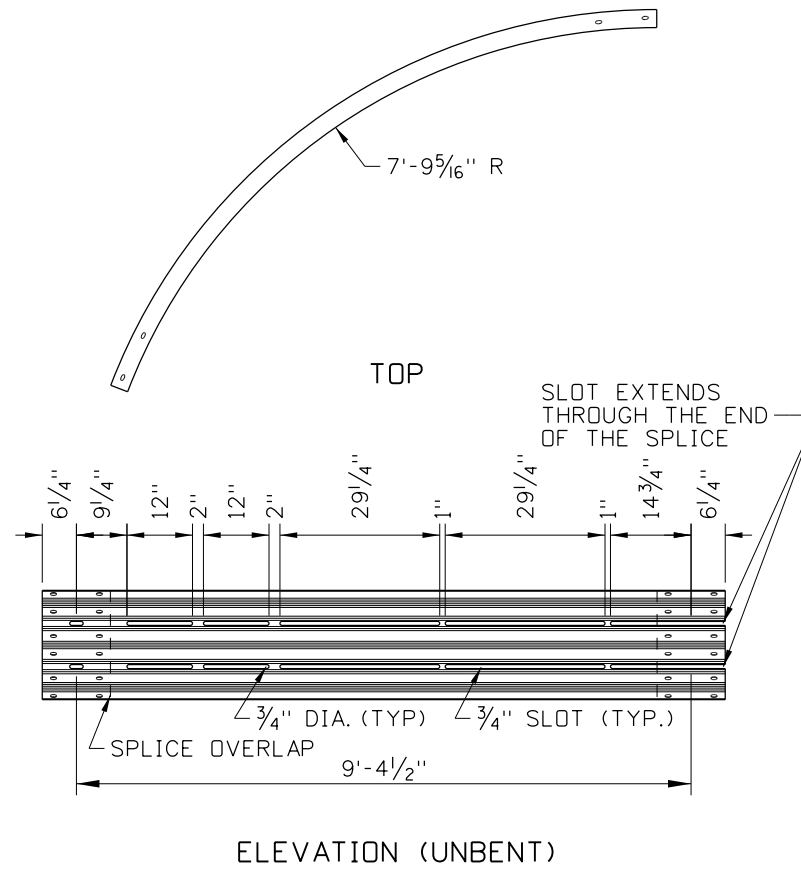

RAIL SECTION NO. 1  
 SYMMETRICAL DESIGN 2  
 (2 PIECES)

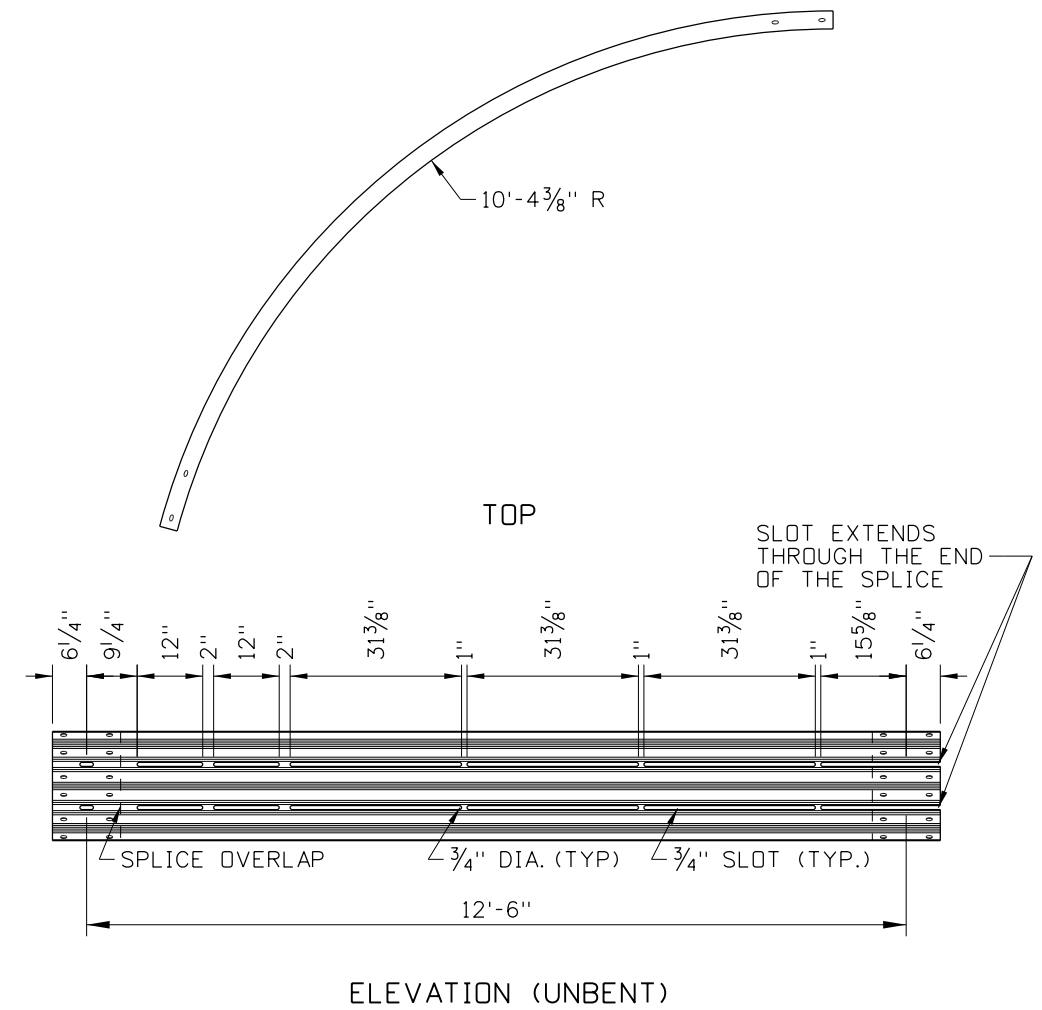

RAIL SECTION NO. 1  
 SYMMETRICAL DESIGN 3  
 (2 PIECES)

REVISIONS								
NO.	DATE	BY	NO.	DATE	BY	NO.	DATE	BY
1	06-02	MSM	6	09-15	RDL			
2	10-03	MSM						
3	12-04	MSM						
4	05-06	MSM						
5	09-10	MGL						

SCALES SHOWN  
 ARE FOR 11" X 17"  
 PRINTS ONLY

CADD FILE NAME:  
 613-1\_1215.dgn

DRAWING DATE:  
 NOVEMBER, 2001

**IDAHO  
 TRANSPORTATION  
 DEPARTMENT**



BOISE IDAHO

ORIGINAL SIGNED BY: TED E. MASON *for*  
 DESIGN/TRAFFIC SERVICES ENGINEER

STANDARD DRAWING  
**BULLNOSE CRASH CUSHION**

**English**  
 STANDARD DRAWING NO.  
**613-1**  
 SHEET 6 OF 7

ORIGINAL STORED  
 AT: ITD,  
 Headquarters  
 3311 West State  
 Boise, Idaho

ORIGINAL SIGNED BY:  
 RYAN D. LANCASTER  
 DATE ORIGINAL SIGNED:  
 DECEMBER 8, 2015

## DEFINITIONS

BCT POST - BREAKAWAY CABLE TERMINAL POST - A NON-PROPRIETARY WOOD POST USED IN GUARDRAIL ANCHORS.

CRT POST - CONTROLLED-RELEASE TERMINAL POST - A NON-PROPRIETARY, WEAKENED WOOD POST.

UBSP - UNIVERSAL BREAKAWAY STEEL POST - A NON-PROPRIETARY FRACTURING-BOLT STEEL POST.

TASK FORCE 13 - A JOINT AASHTO, AGC, AND ARTBA SUBCOMMITTEE ON NEW HIGHWAY MATERIALS AND TECHNOLOGIES. THE TASK FORCE ASSIGNS COMPONENT AND SYSTEM NUMBERS, AND MAINTAINS A GUIDE TO STANDARDIZED HIGHWAY BARRIER HARDWARE.

## NOTES

1. THE BULLNOSE CRASH CUSHION IS TYPICALLY USED TO SHIELD NARROW MEDIAN HAZARDS SUCH AS BRIDGE PIERS OR OVERHEAD SIGNS, TO SHIELD THE GAP BETWEEN TWIN BRIDGES, AND FOR GORE AREA PROTECTION.
2. SYMMETRICAL OR ASYMMETRICAL DESIGNS MAY BE USED.
3. EITHER THE WOOD OR THE STEEL POST OPTION MAY BE CHOSEN. DO NOT MIX WOOD AND STEEL POSTS (POST NOS. 1 AND 2 ARE WOOD IN BOTH THE WOOD AND STEEL POST OPTIONS).
4. ENSURE THAT GRADING UNDER, AROUND, AND IN FRONT OF THE BULLNOSE CRASH CUSHION IS 10:1 OR FLATTER. ENSURE THAT THE GRADING BEHIND THE NOSE OF THE CRASH CUSHION IS 10:1 OR FLATTER UP TO AT LEAST POST NO. 9.
5. POST NOS. 1 THROUGH 7 ARE SPACED AT 3'-1 1/2" INTERVALS. POSTS BEYOND POST NO. 7 ARE SPACED AT 6'-3" INTERVALS.
6. QUANTITIES SHOWN IN THE BULLNOSE CRASH CUSHION HARDWARE COMPONENTS TABLE ARE FOR RAIL SECTION NOS. 1 THROUGH 3 AND THE FIRST TWO 2-SPACE THRIE-BEAM GUARDRAIL SECTIONS AND POST NOS. 1 THROUGH 10.
7. TORQUE THE OUTSIDE NUTS ON EACH END OF THE ANCHOR CABLE A MINIMUM OF 100 FT.-LBS. AGAINST THE INSIDE NUTS.
8. DRAWING NOT TO SCALE.

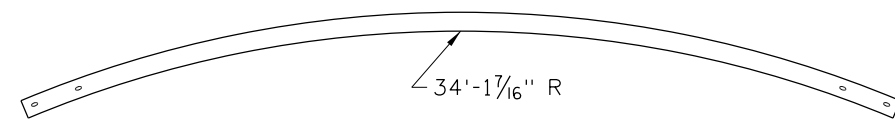

TOP  
(BENT SECTION - FOR SYMMETRICAL DESIGNS 1, 2, & 3  
AND ONE SIDE OF ASYMMETRICAL DESIGNS 1 & 2)



TOP  
(UNBENT SECTION - FOR ONE SIDE OF ASYMMETRICAL DESIGNS 1 & 2)

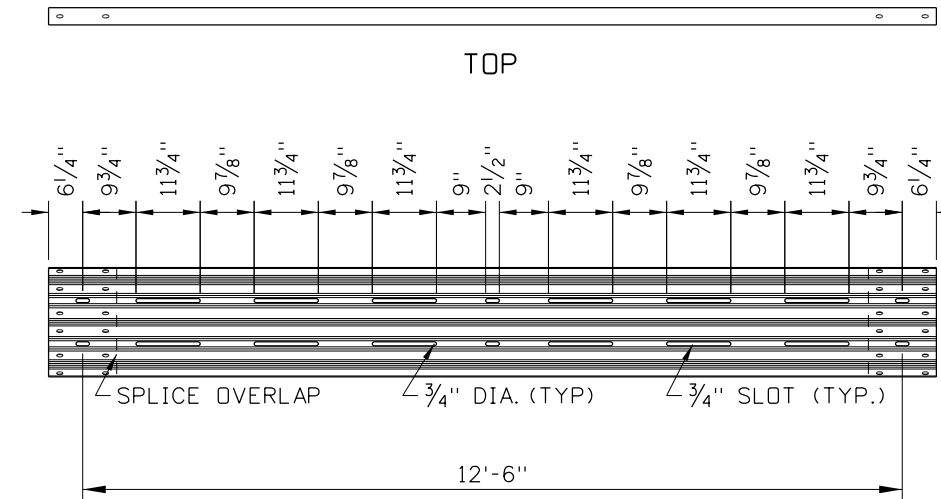

ELEVATION (UNBENT)

**RAIL SECTION NO. 3**  
SYMMETRICAL DESIGNS 1, 2, & 3  
ASYMMETRICAL DESIGNS 1 & 2  
(RTM07c)

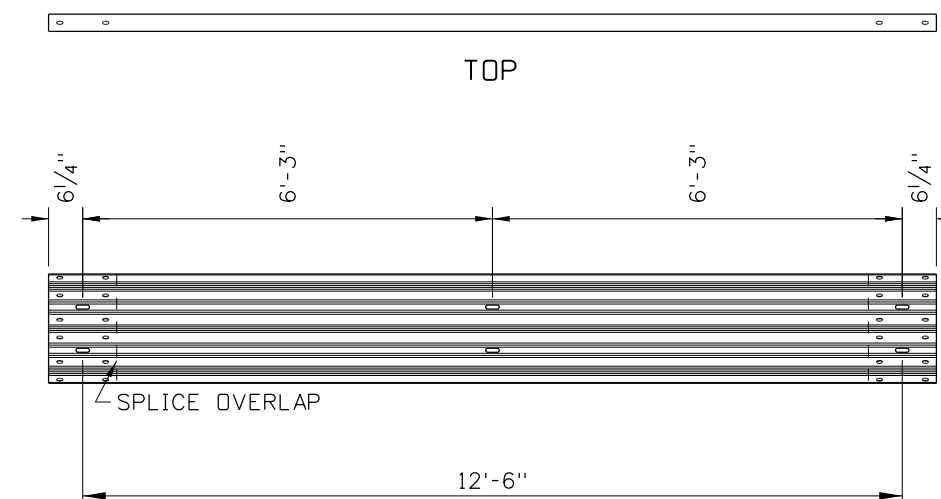

ELEVATION (UNBENT)

**2-SPACE THRIE-BEAM GUARDRAIL**  
SYMMETRICAL DESIGNS 1, 2, & 3  
ASYMMETRICAL DESIGNS 1 & 2  
(RTM02a)

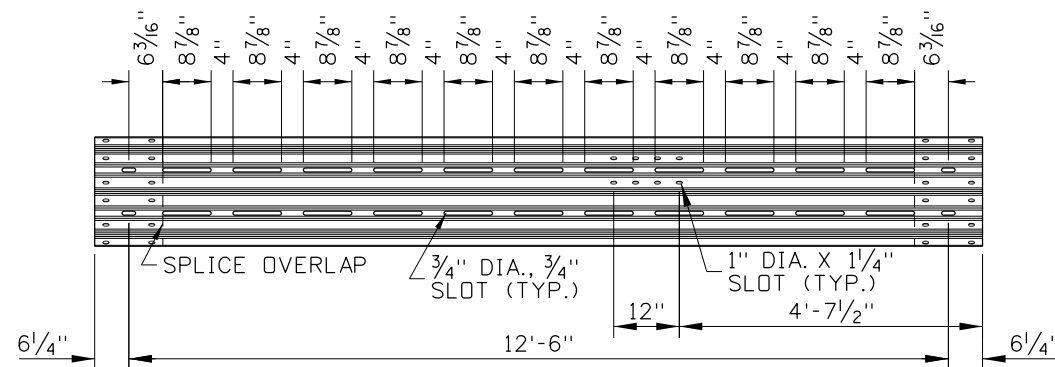

ELEVATION (UNBENT)

**RAIL SECTION NO. 2**  
SYMMETRICAL DESIGNS 1, 2, & 3  
ASYMMETRICAL DESIGNS 1 & 2  
(RTM07b)

### REVISIONS

NO.	DATE	BY	NO.	DATE	BY	NO.	DATE	BY
1	06-02	MSM	6	09-15	RDL			
2	10-03	MSM						
3	12-04	MSM						
4	05-06	MSM						
5	09-10	MGL						

SCALES SHOWN  
ARE FOR 11" X 17"  
PRINTS ONLY

CADD FILE NAME:  
613-1\_1215.dgn  
DRAWING DATE:  
NOVEMBER, 2001

**IDAHO  
TRANSPORTATION  
DEPARTMENT**



BOISE IDAHO

ORIGINAL SIGNED BY: TED E. MASON *for*  
DESIGN/TRAFFIC SERVICES ENGINEER

### STANDARD DRAWING

**BULLNOSE CRASH CUSHION**

ORIGINAL STORED  
AT: ITD,  
Headquarters  
3311 West State  
Boise, Idaho

**English**

STANDARD DRAWING NO.

**613-1**

SHEET 7 OF 7

ORIGINAL SIGNED BY:  
RYAN D. LANCASTER  
DATE ORIGINAL SIGNED:  
DECEMBER 8, 2015