

**DELINEATOR TYPES**

TYPE 9 NOT SHOWN  
(SEE NOTE NO. 9)

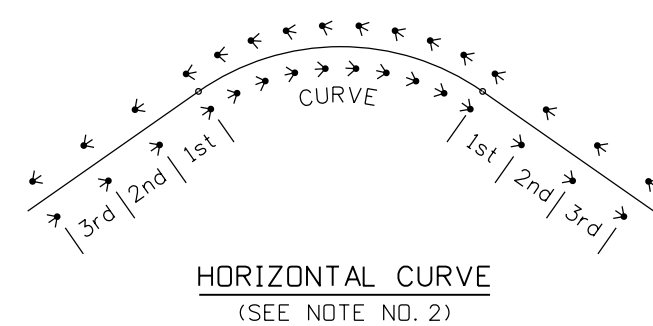
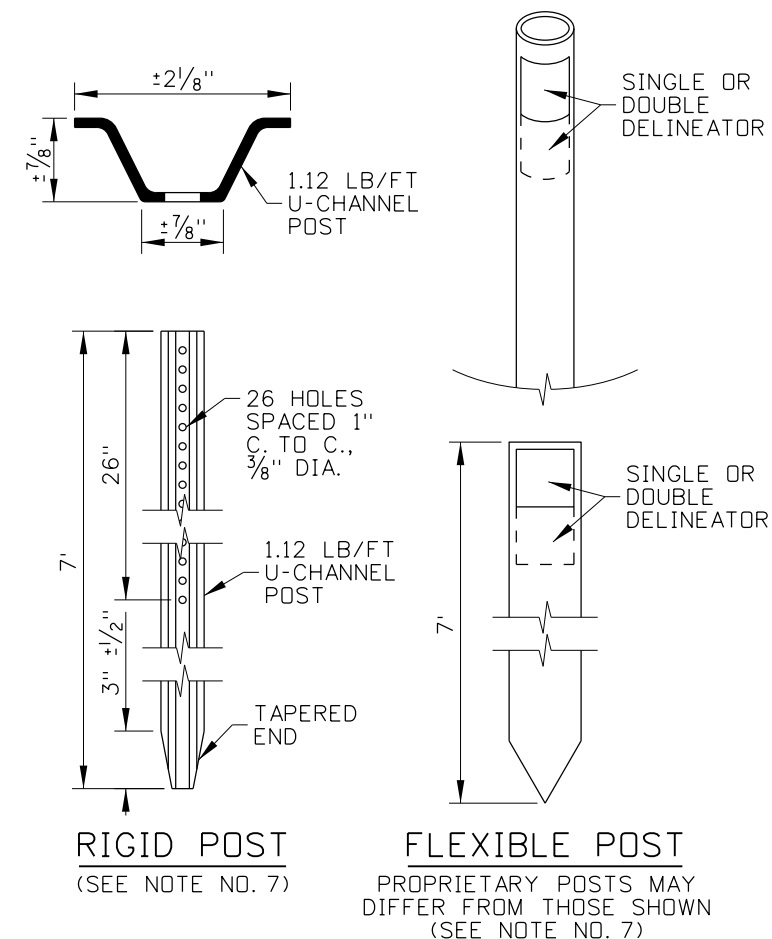

**HORIZONTAL CURVE**  
(SEE NOTE NO. 2)

RADIUS OF CURVE (FEET)	APPROXIMATE SPACING ON CURVE (FEET)	1st SPACE FROM CURVE (FEET)	2nd SPACE FROM CURVE (FEET)	3rd SPACE FROM CURVE (FEET)
50	20	40	60	120
115	25	50	75	150
180	35	70	105	210
250	40	80	120	240
300	50	100	150	300
400	55	110	165	300
500	65	130	195	300
600	70	140	210	300
700	75	150	225	300
800	80	160	240	300
900	85	170	255	300
1,000	90	180	270	300
1,500	115	230	300	300
2,500	150	300	300	300
5,000	210	300	300	300
10,000	300	300	300	300
> 10,000	528	528	528	528

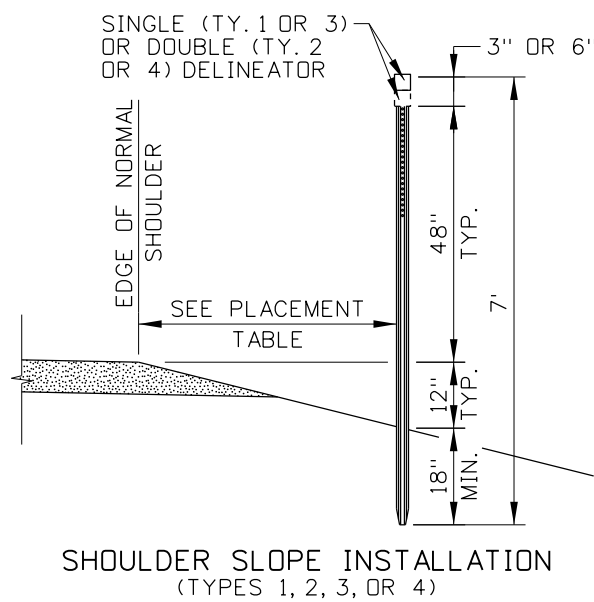

**SHOULDER SLOPE INSTALLATION**  
(TYPES 1, 2, 3, OR 4)

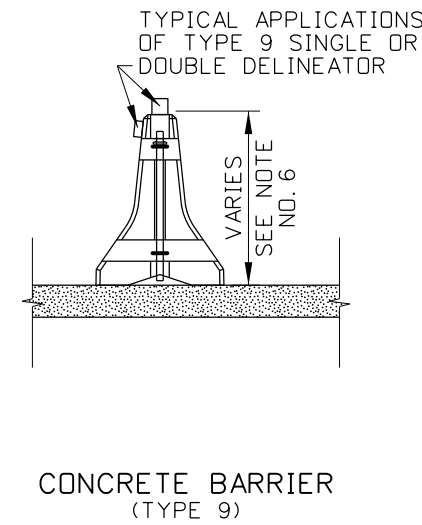

**CONCRETE BARRIER**  
(TYPE 9)

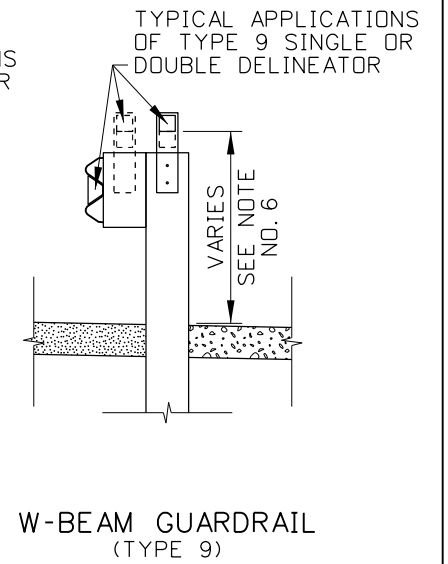

**W-BEAM GUARDRAIL**  
(TYPE 9)

**DELINEATOR INSTALLATIONS**

SHOULDER TYPE	OFFSET
2:1 SLOPE	2'
4:1 SLOPE	4'
6:1 OR FLATTER	6' TO 8'
CURB SECTION	6' TO 8'
GUARDRAIL OR CONCRETE BARRIER	VARIES

**NOTES**

1. MATCH THE DELINEATOR COLOR TO THE ADJACENT PAVEMENT MARKINGS. USE RED DELINEATORS ON TRUCK ESCAPE RAMPS OR ON THE REVERSE SIDE OF A DELINEATOR TO INDICATE TRAVEL IN THE WRONG DIRECTION ON DIVIDED OR ONE-WAY HIGHWAYS.
2. SPACE DELINEATORS 528 FEET (0.1 MI.) APART ON MAINLINE TANGENT SECTIONS. SPACE DELINEATORS ON CURVES IN ACCORDANCE WITH THE HORIZONTAL CURVE SPACING TABLE. SPACE DELINEATORS 100 FEET APART ON RAMP TANGENT SECTIONS. SPACE RED DELINEATORS ON TRUCK ESCAPE RAMPS AT 50 FOOT INTERVALS.
3. DELINEATE ACCELERATION AND DECELERATION LANES WITH DOUBLE DELINEATORS SPACED AT 100 FOOT INTERVALS.
4. DELINEATE GUARDRAIL AND CONCRETE BARRIERS. SPACING MAY BE REDUCED ON GUARDRAIL AND CONCRETE BARRIER TO FORM A CONTINUOUS OR NEARLY CONTINUOUS "RIBBON" OF DELINEATION.
5. WHEN UNIFORM SPACING IS INTERRUPTED BY DRIVEWAYS, INTERSECTIONS, OR OTHER FEATURES, RELOCATE THE DELINEATOR IN EITHER DIRECTION FOR A DISTANCE NOT EXCEEDING ONE QUARTER OF THE UNIFORM SPACING. DELINEATORS STILL FALLING WITHIN SUCH FEATURES MAY BE ELIMINATED.
6. MEASURE DELINEATOR HEIGHT VERTICALLY FROM THE BOTTOM OF THE LOWEST REFLECTIVE DEVICE TO THE ELEVATION OF THE EDGE OF NORMAL SHOULDER. DELINEATORS ATTACHED TO GUARDRAIL, GUARDRAIL POSTS, OR CONCRETE BARRIER MAY BE INSTALLED LOWER THAN 48".
7. RIGID OR FLEXIBLE POSTS MAY BE USED FOR TYPES 1, 2, 3, AND 4. PROJECT PLANS MAY INDICATE WHICH POST TYPE TO USE.
8. ON GUARDRAIL AND CONCRETE BARRIERS, USE TYPE 9 DELINEATORS OR TYPE 1, 2, 3, OR 4 DELINEATORS BEHIND THE BARRIER.
9. TYPE 9 DELINEATORS VARY IN SHAPE AND MAY BE ATTACHED TO THE TOP OR SIDE OF W-BEAM GUARDRAIL, GUARDRAIL POSTS, OR CONCRETE BARRIER. IF "BUTTERFLY" STYLE GUARDRAIL DELINEATORS ARE USED, ENSURE THAT THE DELINEATORS ARE PLASTIC.
10. DRAWINGS NOT TO SCALE.

ORIGINAL STORED AT: ITD, Headquarters 3311 West State Boise, Idaho

ORIGINAL SIGNED BY: RYAN D. LANCASTER  
DATE ORIGINAL SIGNED: AUGUST 22, 2018

NO.	DATE	BY	NO.	DATE	BY	NO.	DATE	BY
1	06-05	MSM	6	05-18	RDL			
2	11-11	TEM						
3	04-14	RDL						
4	03-15	PJF						
5	05-16	RDL						

SCALES SHOWN ARE FOR 11" X 17" PRINTS ONLY  
CADD FILE NAME: 617-1\_0818.dgn  
DRAWING DATE: DECEMBER, 2002

**IDAHO TRANSPORTATION DEPARTMENT**

BOISE IDAHO

ORIGINAL SIGNED BY: KEVIN SABLAN  
DESIGN/TRAFFIC SERVICES ENGINEER

STANDARD DRAWING  
**DELINEATORS**

**English**  
STANDARD DRAWING NO.  
**617-1**  
SHEET 1 OF 1