

**TYPE A ASSEMBLY**  
STEEL TUBE POST

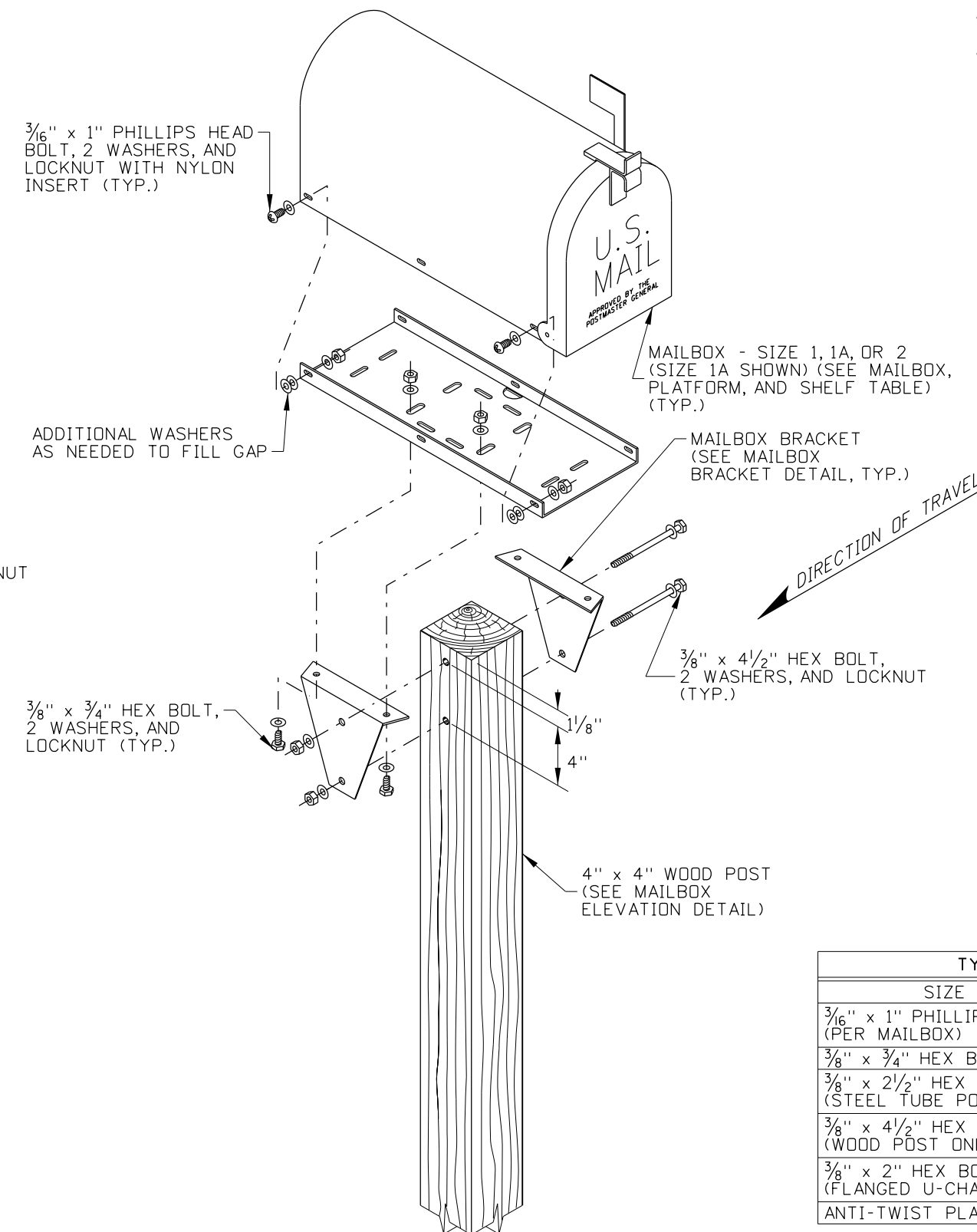

**TYPE A ASSEMBLY**  
WOOD POST

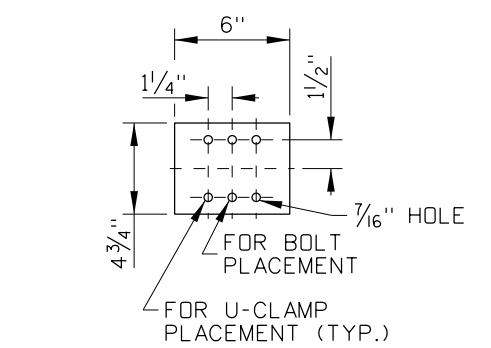
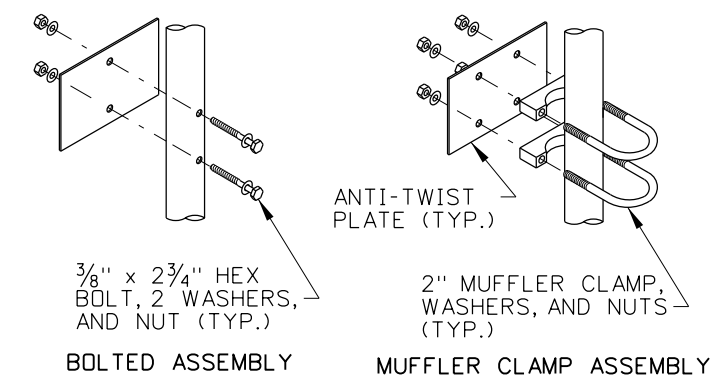

**ANTI-TWIST PLATE DETAIL**

TYPE A ASSEMBLY FASTENERS TABLE			
SIZE & TYPE	QUANTITY	WASHERS	LOCKNUTS
3/16" x 1" PHILLIPS HEAD BOLTS (PER MAILBOX)	4 MIN.	8 MIN.	4 MIN.
3/8" x 3/4" HEX BOLT (BRACKET)	4	8	4
3/8" x 2 1/2" HEX BOLT (STEEL TUBE POST ONLY)	2	4	2
3/8" x 4 1/2" HEX BOLT (WOOD POST ONLY)	2	4	2
3/8" x 2" HEX BOLT (FLANGED U-CHANNEL POST ONLY)	2	4	2
ANTI-TWIST PLATE ASSEMBLY	SEE ANTI-TWIST PLATE DETAIL		

REVISIONS								
NO.	DATE	BY	NO.	DATE	BY	NO.	DATE	BY
1	7-92	MSM	6	7-10	MGL			
2	7-02	MSM	7	11-11	TEM			
3	7-05	MSM	8	01-13	RDL			
4	12-05	MSM						
5	10-08	JRV						

SCALES SHOWN ARE FOR 11" X 17" PRINTS ONLY  
 CADD FILE NAME: 634-1\_0113.dgn  
 DRAWING DATE: SEPTEMBER, 1993

**IDAHO TRANSPORTATION DEPARTMENT**



BOISE IDAHO

ORIGINAL SIGNED BY: LOREN THOMAS  
 HIGHWAYS PROGRAM OVERSIGHT ENGINEER

ORIGINAL SIGNED BY: TOM COLE  
 CHIEF ENGINEER

STANDARD DRAWING

**MAILBOXES**

REQUIRES SHEETS 2 OF 5, 3 OF 5, 4 OF 5, & 5 OF 5

ORIGINAL STORED AT: ITD, Headquarters 3311 West State Boise, Idaho

**English**

STANDARD DRAWING NO. **634-1**

SHEET 1 OF 5

ORIGINAL SIGNED BY: RYAN D. LANCASTER  
 DATE ORIGINAL SIGNED: JANUARY 31, 2013

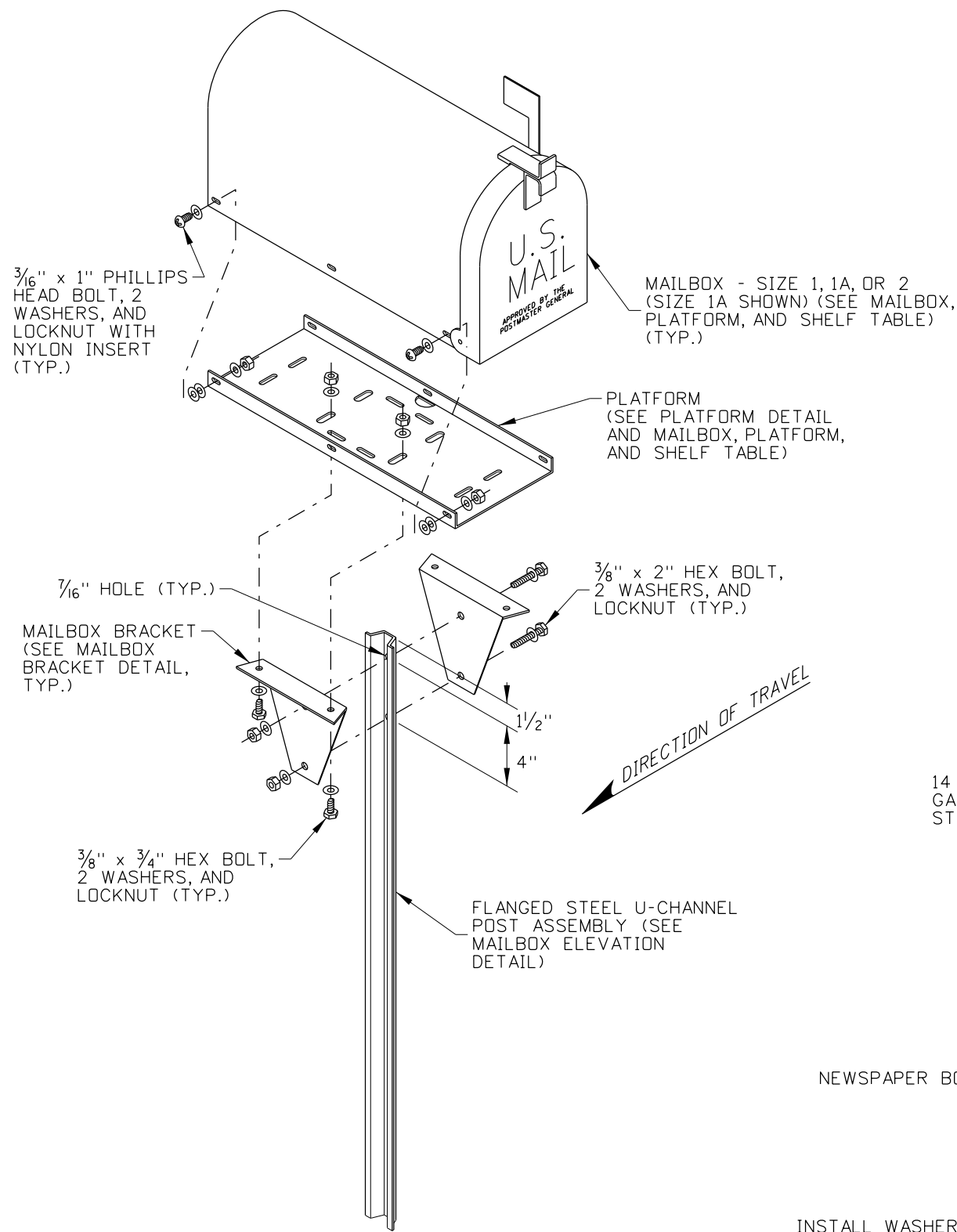

**TYPE A ASSEMBLY**  
FLANGED STEEL U-CHANNEL POST  
(2 LB/FT)

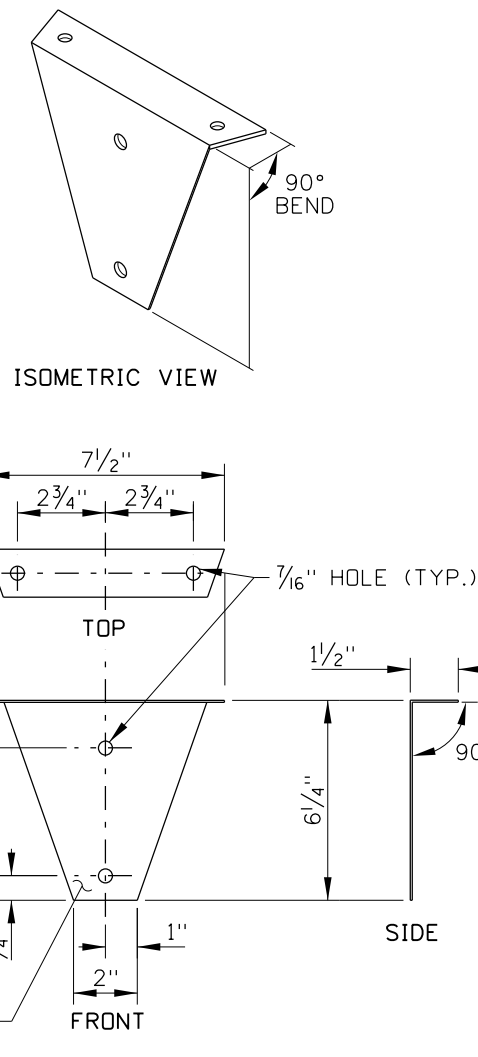

**MAILBOX BRACKET DETAIL**

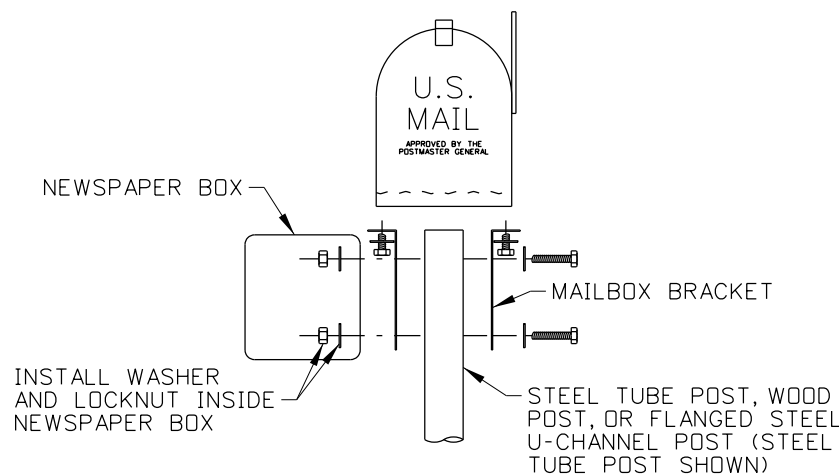

**NEWSPAPER BOX DETAIL**  
TYPE A ASSEMBLY

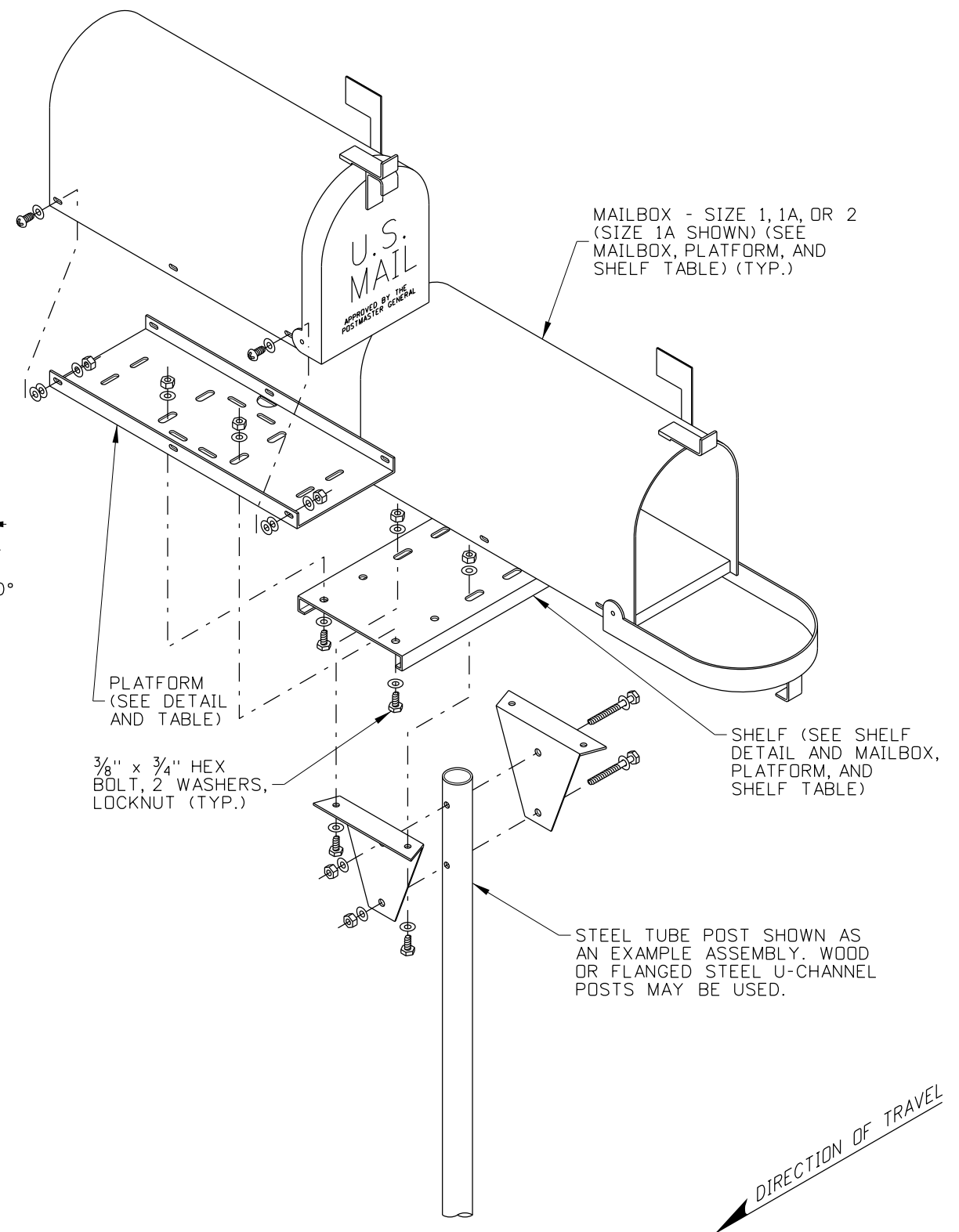

**TYPE A ASSEMBLY**  
DOUBLE MAILBOX ASSEMBLY

REVISIONS								
NO.	DATE	BY	NO.	DATE	BY	NO.	DATE	BY
1	7-92	MSM	6	7-10	MGL			
2	7-02	MSM	7	11-11	TEM			
3	7-05	MSM	8	01-13	RDL			
4	12-05	MSM						
5	10-08	JRV						

SCALES SHOWN ARE FOR 11" X 17" PRINTS ONLY

CADD FILE NAME: 634-1\_0113.dgn

DRAWING DATE: SEPTEMBER, 1993

**IDAHO TRANSPORTATION DEPARTMENT**



BOISE IDAHO

ORIGINAL SIGNED BY: LOREN THOMAS  
HIGHWAYS PROGRAM OVERSIGHT ENGINEER

ORIGINAL SIGNED BY: TOM COLE  
CHIEF ENGINEER

STANDARD DRAWING

**MAILBOXES**

REQUIRES SHEETS 1 OF 5, 3 OF 5, 4 OF 5, & 5 OF 5

ORIGINAL STORED AT: ITD, Headquarters 3311 West State Boise, Idaho

**English**

STANDARD DRAWING NO. **634-1**

SHEET 2 OF 5

ORIGINAL SIGNED BY: RYAN D. LANCASTER  
DATE ORIGINAL SIGNED: JANUARY 31, 2013

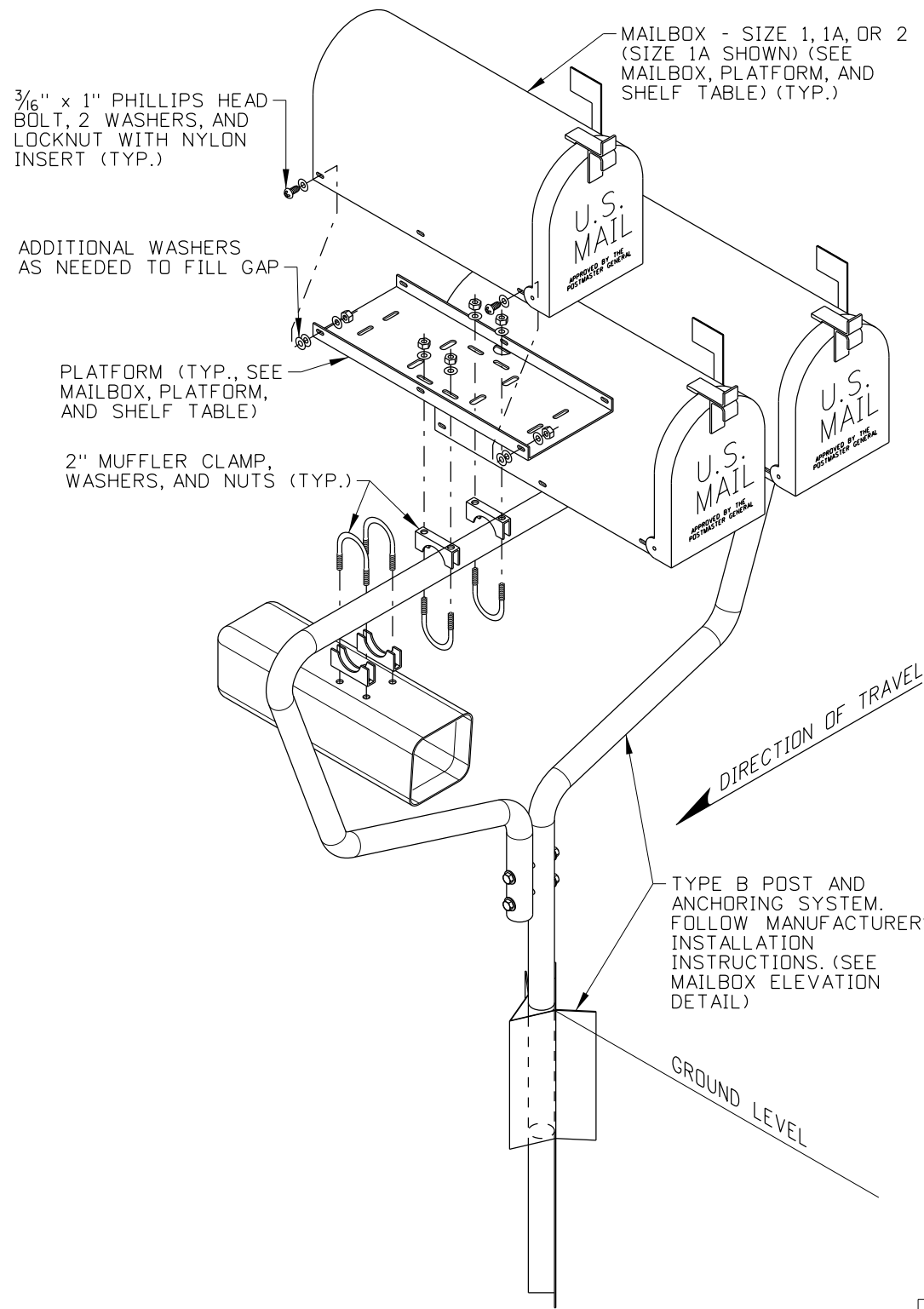

TYPE B ASSEMBLY

TYPE B ASSEMBLY FASTENERS TABLE			
SIZE & TYPE	QUANTITY	WASHERS	LOCKNUTS/NUTS
3/16" x 1" PHILLIPS HEAD BOLT (PER MAILBOX)	4 MIN.	8 MIN.	4 MIN.
2" MUFFLER CLAMP (PER MAILBOX)	2	4	4
2" MUFFLER CLAMP (PER NEWSPAPER BOX)	2	4	2
3/8" x 4 3/4" HEX BOLT (WOOD POST ONLY)	2	4	2
TYPE 2 POST AND ANCHORING SYSTEM	SEE MANUFACTURERS INSTALLATION INSTRUCTIONS		

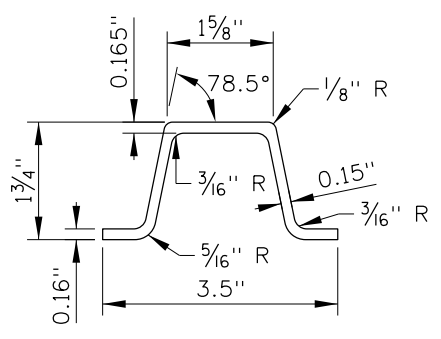
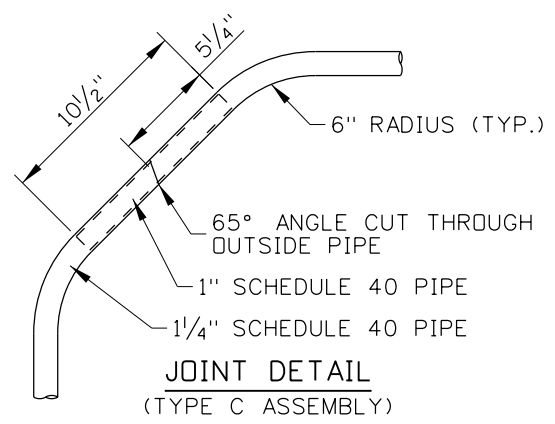

TYPE C ASSEMBLY FASTENERS TABLE			
SIZE & TYPE	QUANTITY	WASHERS	LOCKNUTS/NUTS
3/16" x 1" PHILLIPS HEAD BOLT	4 MIN.	8 MIN.	4 MIN.
1 1/4" MUFFLER CLAMP	2	4	4
5/16" x 2" HEX BOLT	3	6	3
1/4" U-CLAMP	2	0	4

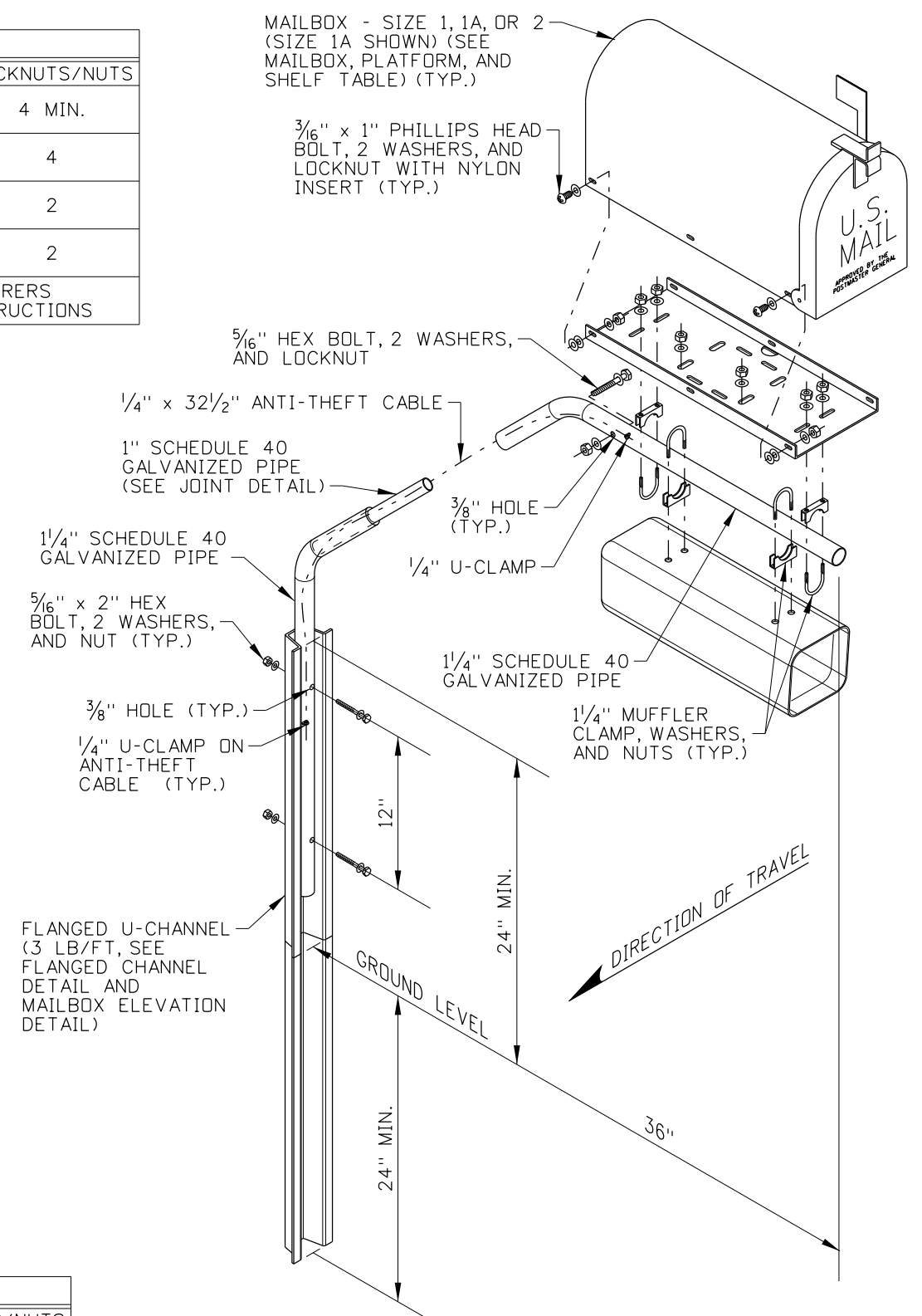

TYPE C ASSEMBLY

REVISIONS							
NO.	DATE	BY	NO.	DATE	BY	NO.	DATE
1	7-92	MSM	6	7-10	MGL		
2	7-02	MSM	7	11-11	TEM		
3	7-05	MSM	8	01-13	RDL		
4	12-05	MSM					
5	10-08	JRV					

SCALES SHOWN ARE FOR 11" X 17" PRINTS ONLY

CADD FILE NAME: 634-1\_0113.dgn

DRAWING DATE: SEPTEMBER, 1993

IDAHO TRANSPORTATION DEPARTMENT

BOISE IDAHO

ORIGINAL SIGNED BY: LOREN THOMAS  
HIGHWAYS PROGRAM OVERSIGHT ENGINEER

ORIGINAL SIGNED BY: TOM COLE  
CHIEF ENGINEER

STANDARD DRAWING

MAILBOXES

REQUIRES SHEETS 1 OF 5, 2 OF 5, 4 OF 5, & 5 OF 5

ORIGINAL STORED AT: ITD, Headquarters 3311 West State Boise, Idaho

English

STANDARD DRAWING NO. 634-1

SHEET 3 OF 5

ORIGINAL SIGNED BY: RYAN D. LANCASTER  
DATE ORIGINAL SIGNED: JANUARY 31, 2013

MAILBOX, PLATFORM, AND SHELF TABLE						
MAILBOX SIZE	MAILBOX DIMENSIONS			PLATFORM DIMENSION		SHELF DIM.
	L	W	H	L <sub>p</sub>	W <sub>p</sub>	L <sub>s</sub>
1	19"	6 1/2"	8 1/2"	17"	6"	15"
1-A	21"	8"	10 1/2"	19"	7 1/2"	16 1/2"
2	23 1/2"	11 1/2"	13 1/2"	21"	11"	20"

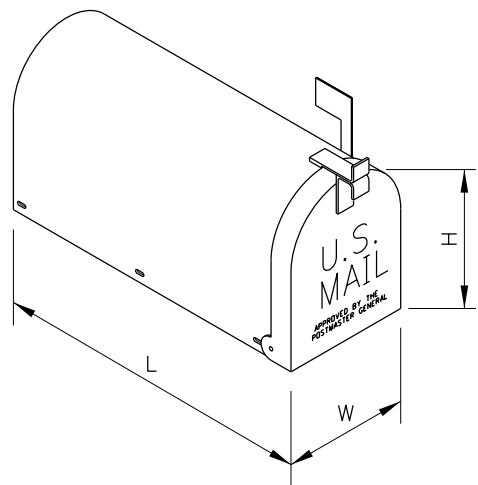

MAILBOX DIMENSIONS

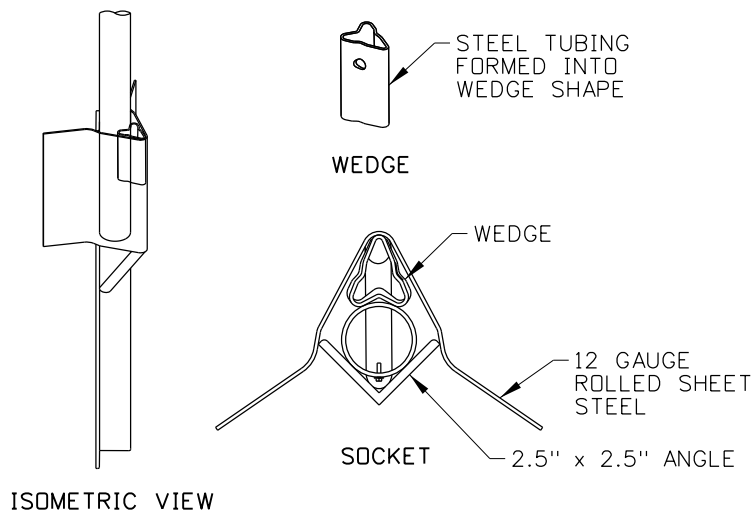

SOCKET AND WEDGE MAILBOX SUPPORT SYSTEM DETAIL

FOR USE WITH TYPE B ASSEMBLY  
MAY BE USED WITH TYPE A - STEEL TUBE POST ASSEMBLY  
(SEE MANUFACTURER'S INSTALLATION INSTRUCTIONS)

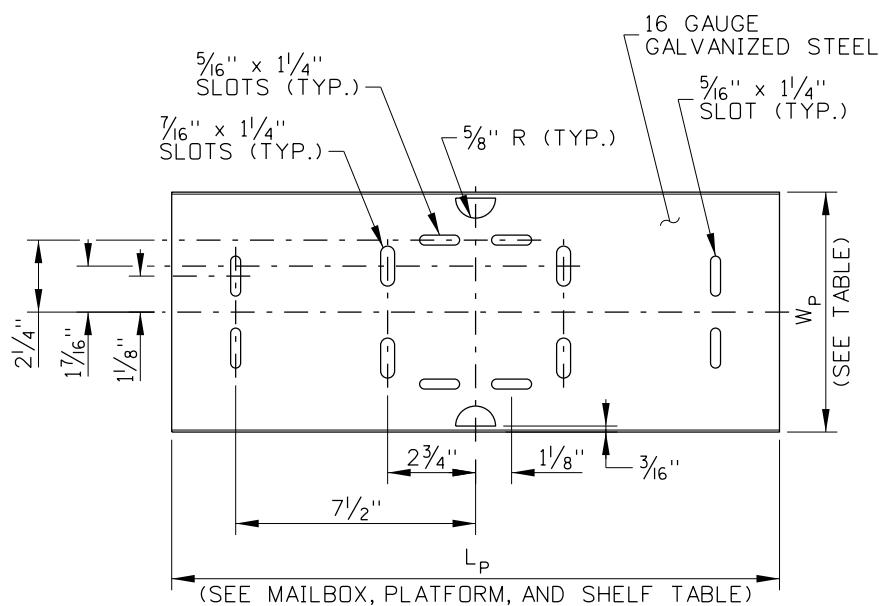

TOP

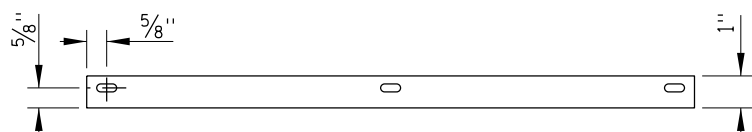

SIDE

PLATFORM DETAIL  
(ONE-PIECE)

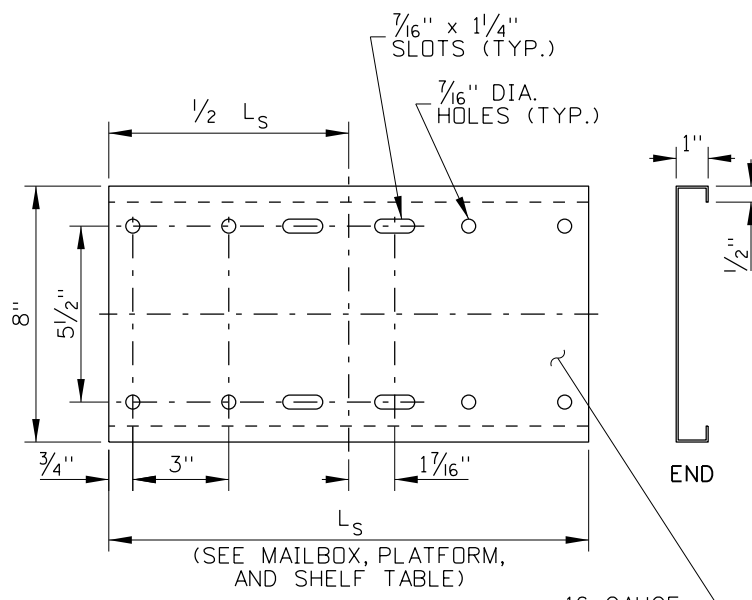

TOP

SHELF DETAIL  
(FOR TYPE A DOUBLE MAILBOX ASSEMBLIES)

NOTES

1. CONSTRUCT MAILBOX ASSEMBLIES IN ACCORDANCE WITH SECTION 634 - MAILBOX OF THE STANDARD SPECIFICATIONS FOR HIGHWAY CONSTRUCTION.
2. SEE STANDARD DRAWING H-4-B FOR MAILBOX PLACEMENT.
3. INSTALL THE MAILBOXES AND ASSEMBLIES WITH THE FASTENERS SHOWN IN THE ASSEMBLY FASTENER TABLES. SOME PLATFORM SLOTS AND HOLES MAY REMAIN UNUSED.
4. CENTER THE MAILBOX ON THE PLATFORM AND ENSURE THAT THE MAILBOX DOOR OPENS. SPACING OF MAILBOX MOUNTING HOLES MAY VARY BETWEEN MANUFACTURERS AND ADDITIONAL HOLES MAY BE DRILLED IN THE MAILBOX, PLATFORM, OR BOTH TO ATTACH THE MAILBOX TO THE PLATFORM.
5. COMMERCIALY AVAILABLE MAILBOXES AND MAILBOX ASSEMBLIES MAY BE SUBSTITUTED FOR THOSE SHOWN IF THEY MEET THE REQUIREMENTS OF THE U.S. POSTMASTER GENERAL AND HAVE SUCCESSFULLY PASSED THE TESTING REQUIREMENTS OF MASH OR NCHRP 350. ADJUSTABLE PLATFORM ALTERNATIVES AND THE SOCKET AND WEDGE MAILBOX SUPPORT SYSTEM ARE EXAMPLES OF COMMERCIALY AVAILABLE PROPRIETARY SYSTEMS THAT MAY BE ACCEPTABLE ALTERNATIVES. OBTAIN THE ENGINEER'S APPROVAL BEFORE INSTALLING ALTERNATIVE MAILBOXES OR ASSEMBLIES AND INSTALL IN ACCORDANCE WITH THE MANUFACTURERS INSTRUCTIONS.
6. USE AN ANTI-TWIST PLATE, SHOWN ON THE ANTI-TWIST PLATE DETAIL. A SOCKET AND WEDGE MAILBOX SUPPORT SYSTEM MAY BE USED IN LIEU OF AN ANTI-TWIST PLATE. IF THE SOCKET AND WEDGE SYSTEM IS USED, FOLLOW THE MANUFACTURER'S INSTALLATION INSTRUCTIONS.
7. THE TYPE C ASSEMBLY SHOULD BE USED IN HEAVY SNOW AREAS OR AREAS WHERE SNOW PLOW DAMAGE TO MAILBOXES HAS BEEN OBSERVED OR IS ANTICIPATED.
8. WHEN USED IN HEAVY SNOW AREAS, ONLY ONE MAILBOX IS RECOMMENDED FOR TYPE A ASSEMBLIES. THE TYPE A ASSEMBLY WITH WOOD POSTS IS RECOMMENDED FOR USE IN HEAVY SNOW AREAS. A SNOW SHIELD MAY BE INSTALLED AS SHOWN ON STANDARD DRAWING 634-2.
9. MAILBOX SIZES 1, 1A, AND 2, SHOWN IN THE MAILBOX, PLATFORM, AND SHELF TABLE MAY BE INSTALLED ON THE TYPE A DOUBLE MAILBOX ASSEMBLY IN ANY COMBINATION OF SIZES. WHEN MORE THAN ONE SIZE IS TO BE INSTALLED, USE THE SHELF SIZE FOR THE LARGER MAILBOX.
10. THE TYPE B ASSEMBLY IS A PROPRIETARY SYSTEM THAT MAY BE USED FOR THE INSTALLATION OF TWO OR MORE MAILBOXES. ON TYPE B MAILBOX ASSEMBLIES, INSTALL A MAXIMUM OF FIVE SIZE 1 MAILBOXES, FOUR SIZE 1A MAILBOXES, OR THREE SIZE 2 MAILBOXES. WHEN MORE THAN ONE SIZE IS TO BE INSTALLED, LIMIT THE NUMBER OF MAILBOXES TO THE MAXIMUM NUMBER FOR THE LARGEST SIZE USED.
11. DO NOT INSTALL THE MAILBOX ASSEMBLY IN A CONCRETE FOUNDATION. AN EXCEPTION MAY BE MADE FOR MASH OR NCHRP 350 APPROVED ALTERNATIVE MAILBOX ASSEMBLIES IN ACCORDANCE WITH THE MANUFACTURER'S INSTALLATION INSTRUCTIONS.
12. ENSURE THAT PLATFORM, SHELF, AND BRACKETS ARE GALVANIZED IN ACCORDANCE WITH AASHTO M 232.
13. IF USED, ATTACH THE NEWSPAPER BOX TO THE SUPPORT, DIRECTLY UNDER THE MAILBOX. ENSURE THAT NEWSPAPER BOXES DO NOT EXTEND BEYOND THE FRONT OF THE MAILBOX WHEN THE MAILBOX DOOR IS CLOSED. IN HEAVY SNOW AREAS, LOCATE THE NEWSPAPER BOX ON THE TRAILING SIDE OF THE MAILBOX POST. SEE THE NEWSPAPER BOX DETAIL FOR INSTALLATIONS ON TYPE A MAILBOX ASSEMBLIES.
14. ROUND OR GRIND THE CORNERS OF PLATFORMS, SHELVES, BRACKETS, OR OTHER HARDWARE THAT HAS SHARP PROTRUDING EDGES.
15. NOT TO SCALE.

REVISIONS								
NO.	DATE	BY	NO.	DATE	BY	NO.	DATE	BY
1	7-92	MSM	6	7-10	MGL			
2	7-02	MSM	7	11-11	TEM			
3	7-05	MSM	8	01-13	RDL			
4	12-05	MSM						
5	10-08	JRV						

SCALES SHOWN ARE FOR 11" X 17" PRINTS ONLY  
CADD FILE NAME: 634-1\_0113.dgn  
DRAWING DATE: SEPTEMBER, 1993

IDAHO TRANSPORTATION DEPARTMENT  
BOISE IDAHO

ORIGINAL SIGNED BY: LOREN THOMAS  
HIGHWAYS PROGRAM OVERSIGHT ENGINEER  
ORIGINAL SIGNED BY: TOM COLE  
CHIEF ENGINEER

STANDARD DRAWING  
MAILBOXES  
REQUIRES SHEETS 1 OF 5, 2 OF 5, 3 OF 5, & 5 OF 5

ORIGINAL STORED AT: ITD, Headquarters 3311 West State Boise, Idaho  
**English**  
STANDARD DRAWING NO.  
**634-1**  
SHEET 4 OF 5

ORIGINAL SIGNED BY: RYAN D. LANCASTER  
DATE ORIGINAL SIGNED: JANUARY 31, 2013

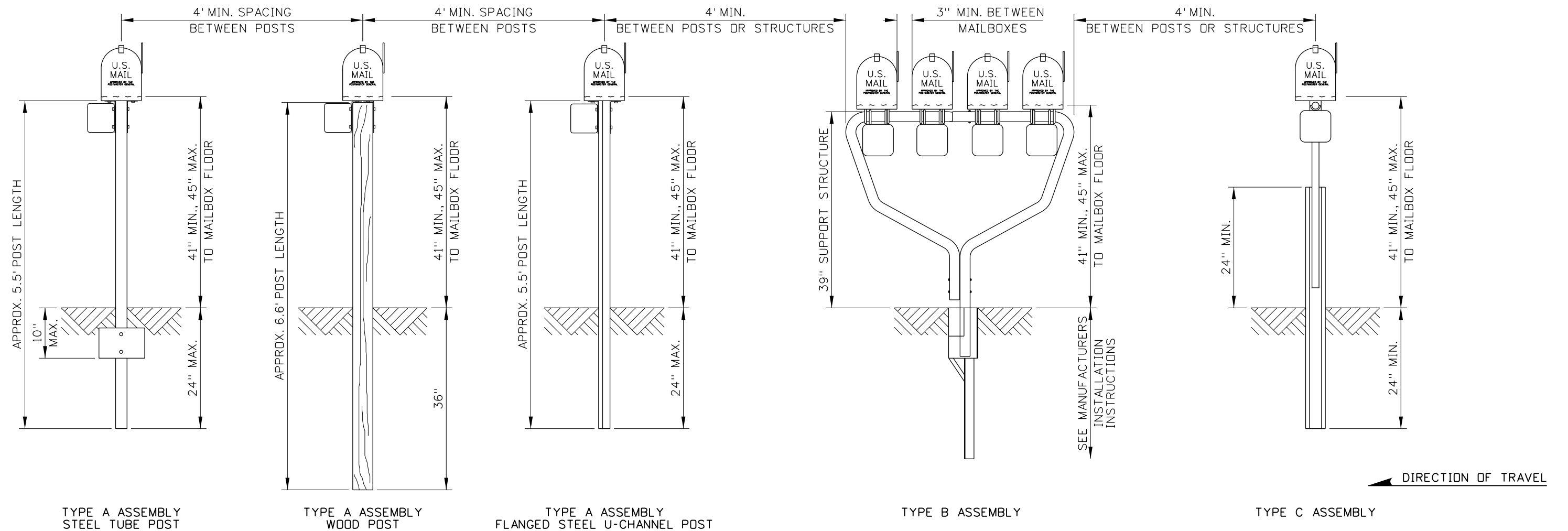

MAILBOX ELEVATION DETAIL

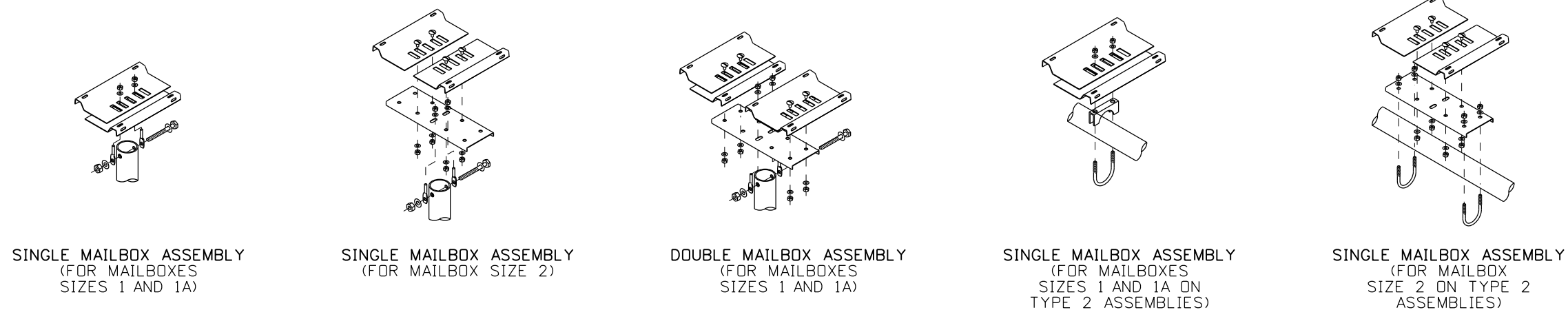

ADJUSTABLE PLATFORM ALTERNATIVES

REVISIONS								
NO.	DATE	BY	NO.	DATE	BY	NO.	DATE	BY
1	7-92	MSM	6	7-10	MGL			
2	7-02	MSM	7	11-11	TEM			
3	7-05	MSM	8	01-13	RDL			
4	12-05	MSM						
5	10-08	JRV						

SCALES SHOWN ARE FOR 11" X 17" PRINTS ONLY

CADD FILE NAME: 634-1\_0113.dgn

DRAWING DATE: SEPTEMBER, 1993

**IDAHO TRANSPORTATION DEPARTMENT**

BOISE IDAHO

ORIGINAL SIGNED BY: LOREN THOMAS  
HIGHWAYS PROGRAM OVERSIGHT ENGINEER

ORIGINAL SIGNED BY: TOM COLE  
CHIEF ENGINEER

STANDARD DRAWING

**MAILBOXES**

REQUIRES SHEETS 1 OF 5, 2 OF 5, 3 OF 5, & 4 OF 5

ORIGINAL STORED AT: ITD, Headquarters 3311 West State Boise, Idaho

**English**

STANDARD DRAWING NO. **634-1**

SHEET 5 OF 5

ORIGINAL SIGNED BY: RYAN D. LANCASTER  
DATE ORIGINAL SIGNED: JANUARY 31, 2013