

POSITION

- MAGNETIC ORIENTATION OF APPROACHING TRAVEL LANE.
N = NORTH, S = SOUTH, ETC.
- VEHICULAR MOVEMENT IN TRAVEL LANE: L = LEFT TURN; R = RIGHT TURN; NO ENTRY = THROUGH
- LANE DESIGNATION FOR EACH MOVEMENT: a-z IN ASCENDING ORDER, a BEING NEAREST THE CURB OR EDGE OF PAVEMENT.

- Na4
- Na3
- Na2
- Na1

- LOOP NUMBER IN EACH TRAVEL LANE: 1 - 4 IN ASCENDING ORDER, 1 BEING THE LOOP NEAREST THE STOP BAR.
- LOOP NUMBERING PROCEDURE EXAMPLE**
- | | | | |
|---|---|---|---|
| W | L | a | 3 |
| 1 | 2 | 3 | 4 |

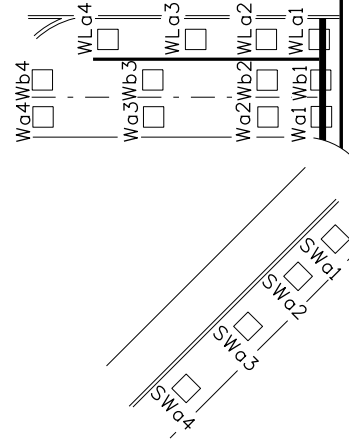

LOOP NUMBERING SYSTEM

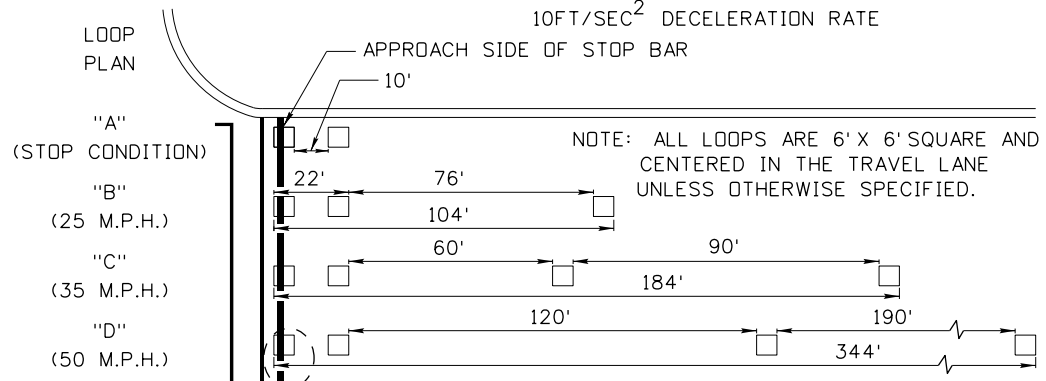
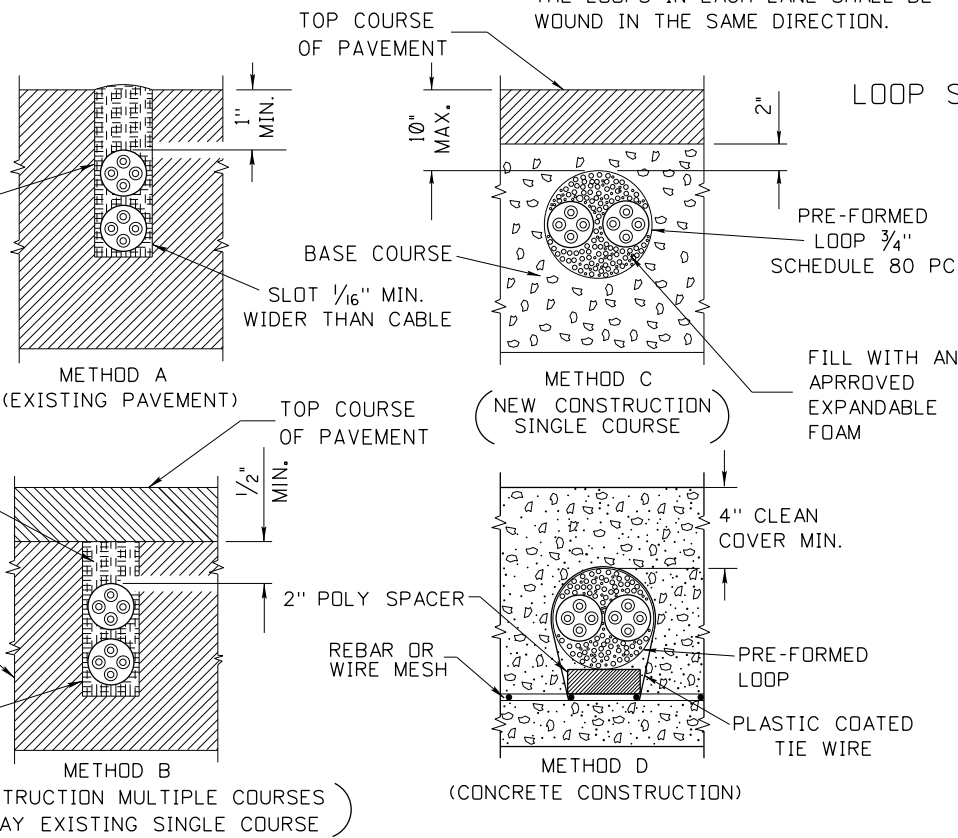

DETECTOR LOOP SPACING PLAN

THE 1' DIMENSION SHALL BE USED WITH/WITHOUT A CROSSWALK.

TEST CONDUCTOR: UNSPLICED TO THE CABINET

NOTE: SPLICING OF MULTIPLE LOOP CONDUCTORS AND CONNECTION TO THE LEAD-IN ALLOWED IN JCT. BOX ONLY. ALL LOOPS REQUIRE TWO TURNS OF FOUR CONDUCTOR CABLE.

THE LOOPS IN EACH LANE SHALL BE WOUND IN THE SAME DIRECTION.

LOOP SYSTEM AND JUNCTION BOX WIRING DIAGRAM

LOOP CONDUCTOR INSTALLATION

- NOTES:
- METHOD "C" MAY BE USED ONLY WITH PRE-FORMED LOOPS.
 - HYDRO CLEAN AND AIR DRY SLOTS AFTER CUTTING AND PRIOR TO CABLE INSTALLATION.
 - BED LOOP CONDUCTORS IN SEALANT FOR TOTAL ENCAPSULATION.
 - SEAT LOOP CONDUCTORS IN SLOT WITH A BLUNT INSTRUMENT.

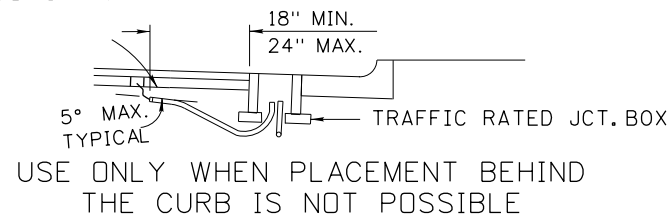

USE ONLY WHEN PLACEMENT BEHIND THE CURB IS NOT POSSIBLE

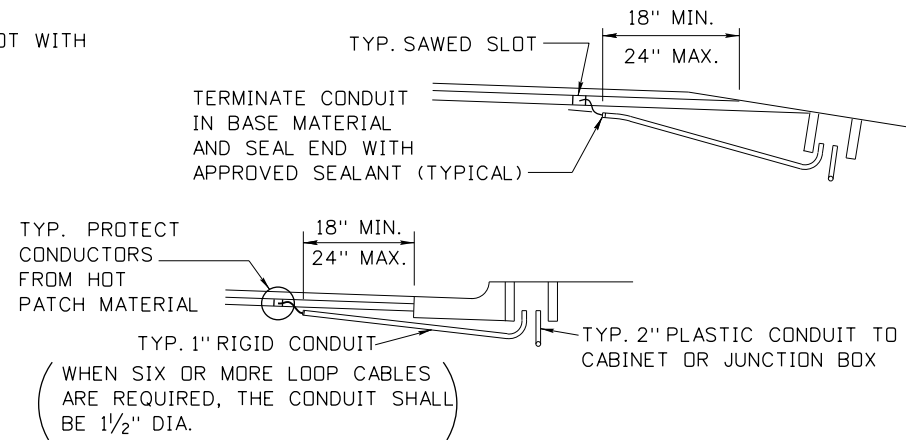

JUNCTION BOX AND CONDUIT LOCATION

NOTES:

- ALL CONDUCTOR SPLICES SHALL BE SOLDERED AND WATERPROOFED WITH AN APPROVED SPLICE KIT.
- THE FOIL SHIELD SHALL BE INSULATED TO PREVENT GROUNDING AT THE JUNCTION BOX.
- * SPLICE DUAL PURPOSE LOOPS TO THE RED AND GREEN CONDUCTORS.

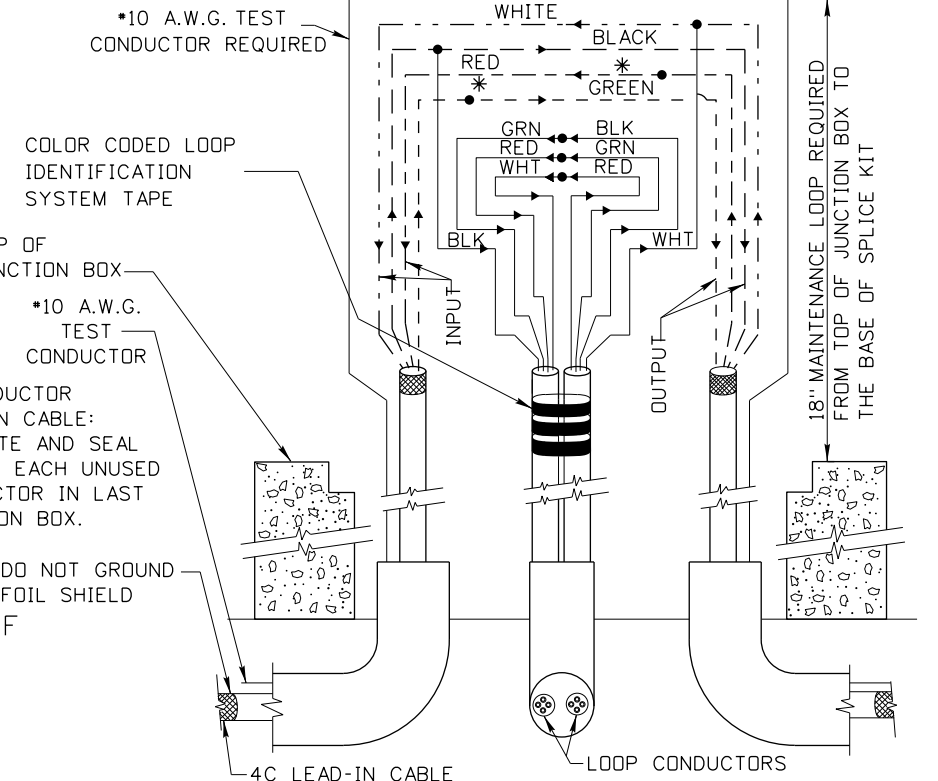

LOOP SPLICE DETAIL AT JUNCTION BOX

LANE NO.	TAPE COLOR
1	BLACK
2	WHITE
3	RED
4	GREEN
5	ORANGE
6	BLUE

IN ASCENDING ORDER - BLACK SHALL BE USED FOR THE LANE NEAREST THE CURB OR EDGE OF PAVEMENT.

EXAMPLE: CONDUCTORS FOR LOOP 1 LANE 1 REQUIRE 1 BAND OF BLACK TAPE.

CONDUCTORS FOR LOOP 3 LANE 4 REQUIRE 3 BANDS OF GREEN TAPE.

COLOR CODED LOOP IDENTIFICATION SYSTEM

ORIGINAL STORED AT: ITD, Headquarters 3311 West State Boise, Idaho

ORIGINAL SIGNED BY: CARL D. MAIN
DATE ORIGINAL SIGNED: JULY 12, 2010

REVISIONS							
NO.	DATE	BY	NO.	DATE	BY	NO.	DATE
1	12-93	HEB	6	08-08	NQB		
2	12-94	HEB	7	07-10	HEB		
3	03-96	HEB					
4	07-03	HEB					
5	08-06	HEB					

SCALES SHOWN ARE FOR 11" X 17" PRINTS ONLY

CADD FILE NAME: 656-10_0710.dgn

DRAWING DATE: DECEMBER, 1994

IDAHO TRANSPORTATION DEPARTMENT

BOISE IDAHO

ORIGINAL SIGNED BY: LOREN THOMAS
ASSISTANT CHIEF ENGINEER (DEVELOPMENT)

ORIGINAL SIGNED BY: TOM COLE
CHIEF ENGINEER

STANDARD DRAWING

LOOP DETECTORS

10FT/SEC² DECELERATION RATE

English

STANDARD DRAWING NO. **656-10**

SHEET 1 OF 1