

ELEVATION

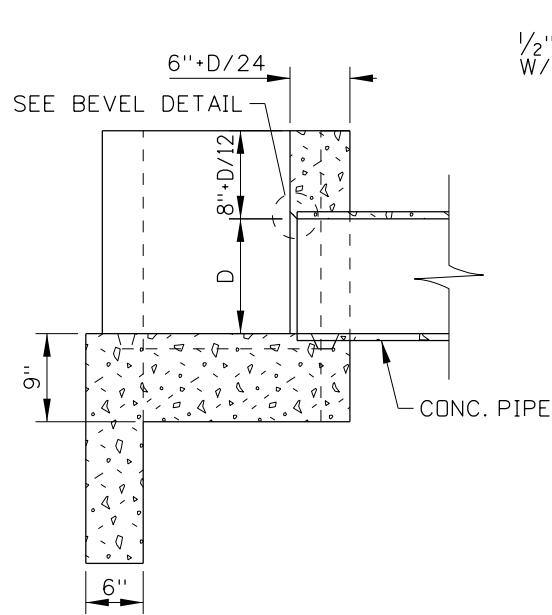

SECTION A-A

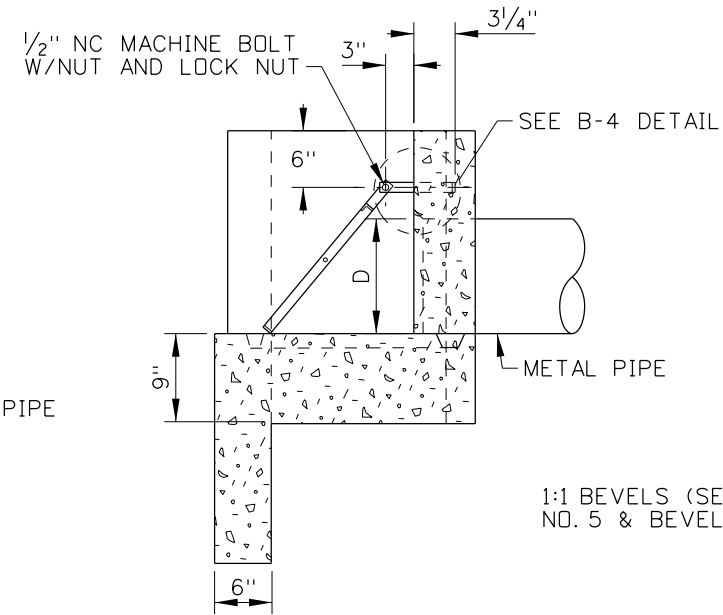

SECTION B-B

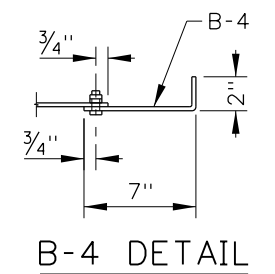

B-4 DETAIL

1:1 BEVELS (SEE NOTE NO. 5 & BEVEL DETAIL)

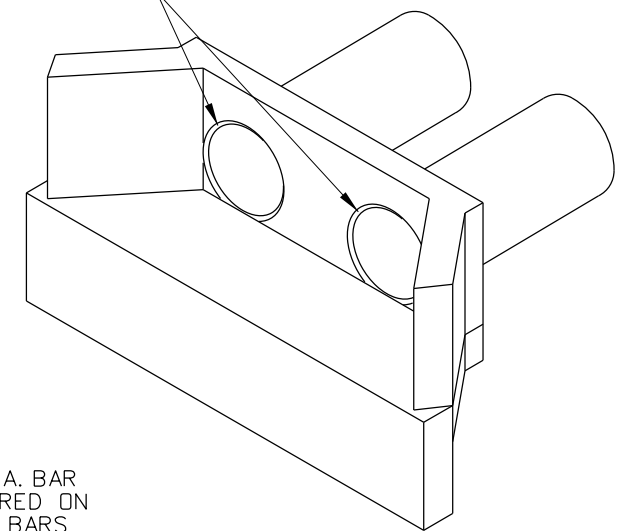

ISOMETRIC VIEW

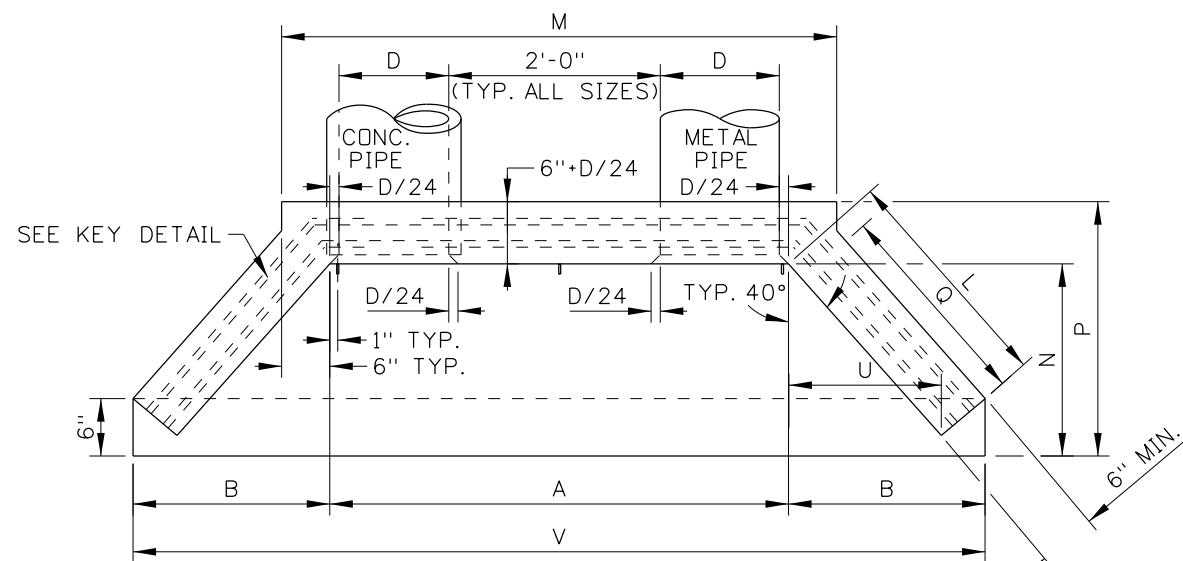

PLAN

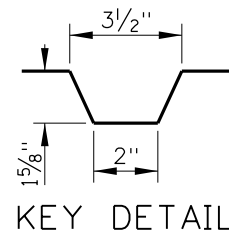

KEY DETAIL

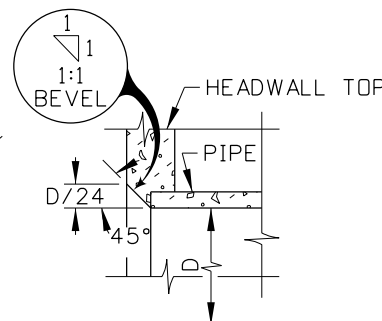

BEVEL DETAIL

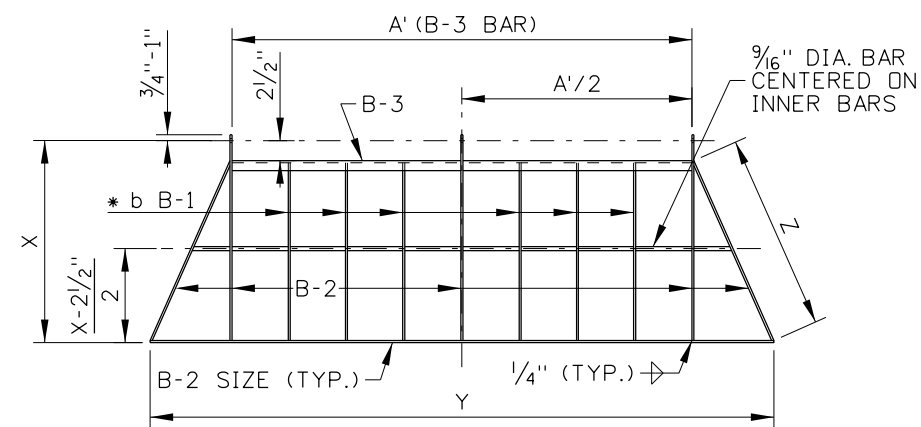

INLET GRATE DETAIL

* o BARS SHALL BE EQUALLY SPACED IN GRATE NOT TO EXCEED 8" CENTER TO CENTER OR LESS THAN 6" CENTER TO CENTER.

REVISIONS							
NO.	DATE	BY	NO.	DATE	BY	NO.	DATE
1	02-68		6	12-92	TMR		
2	09-68		7	10-01	MSM		
3	10-69		8	06-03	MSM		
4	04-90	GB	9	03-05	MSM		
5	03-92	MSM					

SCALES SHOWN ARE FOR 11" X 17" PRINTS ONLY
 CADD FILE NAME: d7_0305.dgn
 DRAWING DATE: MAY, 1964

IDAHO TRANSPORTATION DEPARTMENT
 BOISE IDAHO

ORIGINAL SIGNED BY: LOREN THOMAS
 ASSISTANT CHIEF ENGINEER (DEVELOPMENT)
 ORIGINAL SIGNED BY: STEVEN HUTCHINSON
 CHIEF ENGINEER

STANDARD DRAWING
CONCRETE HEADWALL FOR TWIN PIPE CULVERTS
 REQUIRES SHEET 2 OF 2

English
 STANDARD DRAWING NO. D-7
 SHEET 1 OF 2

ORIGINAL STORED AT: ITD, Headquarters 3311 West State Boise, Idaho

ORIGINAL SIGNED BY: MILDRED L. MILLER
 DATE ORIGINAL SIGNED: MARCH 4, 2005

METAL REINFORCEMENT TABLE			
MARK	LOCATION	BAR SIZE	SKETCH
F-1	FLOOR	NO. 4	
H-1A	HORIZ. IN TOP OF WING WALL & IN FLOOR BACKWALL	NO. 4	
H-1B	HORIZ. IN WING WALL BETWEEN H-1As' (PAIRS)	NO. 4	
H-2	VERT. IN BCKWL. WALL BETWEEN AROUND PIPE	NO. 4	
L-1	TOP & BOTOM OF INLET LIP IN FLOOR	NO. 4	
L-2	VERTICAL IN FLOOR, & INLET LIP	NO. 4	
W-1A	EACH SIDE OF PIPE IN BACKWALL, FLOOR, & INLET LIP	NO. 4	
W-1B	IN FLOOR, & INLET LIP, UNDER PIPES	NO. 4	
W-1C	IN FLOOR, & INLET LIP	NO. 4	
W-2	VERTICAL IN WING WALLS	NO. 4	

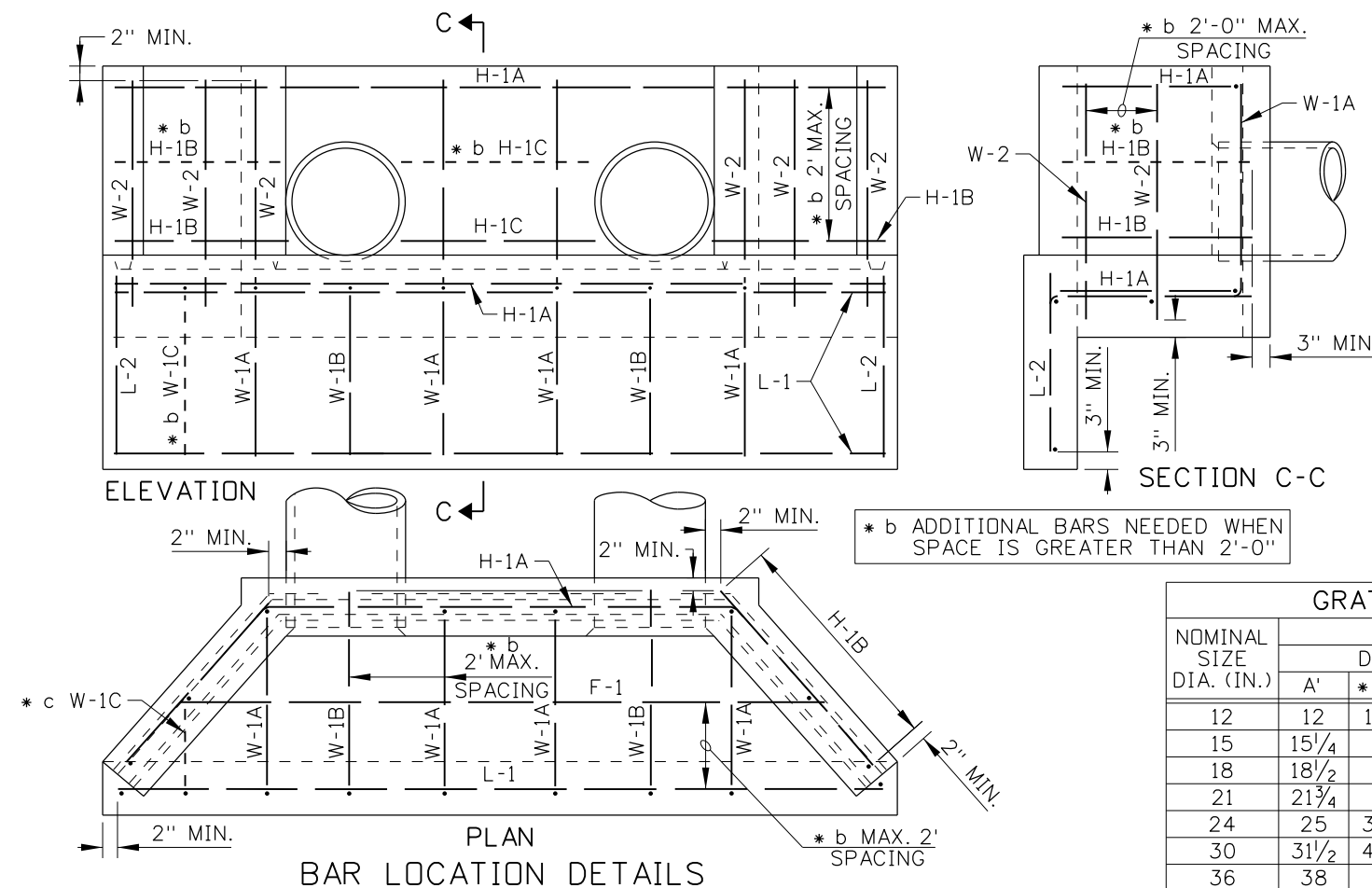

NOMINAL SIZE DIA. (IN.)	CONCRETE (C.Y.)			
	WING & BCKWL.	FLOOR	LIP	TOTAL
12	0.3	0.4	0.2	0.9
15	0.4	0.6	0.2	1.2
18	0.5	0.7	0.2	1.4
21	0.6	0.8	0.3	1.7
24	0.7	1.0	0.3	2.0
30	1.0	1.3	0.3	2.6
36	1.3	1.7	0.4	3.4
42	1.7	2.1	0.5	4.3

NOMINAL SIZE DIA. (IN.)	GRATE DIMENSION & MATERIALS TABLE							
	IN INCHES							
	DIMENSIONS				BAR SIZES			
	A'	* c X	Y	Z	B-1	B-2	B-3	B-4
12	12	19 1/4	29 1/2	18 7/8	1x1/4	1 1/4x1/4	1 1/4x1 1/4x1/4	1x1/4x9
15	15 1/4	24	39 1/2	24 3/4	1x1/4	1 1/4x1/4	1 1/4x1 1/4x1/4	1x1/4x9
18	18 1/2	28	46 1/2	29	1x1/4	1 1/4x1/4	1 1/4x1 1/4x1/4	1x1/4x9
21	21 3/4	33	55 3/4	35	1x1/4	1 1/4x1/4	1 1/4x1 1/4x1/4	1x1/4x9
24	25	37 1/2	66 1/2	40 5/8	1x1/4	1 1/4x1/4	1 1/4x1 1/4x1/4	1x1/4x9
30	31 1/2	46 3/4	81 1/2	50 7/8	1 1/4x1/4	1 1/2x1/4	1 1/2x1 1/2x1/4	1 1/2x1/4x9
36	38	56	98	61 1/8	1 1/2x1/4	1 3/4x1/4	1 3/4x1 3/4x1/4	1 3/4x1/4x9
42	44 1/2	65	116	72	1 3/4x1/4	2 1/4x3/8	2 1/4x2 1/2x3/8	2 1/4x3/8x9

NOMINAL SIZE DIA. (IN.)	HEADWALL DIMENSION TABLE										
	IN INCHES										
	D/24	A	B	H	L	M	N	P	Q	U	V
12	1/2	49	20 3/8	21	24 5/8	61	21	27 1/2	22 1/2	15 7/8	89 3/4
15	5/8	55 1/4	23 3/8	24 1/4	28 7/8	67 1/4	24 1/4	30 7/8	26 5/8	18 5/8	101 1/2
18	3/4	61 1/2	25 3/8	27 1/2	33 3/8	73 1/2	27 1/2	34 1/4	30 7/8	21 1/4	113 1/4
21	7/8	67 3/4	28 5/8	30 3/4	37 3/8	79 3/4	30 3/4	37 5/8	35 1/8	24	125
24	1	74	31 3/8	34	41 5/8	86	34	41	39 3/8	26 3/4	136 3/4
30	1 1/4	86 1/2	36 3/4	40 1/2	50 1/8	98 1/2	40 1/2	47 3/4	47 7/8	32 1/4	160
36	1 1/2	99	42 1/4	47	58 5/8	111	47	54 1/2	56 3/8	37 5/8	183 1/2
42	1 3/4	111 3/4	47 5/8	53 1/2	67 7/8	123 1/2	53 1/2	61 1/4	64 7/8	43 3/8	207

BAR	METAL REINFORCEMENT TABLE															
	NOMINAL PIPE SIZE DIAMETER (IN.)															
	12		15		18		21		24		30		36		42	
	NO.	LGTH.	NO.	LGTH.	NO.	LGTH.	NO.	LGTH.	NO.	LGTH.	NO.	LGTH.	NO.	LGTH.	NO.	LGTH.
F-1	1	71 7/8	1	80	1	90	1	98	1	106	1	124	1	143	2	145/175
H-1A	2	100	2	115	2	129	2	149	2	160	2	189	2	218	2	248
H-1B	2	25	2	30	4	34	4	38	4	43	4	52	4	58	6	67
H-1C	1	22	1	28	2	22/25	2	22/23	2	22/28	2	22/32	2	21/36	3	29/20/40
L-1	2	85 7/8	2	100	2	109	2	121	2	132 3/4	2	156	2	179	2	202
L-2	2	19	2	19	2	19	2	19	2	19	2	19	2	19	2	19
W-1A	4	61 3/4	4	68 3/4	4	74 3/4	4	81 1/2	3	87 1/2	3	100 1/2	4	114	4	127
W-1B	0	N/A	0	N/A	2	N/A	2	49	2	53	2	59	2	66	2	68
W-1C	0	N/A	0	N/A	2	34	2	34	2	35	2	40	2	43	2	47
W-2	4	25	4	28 1/2	4	32	4	35 1/4	4	38 1/4	6	44 3/4	6	51	6	57 1/2
TOT. WT.	51 lbs.		58 lbs.		72 lbs.		81 lbs.		86 lbs.		105 lbs.		126 lbs.		158 lbs.	

* c ALLOW 3/4"-1" EXTRA BAR LENGTH FOR HOLE FABRICATION

NOTES

- THIS HEADWALL SHALL BE USED ONLY WHEN PROTECTED BY GUARDRAIL OR INSTALLED OUTSIDE THE CLEAR ZONE.
- CAST-IN-PLACE HEADWALLS SHALL CONFORM TO SECTION 609 - MINOR STRUCTURES, OF THE CURRENT ITD STANDARD SPECIFICATIONS FOR HIGHWAY CONSTRUCTION.
- THE METAL REINFORCEMENT SHALL BE NO. 4 BARS. ALL REINFORCEMENT SHALL HAVE A MINIMUM CONCRETE COVER OF 2" AND 3" MINIMUM COVER IF CAST AGAINST EARTH.
- ALL EDGES TO HAVE 3/4" CHAMFER OR TOOLED EDGES.
- ALL PIPE CULVERTS WITH A CONCRETE HEADWALL SHALL HAVE THE INLET HEADWALLS BEVELED. USE ENTRANCE LOSS COEFFICIENT $K_e = 0.2$ FOR BEVELED ENTRANCES.
- THE METAL FOR THE GRATE SHALL MEET THE REQUIREMENTS OF ASTM A 36. WELDING OF THE METAL GRATE SHALL MEET THE REQUIREMENTS OF THE AMERICAN WELDING SOCIETY D1.1. GRATES FOR INLET HEADWALLS WILL BE REQUIRED ONLY WHEN SHOWN ON THE ROADWAY PLANS. GRATES NEED NOT BE PAINTED OR GALVANIZED.
- USE CONCRETE, METAL, OR PLASTIC PIPE WITH HEADWALL (CONCRETE PIPE SHOWN ON DRAWING).
- NOT TO SCALE.

ORIGINAL STORED AT: ITD, Headquarters 3311 West State Boise, Idaho

ORIGINAL SIGNED BY: MILDRED L. MILLER DATE ORIGINAL SIGNED: MARCH 4, 2005

REVISIONS							
NO.	DATE	BY	NO.	DATE	BY	NO.	DATE
1	02-68		6	12-92	TMR		
2	09-68		7	10-01	MSM		
3	10-69		8	06-03	MSM		
4	04-90	GB	9	03-05	MSM		
5	03-92	MSM					

SCALES SHOWN ARE FOR 11" X 17" PRINTS ONLY
CADD FILE NAME: d7_0305.dgn
DRAWING DATE: MAY, 1964

IDAHO TRANSPORTATION DEPARTMENT
BOISE IDAHO

ORIGINAL SIGNED BY: LOREN THOMAS
ASSISTANT CHIEF ENGINEER (DEVELOPMENT)
ORIGINAL SIGNED BY: STEVEN HUTCHINSON
CHIEF ENGINEER

STANDARD DRAWING
CONCRETE HEADWALL FOR TWIN PIPE CULVERTS
REQUIRES SHEET 1 OF 2

English
STANDARD DRAWING NO.
D-7
SHEET 2 OF 2