

**NOTES**

1. PATTERNS USED IN DRAWING:

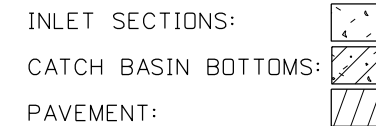

2. INLETS AND CATCH BASINS MAY BE EITHER PRECAST OR CAST-IN-PLACE. PRECAST UNITS SHALL MEET THE REQUIREMENTS OF ASTM C 913. (PRIOR APPROVAL OF SHOP DRAWINGS WILL BE REQUIRED ON MODIFIED UNITS.)
3. A 1" SIDE DRAFT IS ALLOWED FOR FORM REMOVAL.
4. CAST-IN-PLACE INLETS AND CATCH BASINS SHALL CONFORM TO SECTION 609 - MINOR STRUCTURES OF THE CURRENT ITD STANDARD SPECIFICATIONS FOR HIGHWAY CONSTRUCTION.
5. THE GRADE LINE OF THE TOP INSIDE OF ANY PIPE SHALL ENTER AT A POINT NO LOWER THAN THE TOP INSIDE OF THE OUTLET PIPE.
6. PIPES CAN ENTER OR LEAVE THE BOX IN ANY DIRECTION. ALL CONNECTIONS AND BROKEN AREAS SHALL BE GROUTED SMOOTH.
7. STEEL ANGLES SHALL BE SET SO THAT EACH BEARING BAR OF PREFABRICATED GRATE SHALL HAVE FULL BEARING ON BOTH ENDS. THE FINISHED TOP OF CONCRETE SHALL BE EVEN WITH THE ANGLE/GRATE SURFACE. THE STRUCTURAL STEEL NEED NOT BE PAINTED BUT SHALL MEET THE REQUIREMENTS OF ASTM A 36.
8. ALL METAL REINFORCEMENT USED SHALL BE NO. 4 BARS. THE METAL REINFORCEMENT SHALL BE SMOOTH CUT TO ACCOMMODATE PIPES.
9. GRAY IRON CAST TO THE DIMENSIONS GIVEN FOR THE STEEL GRATES MAY BE USED. THE CASTINGS SHALL CONFORM TO AASHTO M306 CLASS 35B GRAY IRON CASTINGS.
10. INLET/CATCH BASIN GRATES MAY EITHER BE RESISTANCE WELDED OR ARC WELDED. IN EITHER CASE THE GRATE SHALL BE TRUE AND FLUSH.
11. GRATE B WILL BE USED ONLY WHEN SPECIFIED.
12. NOT TO SCALE.

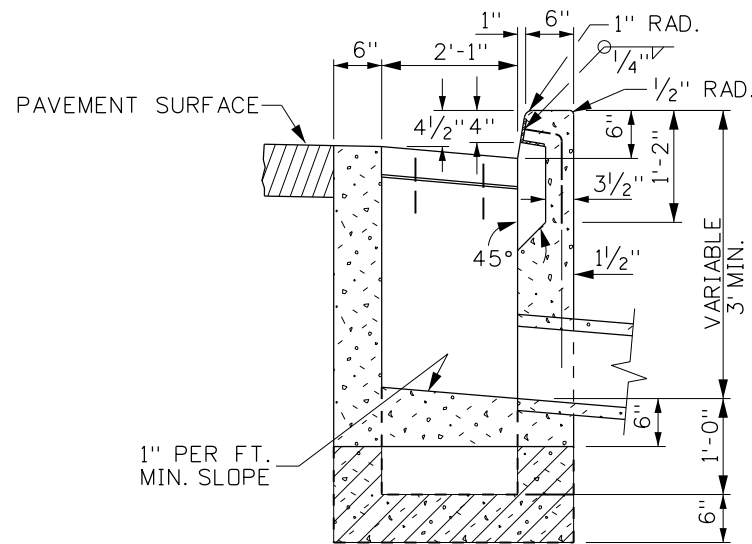
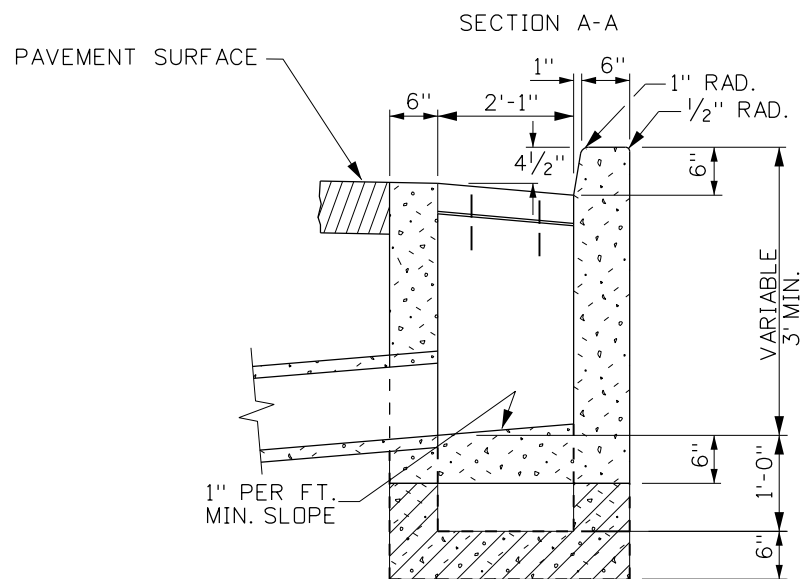

SECTION B-B  
INLET - TYPE 1A  
CATCH BASIN - TYPE 1A

SECTION B-B  
INLET - TYPE 2A  
CATCH BASIN - TYPE 2A

ORIGINAL STORED AT: ITD, Headquarters 3311 West State Boise, Idaho

ORIGINAL SIGNED BY:  
DATE: TED E. MASDN  
NOVEMBER 3, 2008

REVISIONS							
NO.	DATE	BY	NO.	DATE	BY	NO.	DATE
1	04-82		6	11-04	MSM		
2	01-89		7	11-08	JRV		
3	12-94	MSM					
4	06-97	MSM					
5	03-01	MSM					

SCALES SHOWN ARE FOR 11" X 17" PRINTS ONLY  
CADD FILE NAME: e6b\_1108.dgn  
DRAWING DATE: OCTOBER, 1980

**IDAHO TRANSPORTATION DEPARTMENT**



BOISE IDAHO

ORIGINAL SIGNED BY: LOREN THOMAS  
ASSISTANT CHIEF ENGINEER (DEVELOPMENT)  
ORIGINAL SIGNED BY: TOM COLE  
CHIEF ENGINEER

STANDARD DRAWING

**INLETS & CATCH BASINS  
TYPES 1A, 2A, & 3A**

REQUIRES SHEET 2 OF 2

**English**

STANDARD DRAWING NO.

**E-6-B**

SHEET 1 OF 2

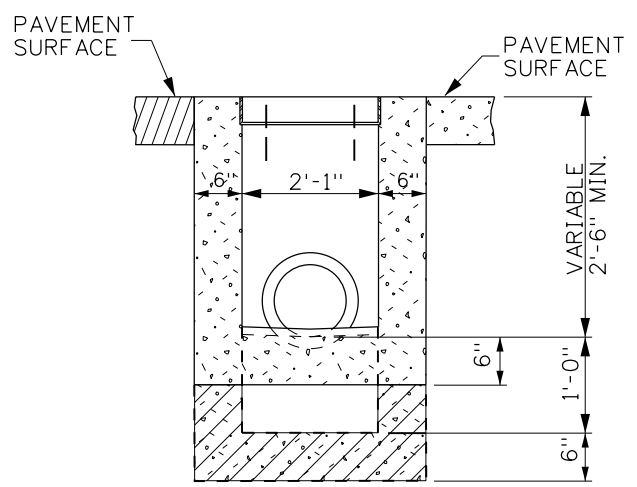
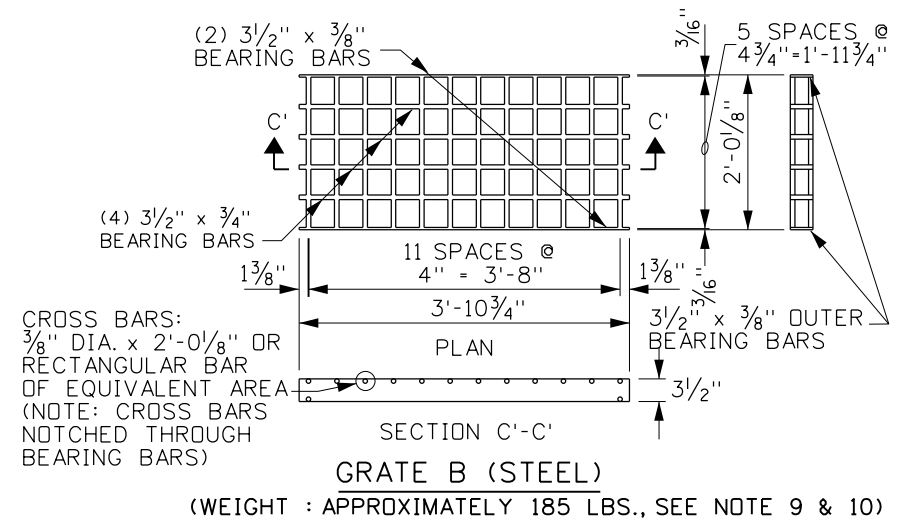
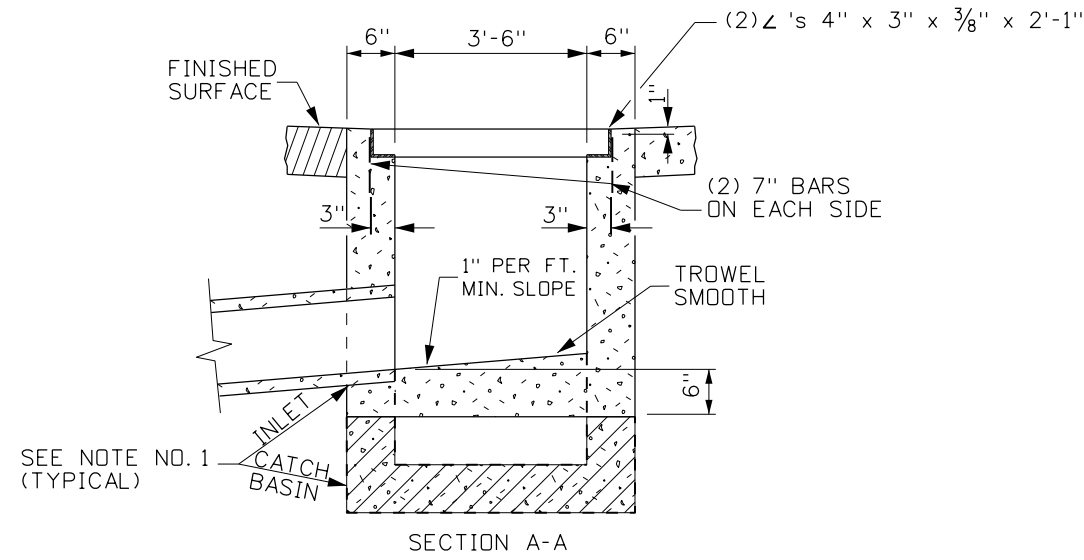
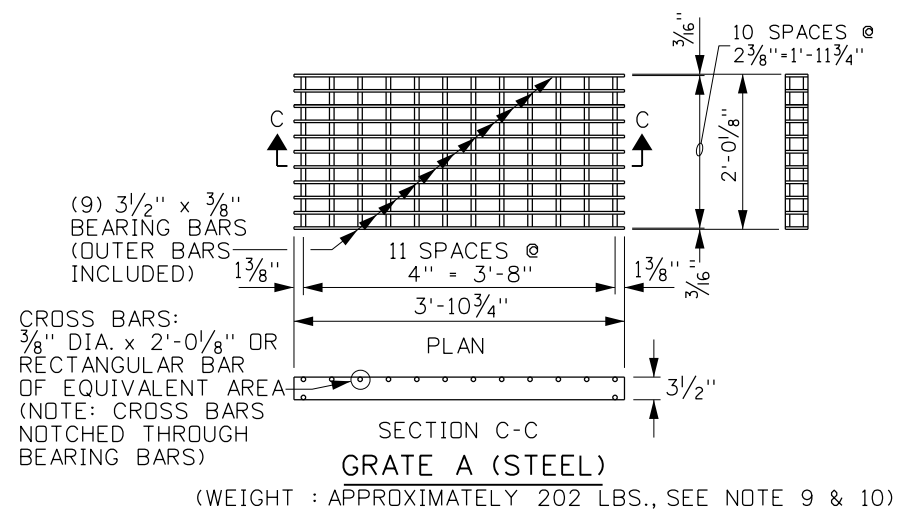
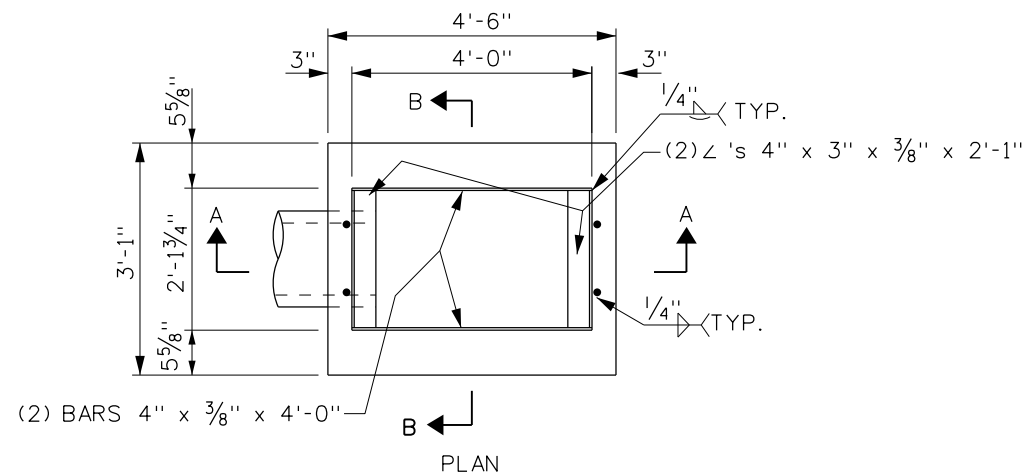

SECTION B-B  
INLET - TYPE 3A  
CATCH BASIN - TYPE 3A

ORIGINAL STORED AT: ITD, Headquarters 3311 West State Boise, Idaho

ORIGINAL SIGNED BY: DATE: TED E. MASDN NOVEMBER 3, 2008

REVISIONS								
NO.	DATE	BY	NO.	DATE	BY	NO.	DATE	BY
1	04-82		6	11-04	MSM			
2	01-89		7	11-08	JRV			
3	12-94	MSM						
4	06-97	MSM						
5	03-01	MSM						

SCALES SHOWN ARE FOR 11" X 17" PRINTS ONLY  
CADD FILE NAME: e6b\_1108.dgn  
DRAWING DATE: OCTOBER, 1980

IDAHO TRANSPORTATION DEPARTMENT  
BOISE IDAHO

ORIGINAL SIGNED BY: LOREN THOMAS  
ASSISTANT CHIEF ENGINEER (DEVELOPMENT)  
ORIGINAL SIGNED BY: TOM COLE  
CHIEF ENGINEER

STANDARD DRAWING  
INLETS & CATCH BASINS  
TYPES 1A, 2A, & 3A  
REQUIRES SHEET 1 OF 2

English  
STANDARD DRAWING NO.  
E-6-B  
SHEET 2 OF 2