

REINFORCING STEEL TABLE (SEE NOTE NOS. 2 & 3)				
MARK	LOCATION	BAR SIZE	NUMBER OF BARS	SKETCH
H-1	HORIZONTAL INSIDE BARRIER - TIED INSIDE AND UNDERNEATH V-1 BARS	NO. 5	10	9'-6"
V-1	VERTICAL IN BARRIER - 4 AT EACH END	NO. 5	8	4'-9" TOTAL BAR LENGTH 2'-5 5/8" (top) 10" OVER-LAP 1'-11" (height) 3" R (TYP.)

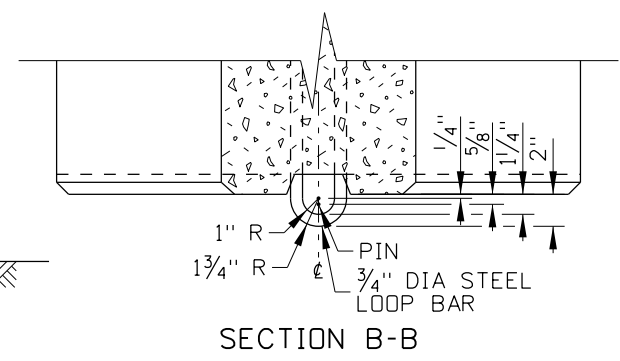

**NOTES**

1. PRECAST USING CONCRETE CLASS 40A. ENSURE THAT REINFORCING STEEL IS IN ACCORDANCE WITH SECTION 708 - METALS OF THE STANDARD SPECIFICATIONS FOR HIGHWAY CONSTRUCTION. PROVIDE 2" MINIMUM CONCRETE COVER OVER REINFORCING STEEL UNLESS OTHERWISE NOTED.
2. ENSURE THAT REINFORCING STEEL BENDS ARE MADE IN ACCORDANCE WITH THE LATEST A.C.I. STANDARD PRACTICES AND AASHTO SPECIFICATIONS.
3. THE DIMENSIONS SHOWN IN THE STEEL REINFORCING TABLE ARE MEASURED FROM OUTSIDE-TO-OUTSIDE (O. TO O.) OF BENDS OR BAR ENDS UNLESS OTHERWISE NOTED.
4. PIN CONNECT BARRIER UNITS WHEN POSTED HIGHWAY SPEEDS ARE 35 MPH OR HIGHER.
5. TRANSITION THE TALL CONCRETE MEDIAN BARRIER TO THE 32" HEIGHT 20' OR 10' CONCRETE BARRIER OR TERMINATE THE BARRIER WITH A CRASHWORTHY TERMINAL. ACCEPTABLE TERMINALS MAY INCLUDE CONNECTION TO W-BEAM OR THRIE-BEAM GUARDRAIL, OR CONNECTION TO A CRASH CUSHION. TRANSITION TO THE 32" HEIGHT 20' OR 10' CONCRETE BARRIER USING THE TALL TO STANDARD TRANSITION BARRIER SHOWN ON STANDARD DRAWING G-2-I-2.
6. WHEN PLACED IN NARROW PAVED MEDIANS, PLACE REFLECTORS ON BOTH SIDES OF THE BARRIER.
7. NOT TO SCALE.

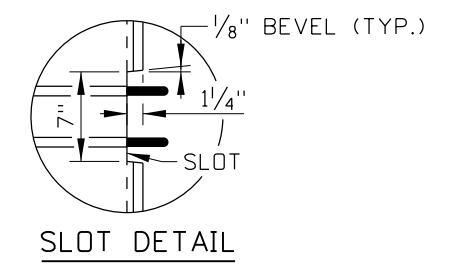
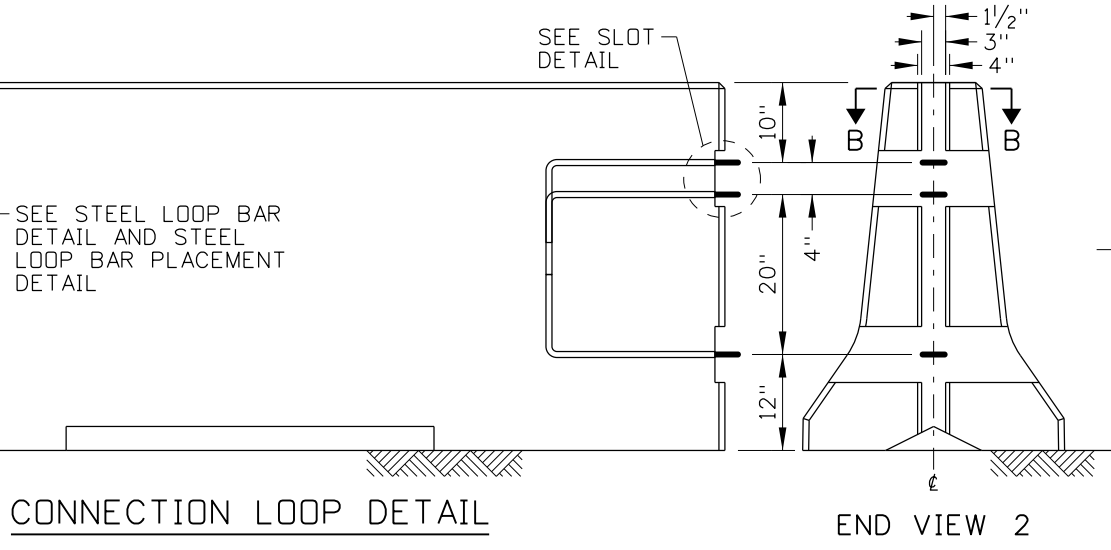
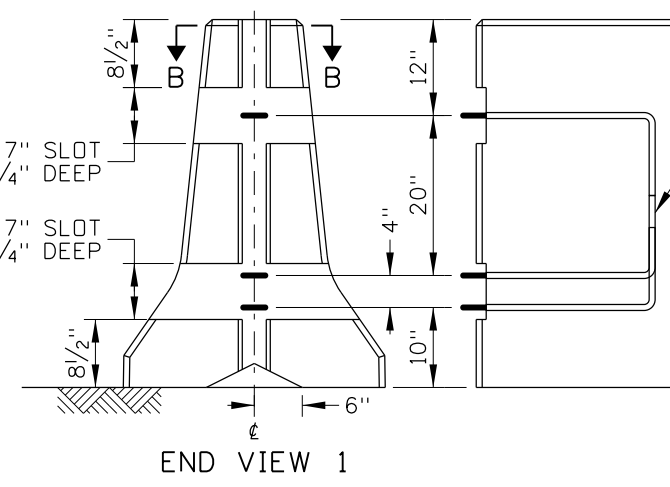
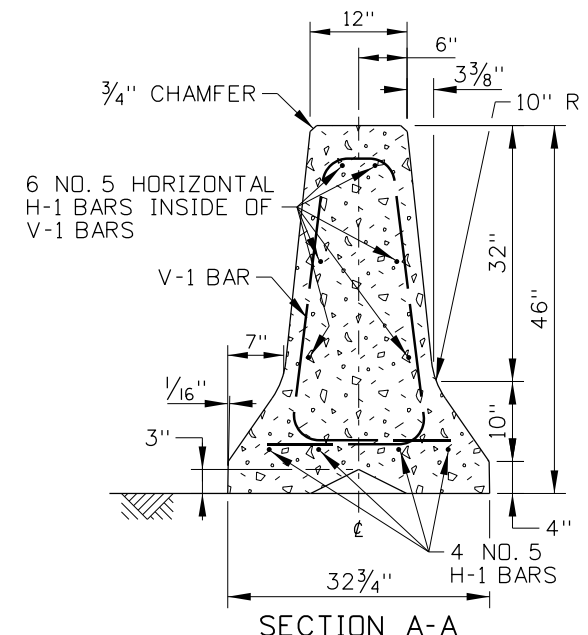
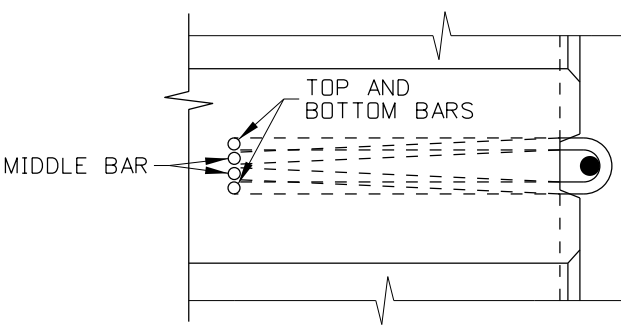
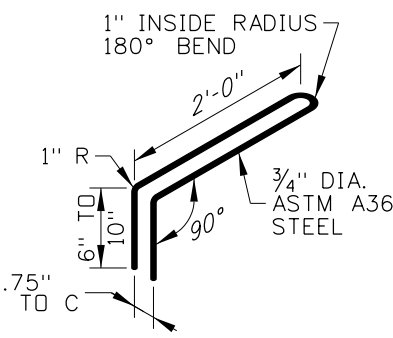
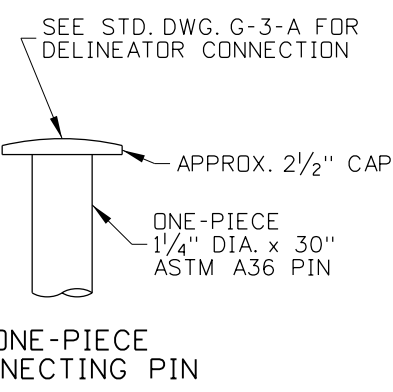
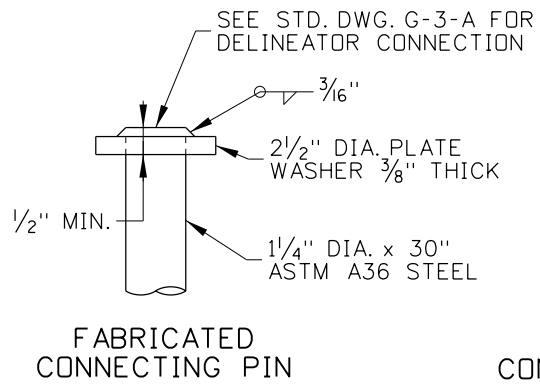

**CONNECTING PIN DETAIL**  
(SEE NOTE NO. 4)

**STEEL LOOP BAR DETAIL**

**STEEL LOOP BAR PLACEMENT DETAIL**

REVISIONS							
NO.	DATE	BY	NO.	DATE	BY	NO.	DATE
1	04-13	RDL					

SCALES SHOWN ARE FOR 11" X 17" PRINTS ONLY  
CADD FILE NAME: g2i1\_0613.std  
DRAWING DATE: OCTOBER, 2004

**IDAHO TRANSPORTATION DEPARTMENT**

BOISE IDAHO

ORIGINAL SIGNED BY: LOREN THOMAS  
HIGHWAYS PROGRAM OVERSIGHT ENGINEER

ORIGINAL SIGNED BY: TOM COLE  
CHIEF ENGINEER

STANDARD DRAWING  
**TALL CONCRETE MEDIAN BARRIER**

**English**  
STANDARD DRAWING NO.  
**G-2-I-1**  
SHEET 1 OF 1

ORIGINAL STORED AT: ITD, Headquarters 3311 West State Boise, Idaho

ORIGINAL SIGNED BY: RYAN D. LANCASTER  
DATE ORIGINAL SIGNED: MAY 9, 2013