

REINFORCING STEEL TABLE (SEE NOTE NOS. 2 & 3)				
MARK	LOCATION	BAR SIZE	NUMBER OF BARS	SKETCH
H-1	HORIZONTAL INSIDE BARRIER - TIED INSIDE AND UNDER-NEATH V-1 BARS	NO. 5	8	9'-6"
V-1, V-2, V-3, V-4, V-5, V-6, V-7, V-8	VERTICAL IN BARRIER - 4 AT EACH END (SEE VERTICAL METAL REINFORCEMENT DIMENSIONS TABLE)	NO. 5	8	

VERTICAL REINFORCING STEEL DIMENSIONS								
MARK	V-1	V-2	V-3	V-4	V-5	V-6	V-7	V-8
TOTAL LENGTH	7'-1"	6'-11 1/2"	6'-8"	6'-4 1/2"	5'-4 1/2"	5'-0 1/2"	4'-10 1/2"	4'-9 1/2"
A	3'-2"	3'-1 1/2"	3'	2'-10 1/2"	2'-5 1/2"	2'-4"	2'-2 1/2"	2'-2"
B	3 1/2"	3"	2 1/2"	2"	0"	0"	0"	0"

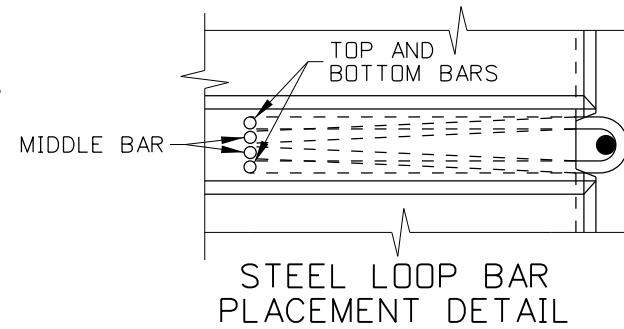
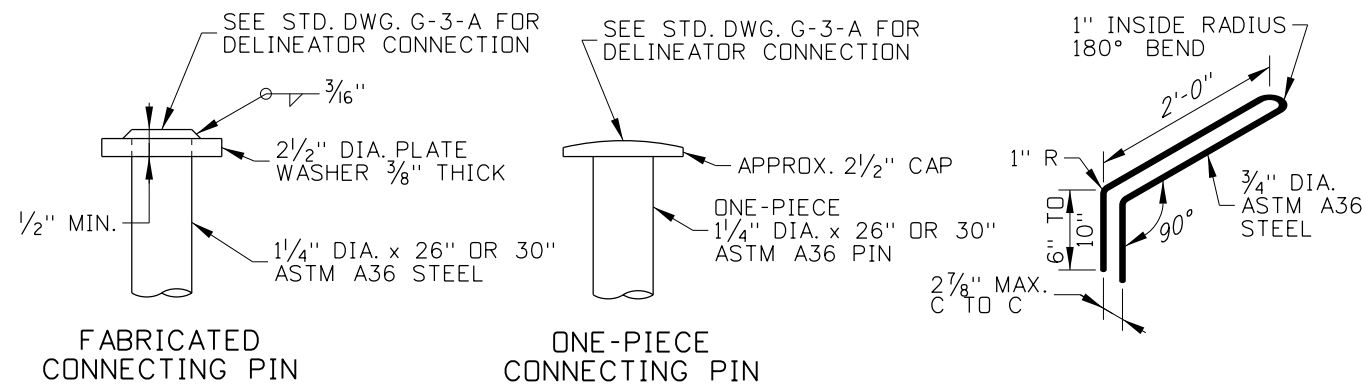
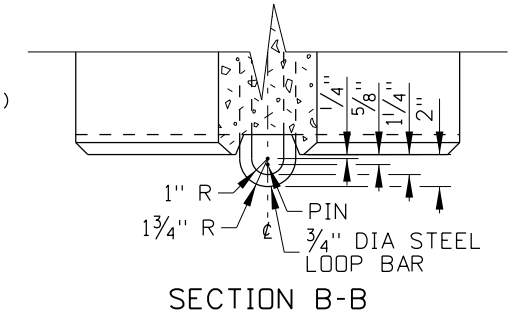
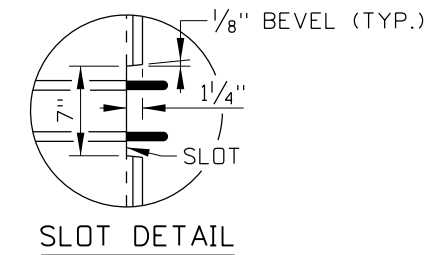
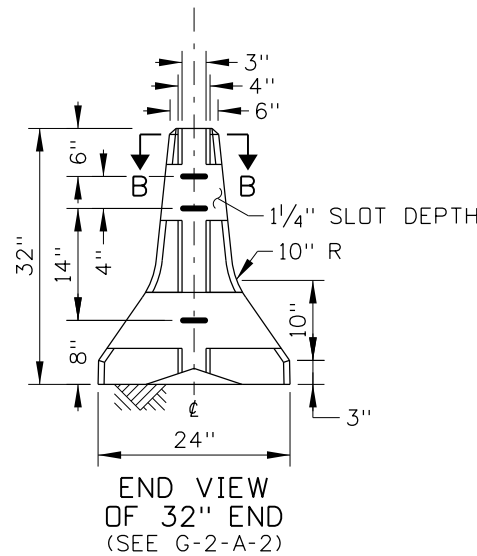
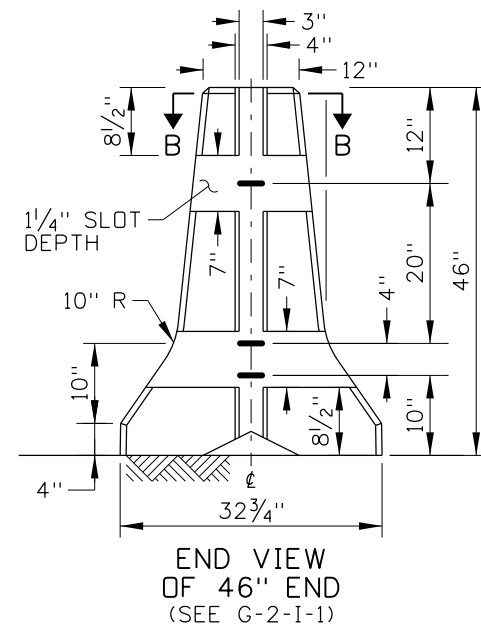
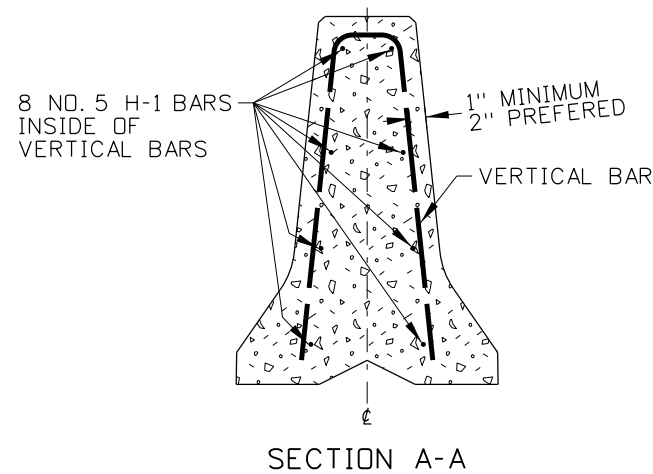

**NOTES**

1. PRECAST USING CONCRETE CLASS 40A. ENSURE THAT REINFORCING STEEL IS IN ACCORDANCE WITH SECTION 708 - METALS OF THE STANDARD SPECIFICATIONS FOR HIGHWAY CONSTRUCTION. PROVIDE 2" MINIMUM CONCRETE COVER OVER REINFORCING STEEL UNLESS OTHERWISE NOTED.
2. ENSURE THAT REINFORCING STEEL BENDS ARE MADE IN ACCORDANCE WITH THE LATEST A.C.I. STANDARD PRACTICES AND AASHTO SPECIFICATIONS.
3. THE DIMENSIONS SHOWN IN THE REINFORCING STEEL TABLE ARE MEASURED FROM OUTSIDE-TO-OUTSIDE (O. TO O.) OF BENDS OR BAR ENDS UNLESS OTHERWISE NOTED.
4. PIN CONNECT BARRIER UNITS WHEN POSTED HIGHWAY SPEEDS ARE 35 MPH OR HIGHER.
5. WHEN PLACED IN NARROW PAVED MEDIANS, PLACE REFLECTORS ON BOTH SIDES OF THE BARRIER.
6. NOT TO SCALE.

ORIGINAL STORED AT: ITD, Headquarters 3311 West State Boise, Idaho

ORIGINAL SIGNED BY: RYAN D. LANCASTER DATE ORIGINAL SIGNED: MAY 9, 2013

REVISIONS							
NO.	DATE	BY	NO.	DATE	BY	NO.	DATE
1	04-13	RDL					

SCALES SHOWN ARE FOR 11" X 17" PRINTS ONLY  
 CADD FILE NAME: g2i2\_0613.std  
 DRAWING DATE: OCTOBER, 2004

**IDAHO TRANSPORTATION DEPARTMENT**

BOISE IDAHO

ORIGINAL SIGNED BY: LOREN THOMAS  
 HIGHWAYS PROGRAM OVERSIGHT ENGINEER

ORIGINAL SIGNED BY: TOM COLE  
 CHIEF ENGINEER

STANDARD DRAWING  
**TALL TO STANDARD CONCRETE BARRIER TRANSITION**  
 REQUIRES STD. DWG. G-2-A-2 & G-2-I-1

**English**  
 STANDARD DRAWING NO.  
**G-2-I-2**  
 SHEET 1 OF 1