

FRONT VIEW

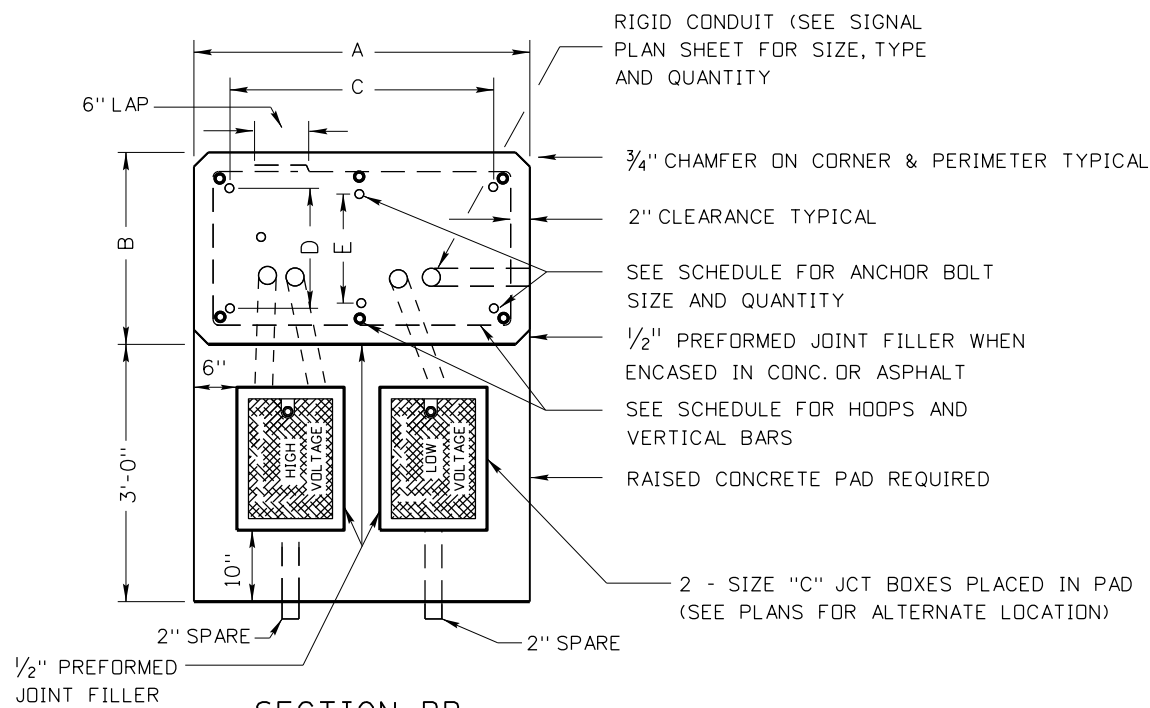

SECTION BB

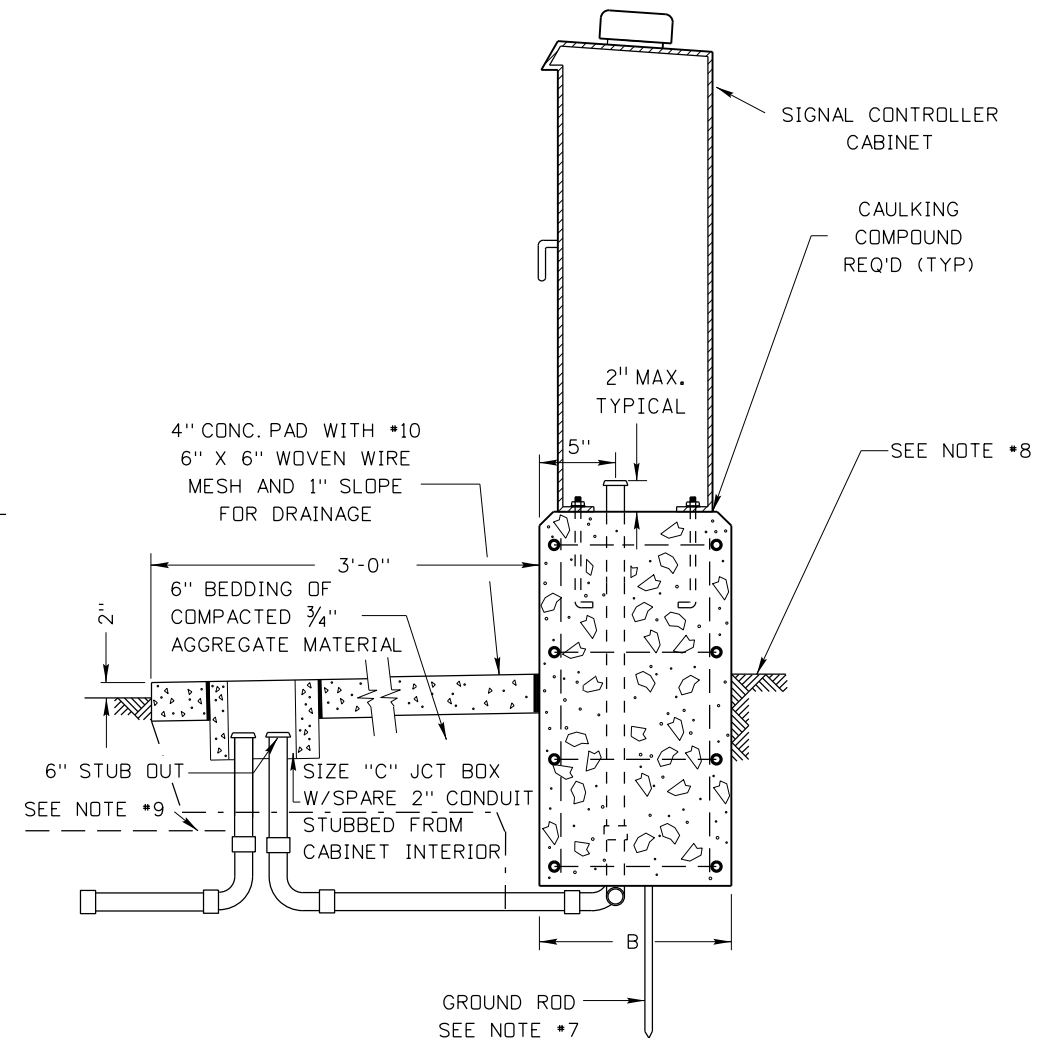

SECTION AA

NOTES:

1. THE FOUNDATION SHALL BE LOCATED AS INDICATED ON THE PROJECT PLAN SHEETS.
2. FOUNDATION REBAR CAGES MAY BE WELDED IF THE REBAR CONFORMS TO ASTM A706/A706M AND ALL WELDING CONFORMS TO ANSI/AWS D1.4 (STRUCTURAL WELDING CODE - REINFORCING STEEL).
3. ALL CONDUITS, ELBOWS, AND COUPLINGS WITHIN AND PROTRUDING FROM THE FOUNDATION SHALL BE RIGID STEEL. THE REMAINING CONDUITS SHALL BE AS SHOWN ON THE PLANS.
4. STUBOUTS SHALL BE TERMINATED WITH A STEEL BONDING BUSHING.
5. FOAM PLUG REQUIRED AT BOTH ENDS OF SPARE CONDUITS.
6. GROUND IN ACCORDANCE WITH N.E.C.
7. CONDUIT SHALL BE INSTALLED IN SUCH A MANNER AS TO NOT CAUSE MODIFICATION OF THE CABINETS.
8. GRADE AREA TO PROVIDE DRAINAGE AWAY FROM CABINET FOUNDATION.
9. 6" WIDE ELECTRICAL HAZARD TAPE INSTALLED 1'-0" ABOVE CONDUIT (TYPICAL OF ALL CONDUIT PLACED IN GROUND).
10. NOT TO SCALE.

CABINET FOUNDATION SCHEDULE

CABINET TYPE	FOUNDATION TYPE	A	B	C	D	E	HOOPS			VERTICAL RODS			CU. YDS. CONC.		CABINET ANCHOR BOLT	
							NO.	SIZE	LIN. FT.	NO.	SIZE	LIN. FT.	FOUNDATION	PAD	QNTY.	SIZE
SIGNAL	M	2'-9"	1'-8"	-	-	1'-0"	4	#4	32'-0"	6	#4	19'-0"	.6	.14	2	3/4" X 18" X 2 1/4"
	P & R	3'-11"	2'-5"	3'-4 3/4"	1'-6 1/2"	-	4	#4	47'-4"	6	#4	19'-0"	1.23	.14	4	3/4" X 18" X 2 1/4"

ORIGINAL STORED AT: ITD, Headquarters 3311 West State Boise, Idaho

ORIGINAL SIGNED BY: ROBERT KOEBERLEIN DATE ORIGINAL SIGNED: JUNE 19, 2014

REVISIONS							
NO.	DATE	BY	NO.	DATE	BY	NO.	DATE

SCALES SHOWN ARE FOR 11" X 17" PRINTS ONLY
 CADD FILE NAME: i7a20514.dgn
 DRAWING DATE: MAY, 2014

IDAHO TRANSPORTATION DEPARTMENT

BOISE IDAHO

ORIGINAL SIGNED BY: CARL D. MAIN
 DESIGN/TRAFFIC SERVICES ENGINEER

STANDARD DRAWING
SIGNAL CABINET FOUNDATION DETAIL

English
 STANDARD DRAWING NO.
I-7-A-2
 SHEET 1 OF 1