

URBAN LOCATIONS  
WITH CURB AND GUTTER

SIGN HEIGHT AND LATERAL LOCATION

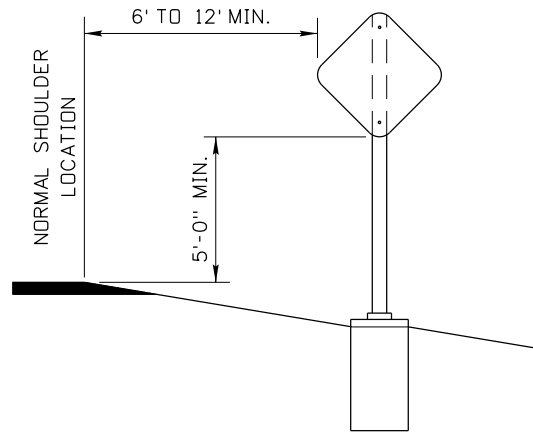

RURAL LOCATIONS  
(SEE NOTE 3 WHEN SOLID ROCK IS ENCOUNTERED)

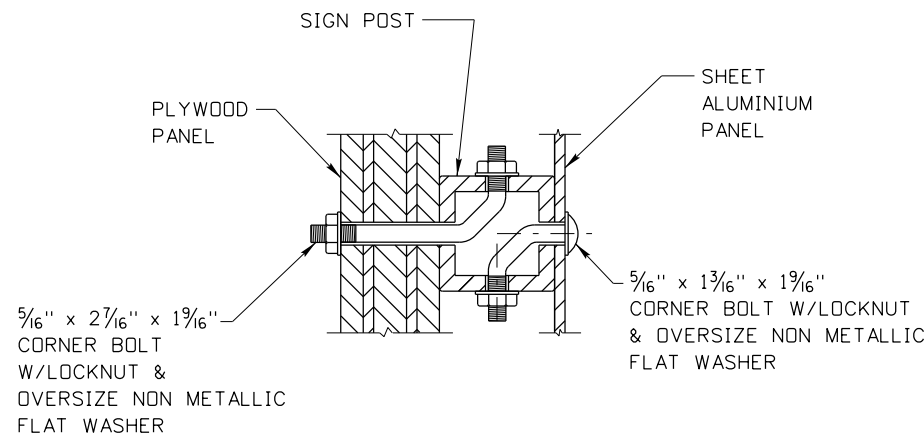

5/16" x 2 7/16" x 1 9/16"  
CORNER BOLT  
W/LOCKNUT &  
OVERSIZE NON METALLIC  
FLAT WASHER

SHEET  
ALUMINIUM  
PANEL

5/16" x 1 3/16" x 1 9/16"  
CORNER BOLT W/LOCKNUT  
& OVERSIZE NON METALLIC  
FLAT WASHER

CORNER BOLTS MAY BE USED WITH BACK TO BACK INSTALLATIONS

BACK TO BACK SIGN MOUNTING DETAILS

**NOTES**

1. ENSURE THAT THE BOTTOM OF ANCHOR IS KEPT OPEN TO DRAIN.
2. DO NOT USE MORE THAN ONE POST PER SIGN INSTALLATION.
3. INSTALL SIGN POST AND ANCHOR IN FOUNDATION OR GROUT INTO SOLID ROCK. IF INSTALLED IN ROCK, ENSURE THAT THE 2" X 2" POST INSTALLATIONS ARE EMBEDDED 18" ONTO SOLID ROCK AND 2 1/2" X 2 1/2" POST INSTALLATIONS ARE EMBEDDED 24" INTO SOLID ROCK.
4. DO NOT USE BRACE ANGLES.
5. DRAWING NOT TO SCALE.

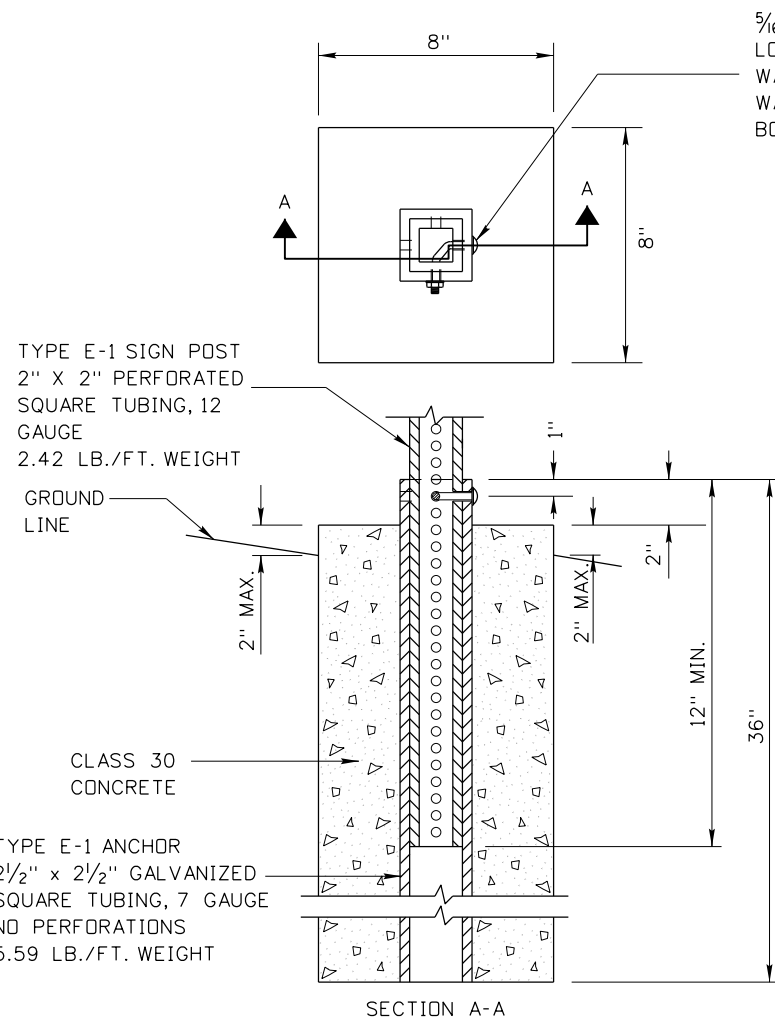

TYPE E-1 SIGN POST  
2" X 2" PERFORATED  
SQUARE TUBING, 12  
GAUGE  
2.42 LB./FT. WEIGHT

GROUND  
LINE

CLASS 30  
CONCRETE

TYPE E-1 ANCHOR  
2 1/2" X 2 1/2" GALVANIZED  
SQUARE TUBING, 7 GAUGE  
NO PERFORATIONS  
5.59 LB./FT. WEIGHT

SECTION A-A

2" X 2" SIGN POST INSTALLATION DETAILS  
TYPE E-1

5/16" CORNER BOLT WITH  
LOCKNUT & TWO FLAT  
WASHERS OR A 5/16" FLANGE  
WASHER NUT. SEE CORNER  
BOLT DETAIL.

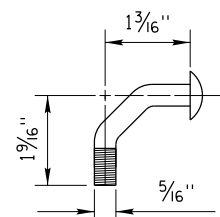

CORNER BOLT  
DETAIL

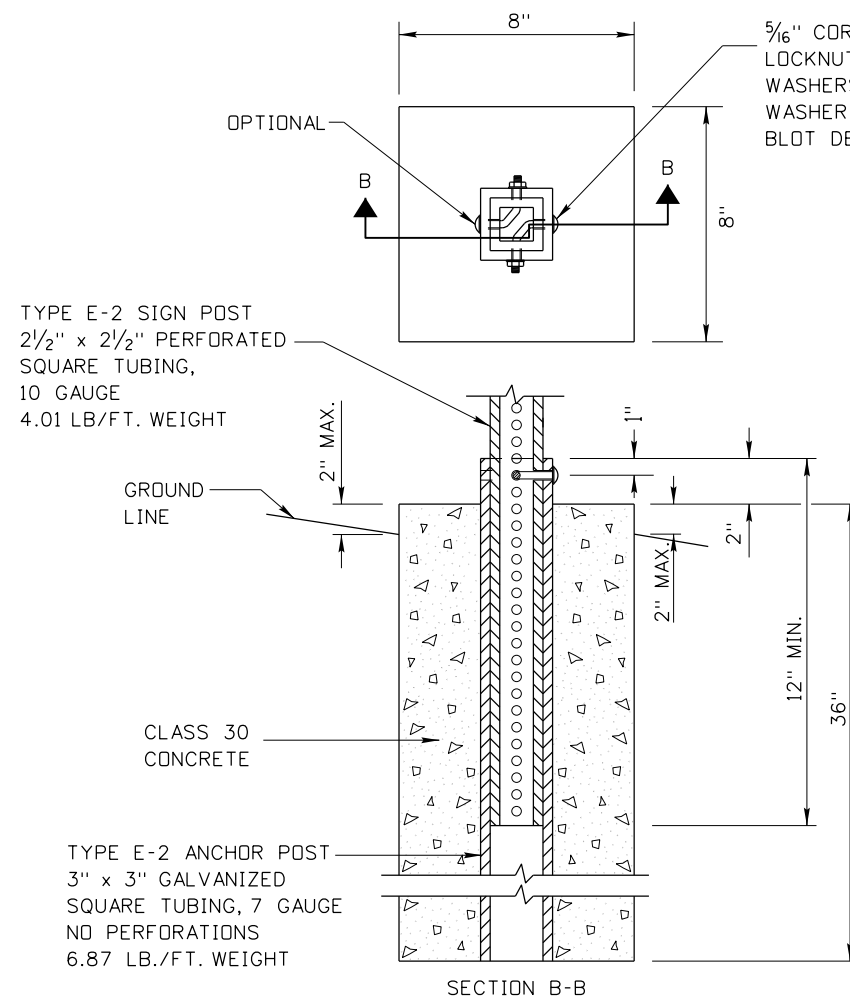

TYPE E-2 SIGN POST  
2 1/2" X 2 1/2" PERFORATED  
SQUARE TUBING,  
10 GAUGE  
4.01 LB./FT. WEIGHT

GROUND  
LINE

CLASS 30  
CONCRETE

TYPE E-2 ANCHOR POST  
3" X 3" GALVANIZED  
SQUARE TUBING, 7 GAUGE  
NO PERFORATIONS  
6.87 LB./FT. WEIGHT

SECTION B-B

2 1/2" X 2 1/2" SIGN POST INSTALLATION DETAILS  
TYPE E-2

5/16" CORNER BOLT WITH  
LOCKNUT & TWO FLAT  
WASHERS OR A 5/16" FLANGE  
WASHER NUT. SEE CORNER  
BOLT DETAIL.

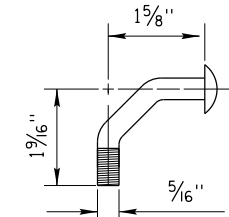

CORNER BOLT  
DETAIL

REVISIONS							
NO.	DATE	BY	NO.	DATE	BY	NO.	DATE
1	02-92	JEC	6	05-15	HEB		
2	12-94	HEB	7	12-15	HEB		
3	06-99	HEB					
4	12-01	NQB					
5	12-13	HEB					

SCALES SHOWN  
ARE FOR 11" X 17"  
PRINTS ONLY

CADD FILE NAME:  
i8f\_1215.dgn

DRAWING DATE:  
JULY, 1991

**IDAHO  
TRANSPORTATION  
DEPARTMENT**



BOISE IDAHO

ORIGINAL SIGNED BY: KEVIN SABLAN  
DESIGN/TRAFFIC SERVICES ENGINEER

STANDARD DRAWING  
**BREAKAWAY STEEL  
SIGN POSTS  
TYPE E**

English  
STANDARD DRAWING NO.  
**I-8-F**  
SHEET 1 OF 1

ORIGINAL STORED  
AT: ITD,  
Headquarters  
3311 West State  
Boise, Idaho

ORIGINAL SIGNED BY:  
RYAN D. LANCASTER  
DATE ORIGINAL SIGNED:  
DECEMBER 17, 2015