

MINIMUM DIMENSIONS SHOWN. SITE CONDITIONS WILL DETERMINE ACTUAL DIMENSIONS.

GABION OUTLET WEIR

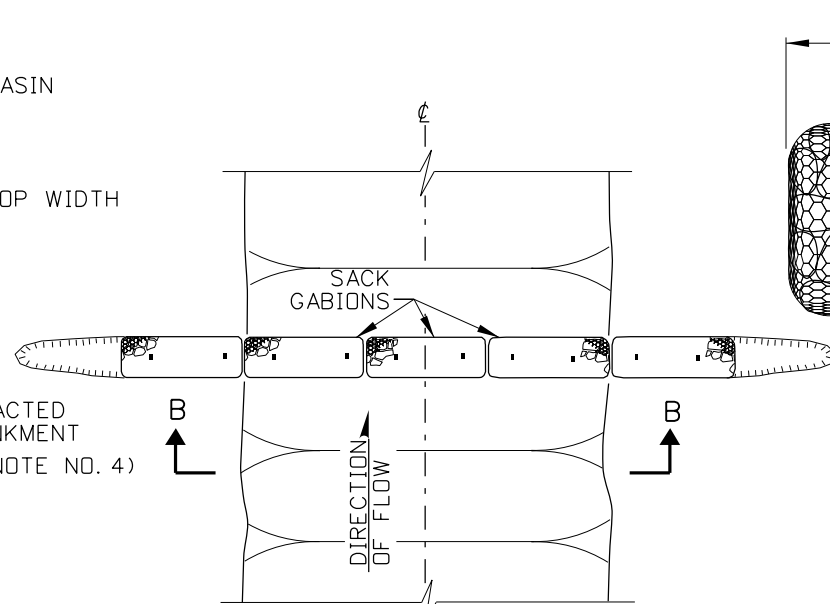

GABION CHECK DAM

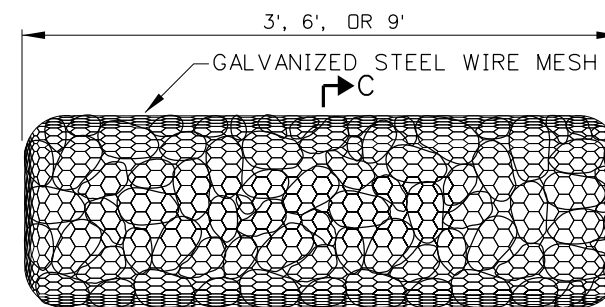

SACK GABION

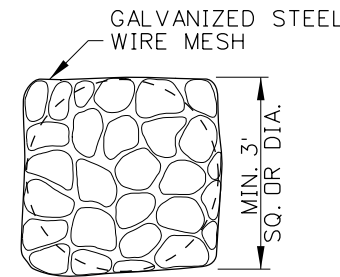

SECTION C-C

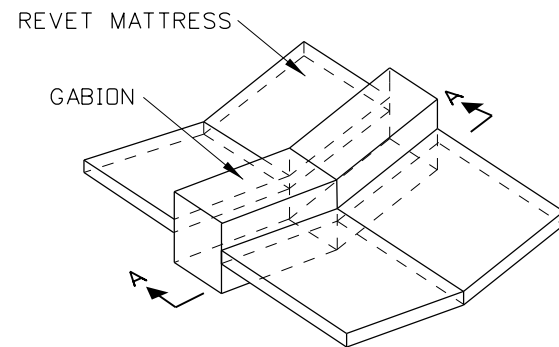

REVE MATTRESSES WITH GABIONS

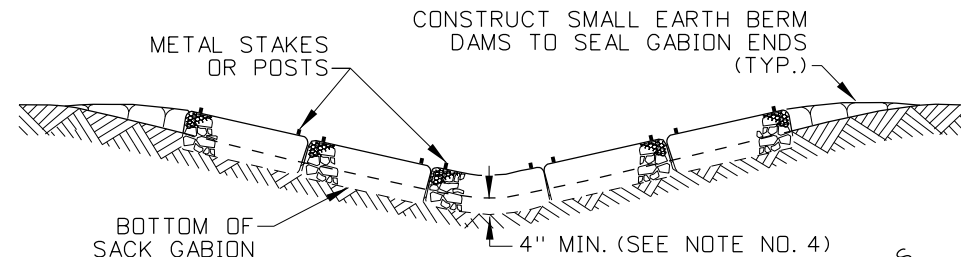

SECTION B-B

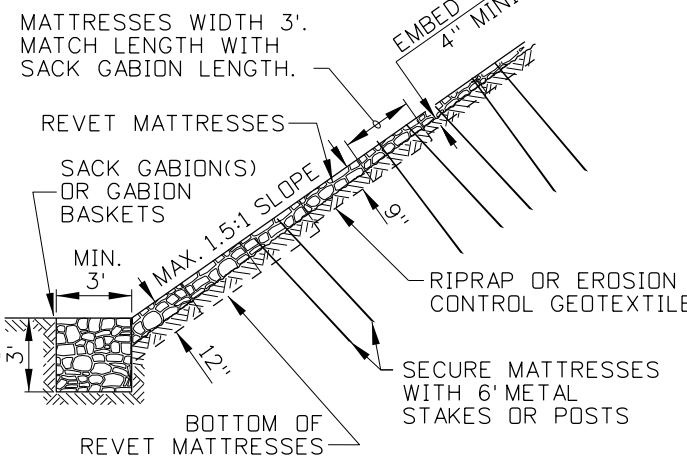

TYPICAL SLOPE SECTION SLOPE REVETMENT

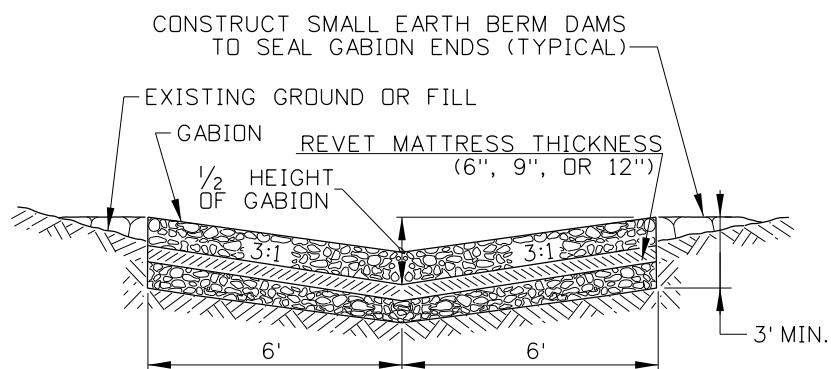

SECTION A-A

GENERAL NOTES FOR PERMANENT EROSION CONTROL

1. USE PERMANENT EROSION CONTROL DEVICES STANDARD DRAWINGS IN CONJUNCTION WITH THE STANDARD SPECIFICATIONS FOR HIGHWAY CONSTRUCTION AND THE ITD BEST MANAGEMENT PRACTICES MANUAL.
2. SEE PLANS FOR SITE DIMENSIONS.
3. THE PLACEMENT OF PERMANENT EROSION CONTROL MEASURES IS SITE SPECIFIC. OBTAIN THE ENGINEER'S APPROVAL OF THE PERMANENT EROSION CONTROL MEASURES PRIOR TO INSTALLATION.
4. PERMANENT EROSION CONTROL DEVICES ARE INTENDED TO LAST MORE THAN 6 MONTHS AND SHOULD BE INTEGRATED THE FINAL EROSION CONTROL PLAN.

NOTES

1. OBTAIN APPROPRIATE PERMITS BEFORE EROSION DEVICES ARE PLACED IN STREAMS AND, CHANNELS, OR BOTH.
2. GABIONS AND REVET MATTRESSES MAY BE USED FOR PERMANENT EROSION CONTROL, TEMPORARY EROSION CONTROL, OR BOTH.
3. THE DISCHARGE THROUGH OR OVER REVET MATTRESSES, GABIONS, OR BOTH SHOULD BE DIRECTED ONTO STABILIZED AREA SUCH AS VEGETATION, RIPRAP, OR BOTH.
4. GABIONS AND REVET MATTRESSES SHOULD BE EMBEDDED A MINIMUM OF 4" INTO THE EXISTING GROUND.
5. ALL SACK GABIONS SHOULD BE SECURED WITH 6" x 3/4" METAL STAKES OR 6" STEEL POSTS.
6. ENSURE THAT THE WIDTH OF THE GABION OUTLET WEIR IS CONSTRUCTED AS SHOWN ON THE PLANS OR AS DIRECTED BY THE ENGINEER.
7. GABIONS MAY BE USED WITH REVET MATTRESSES TO FORM SEDIMENT CONTROL DAMS AND SHOULD BE INSTALLED SO THAT THE CHANNEL CAPACITY IS NOT RESTRICTED SHOULD THE DEVICE TOTALLY SILT-UP. REVET MATTRESSES MAY BE USED AS A CHANNEL LINER TO PREVENT EROSION AND TO INTERCEPT SEDIMENT LADEN RUNOFF.
8. 6" REVET MATTRESSES WILL USUALLY PROMOTE VEGETATION FOR SIDE SLOPES THAT ARE NOT CONTINUALLY SUBMERGED IN WATER. 9" REVET MATTRESSES MAY BE USED TO LINE LARGE CHANNELS OR STREAMS WITH GREATER FLOW RATES OR IN SOILS THAT ERODE EASILY. 12" REVET MATTRESSES MAY BE USED TO LINE LARGE STREAMS AND RIVERS.
9. SECURE REVET MATTRESSES USED FOR SLOPE REVETMENT WITH METAL POSTS OR STAKES TO PREVENT SLIDING OR SHIFTING.
10. NOT TO SCALE.

REVISIONS							
NO.	DATE	BY	NO.	DATE	BY	NO.	DATE
1	02-96	MSM					
2	10-10	KEH					
3	10-11	KEH					
4	01-13	RDL					

SCALES SHOWN ARE FOR 11" X 17" PRINTS ONLY
 CADD FILE NAME: p2a_0213.std
 DRAWING DATE: JANUARY, 1994

IDAHO TRANSPORTATION DEPARTMENT



BOISE IDAHO

ORIGINAL SIGNED BY: LOREN THOMAS
 HIGHWAYS PROGRAM OVERSIGHT ENGINEER

ORIGINAL SIGNED BY: TOM COLE
 CHIEF ENGINEER

STANDARD DRAWING

EROSION AND SEDIMENT CONTROL GABIONS AND REVET MATTRESSES

English

STANDARD DRAWING NO. **P-2-A**

SHEET 1 OF 1

ORIGINAL STORED AT: ITD, Headquarters 3311 West State Boise, Idaho

ORIGINAL SIGNED BY: J. CALEB LAKEY
 DATE ORIGINAL SIGNED: FEBRUARY 1, 2013