

**RAIL WATERPROOFING DETAIL**  
NTS

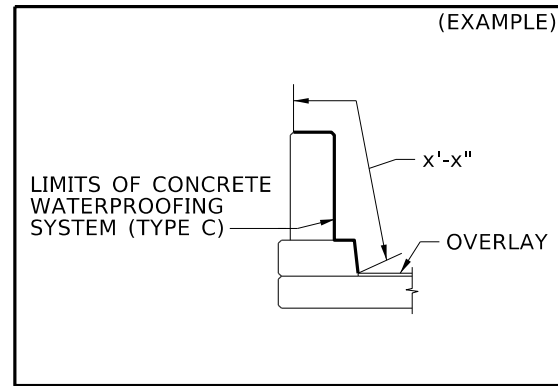

**(CURB/ENDBLOCK) WATERPROOFING DETAIL**  
NTS

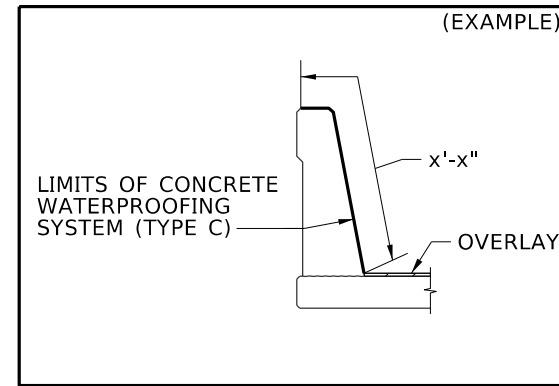

**PARAPET WATERPROOFING DETAIL**  
NTS

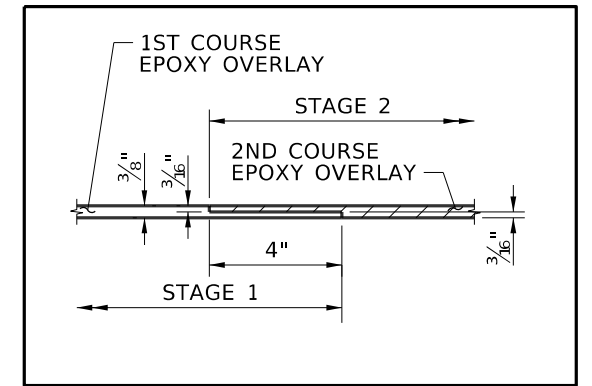

**EPOXY OVERLAY JOINT DETAIL**  
NTS

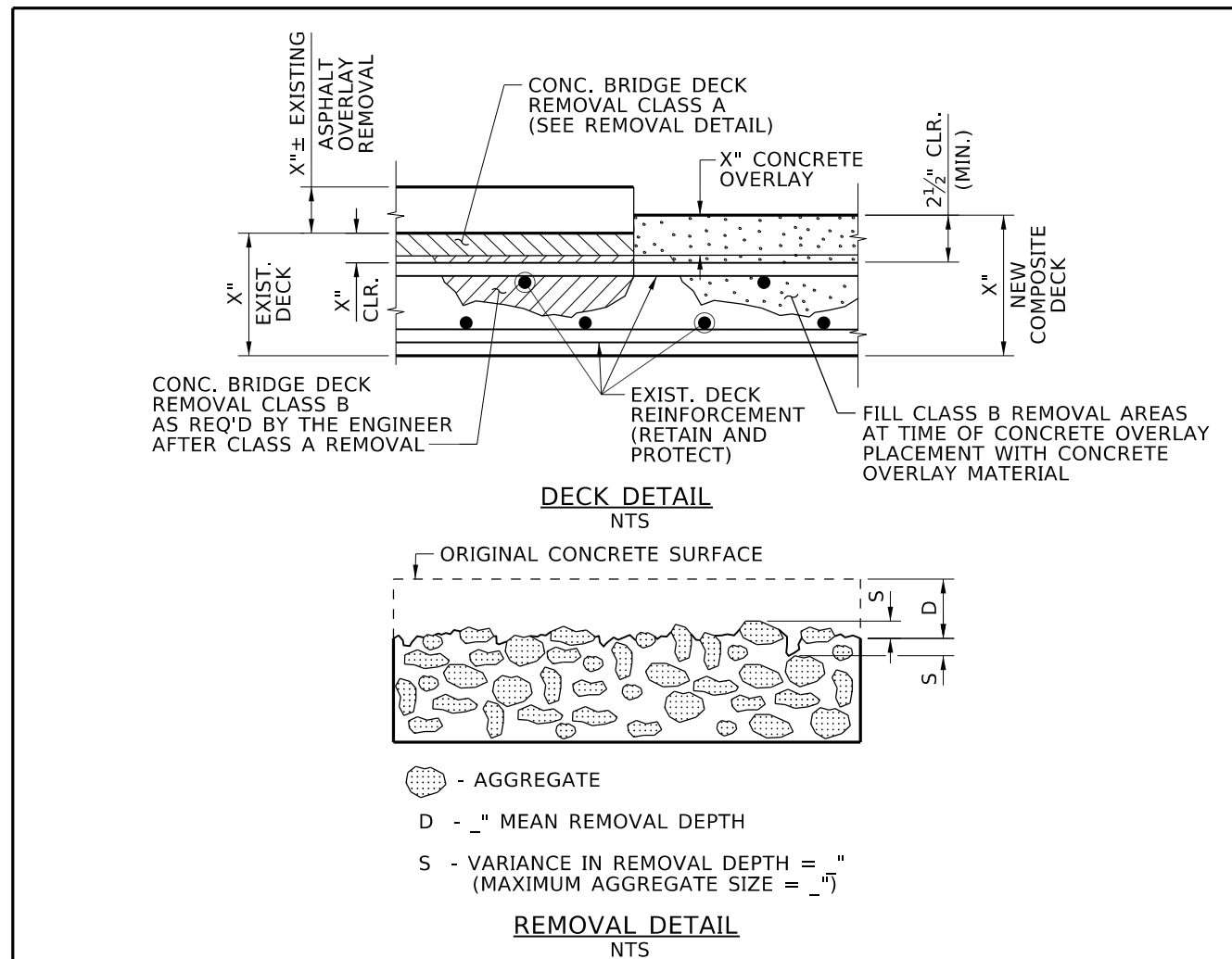

**CONCRETE OVERLAY DETAILS**  
NTS

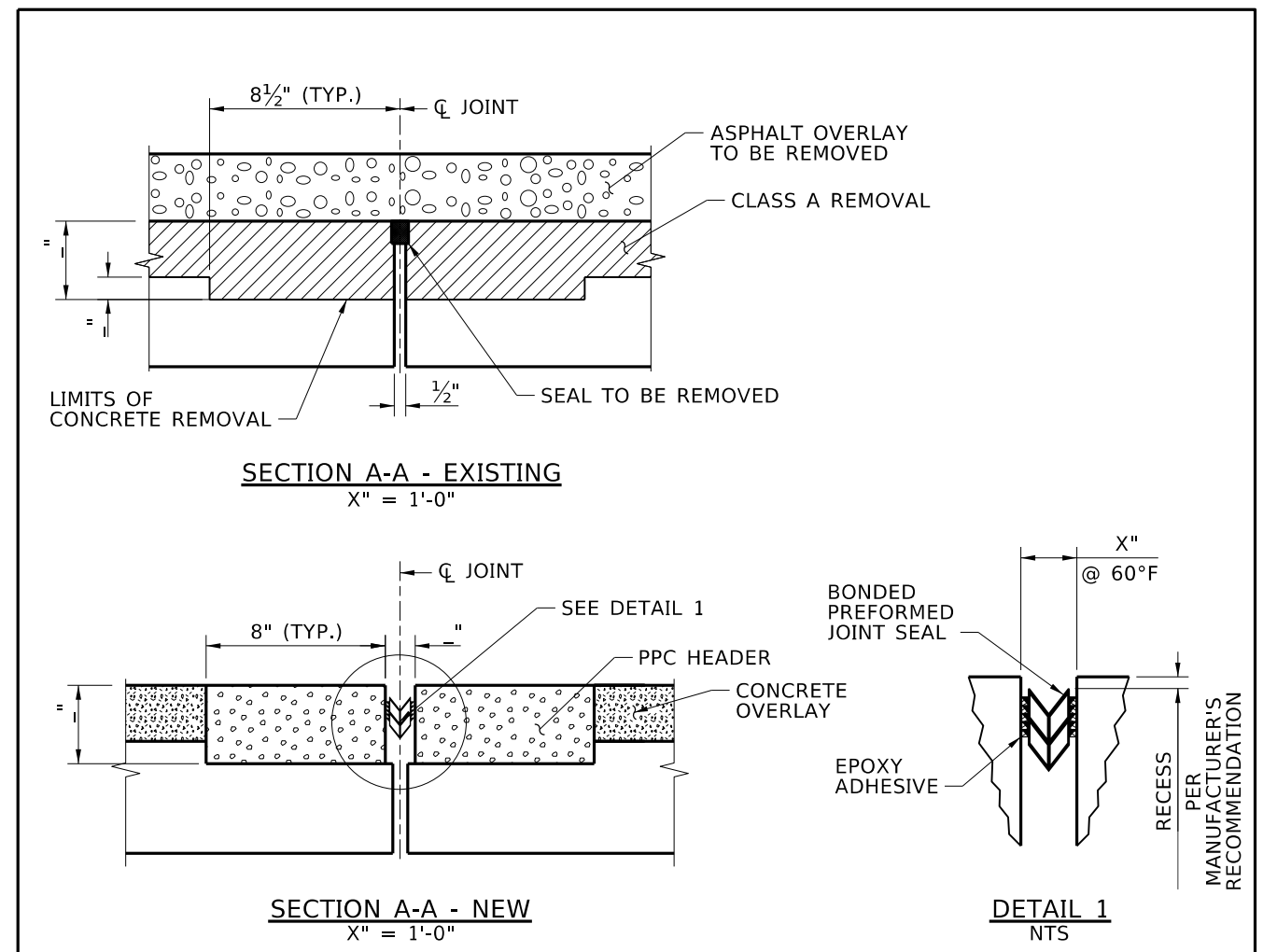

**TYPICAL JOINT DETAIL EXISTING AND NEW**  
NTS

NOTE TO DESIGNER: THIS SHEET IS INTENDED ONLY TO PROVIDE STANDARD DETAILS TO PROVIDE UNIFORMITY ON BRIDGE PLANS. MOVE DETAILS AS NECESSARY TO THE APPROPRIATE SHEETS.

REVISIONS				DESIGNED	SCALES SHOWN ARE FOR 11" X 17" PRINTS ONLY CADD FILE NAME Standards\Standard Bridge Drawings\817_6.DGN DRAWING DATE: DEC 2024	<b>IDAHO TRANSPORTATION DEPARTMENT</b> YOUR Safety→YOUR Mobility→YOUR Economic Opportunity APPROVED BY: BRIDGE ENGINEER MICHAEL T. JOHNSON DATE:
NO.	DATE	BY	DESCRIPTION	DESIGN CHECKED		
▲				DETAILED		
▲				DWG. CHECKED		
▲				CORRECTIONS		

ENGLISH PROJECT NO.	STANDARD REHAB DETAILS	BRIDGE PLANS	
	(REHAB & RETROFIT PROJECT) BRIDGE LRFD DESIGN MANUAL B17.6	BRIDGE KEY NO.	
		COUNTY	KEY NO.
		BRIDGE DWG. NO.	SHEET OF