

SECTION A-A

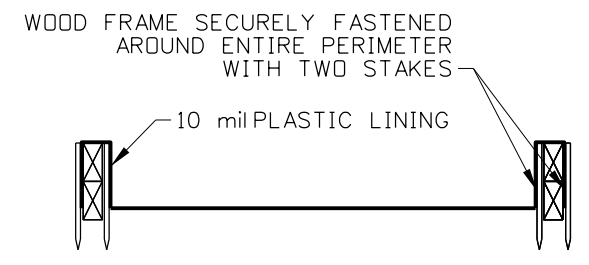

SECTION B-B

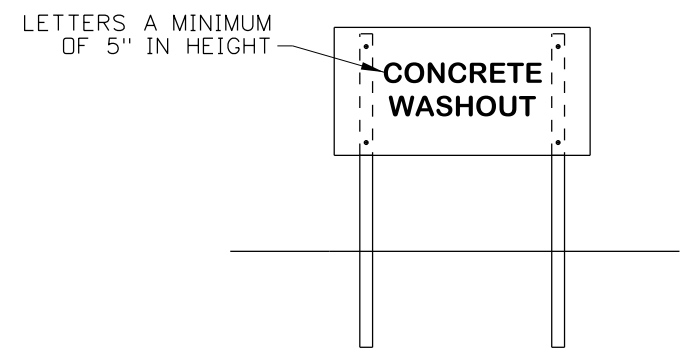

CONCRETE WASHOUT SIGN DETAIL
(SEE NOTE NO. 2)

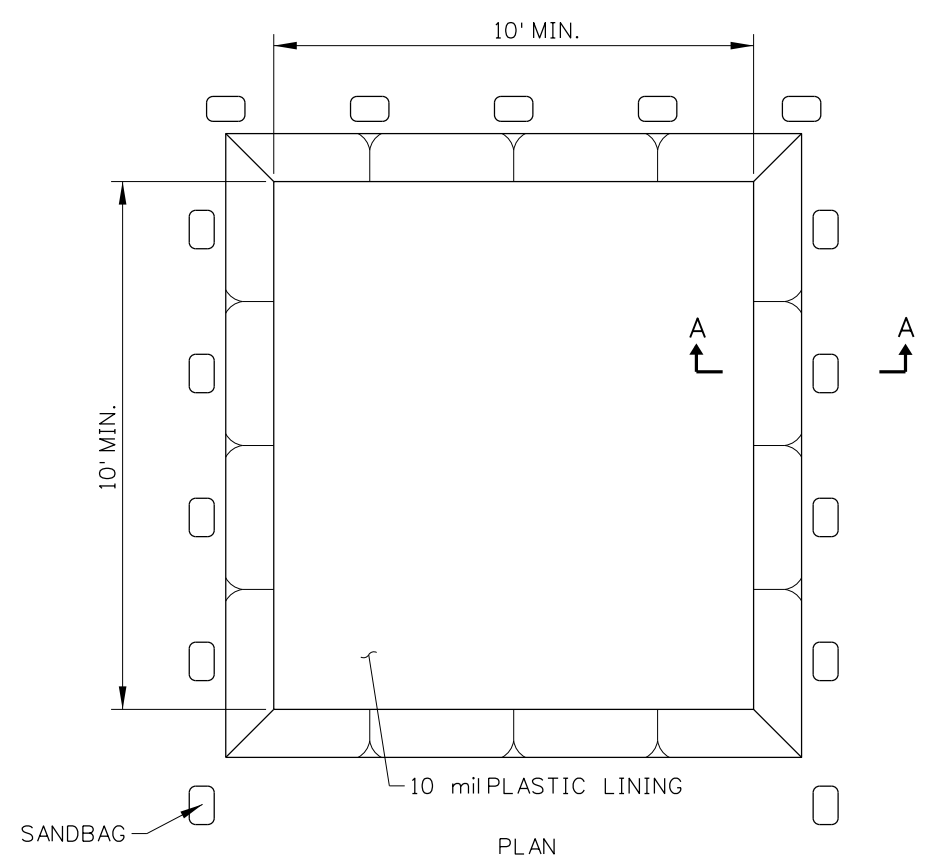

TYPE BELOW GRADE

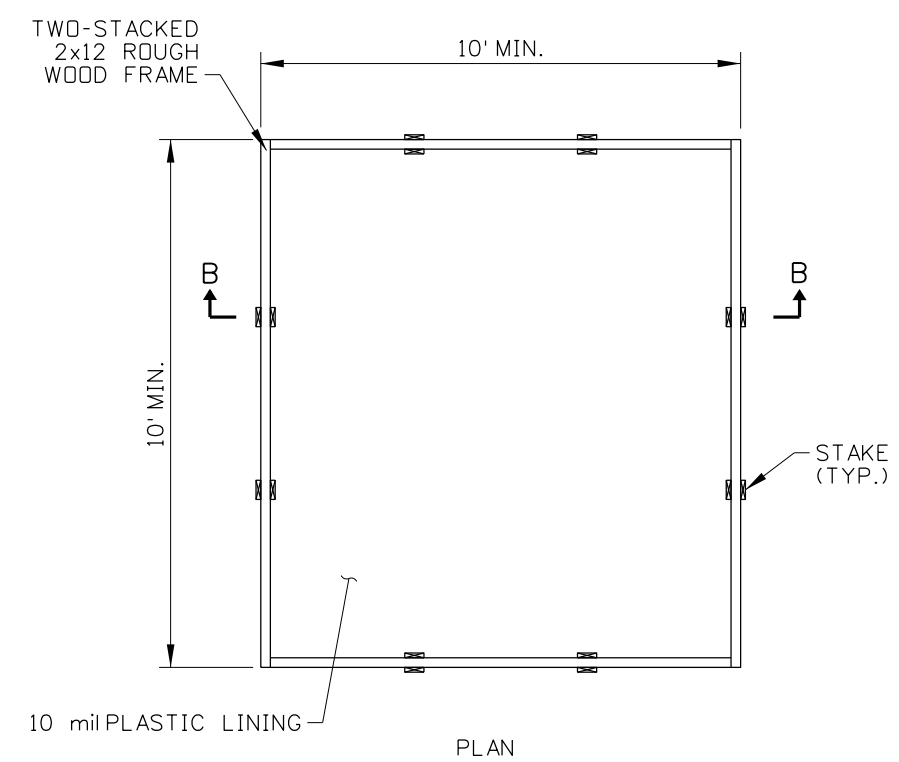

TYPE ABOVE GRADE

NOTES

1. USE THIS DRAWING IN CONJUNCTION WITH THE ITD BEST MANAGEMENT PRACTICES (BMP) MANUAL.
2. ACTUAL LAYOUT DETERMINED IN THE FIELD
3. INSTALL THE CONCRETE WASHOUT SIGN WITHIN 30 FEET OF THE TEMPORARY CONCRETE WASHOUT FACILITY.
4. USE OF PREFABRICATED TEMPORARY WASHOUT MAY ONLY BE USED ON APPROVAL BY THE ENGINEER.
5. NOT TO SCALE.

REVISIONS								
NO.	DATE	BY	NO.	DATE	BY	NO.	DATE	BY
1	11-13	RDL						

SCALES SHOWN ARE FOR 11" X 17" PRINTS ONLY
 CADD FILE NAME: 212-16_1113.dgn
 DRAWING DATE: OCTOBER, 2010

IDAHO TRANSPORTATION DEPARTMENT



BOISE IDAHO

ORIGINAL SIGNED BY: TOM COLE for
 HIGHWAYS PROGRAM OVERSIGHT ENGINEER

ORIGINAL SIGNED BY: TOM COLE
 CHIEF ENGINEER

STANDARD DRAWING

TEMPORARY CONCRETE WASHOUT

ORIGINAL STORED AT: ITD, Headquarters 3311 West State Boise, Idaho

English

STANDARD DRAWING NO. 212-16

SHEET 1 OF 1