

MODIFIED CRT TIMBER POST

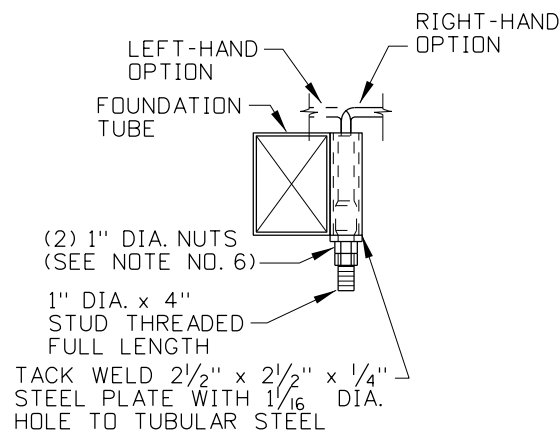

ANCHOR DETAIL
(SEE NOTE NO. 9)

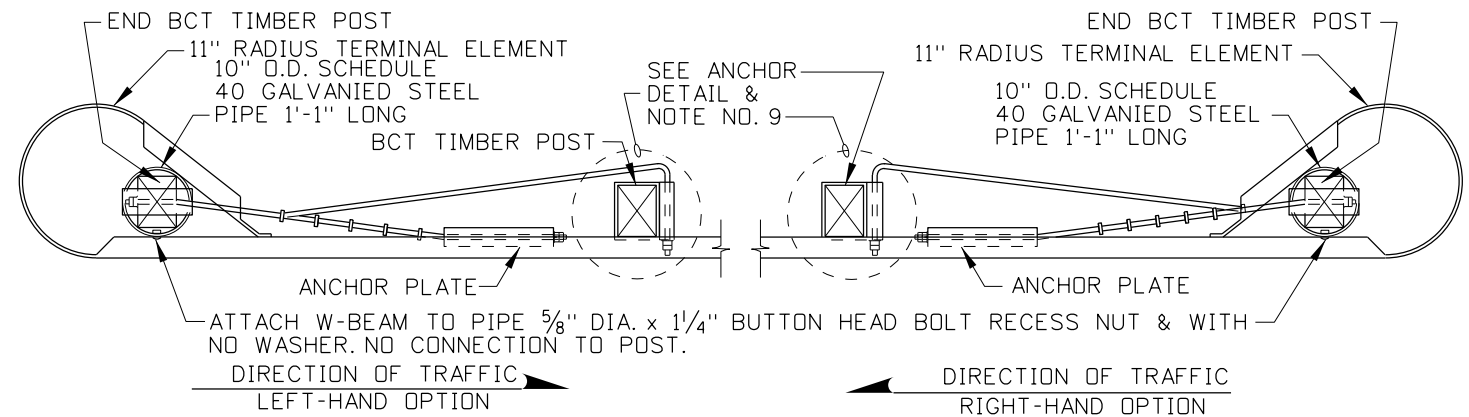

TABLE OF
MAXIMUM TAPERS

DESIGN SPEED	TAPER
70	15:1
60	13:1
50	11:1
40	9:1

PLACEMENT TABLE

DELTA ANGLE	RAIL RADIUS	NO. RAIL SECTIONS	NO. CRT POSTS	AREA FREE OF FIXED OBJECTS	
				L	W
75° -105°	8'	1	5	25'	15'
75° -105°	16'	2	7	30'	15'
75° -105°	24'	3	9	40'	20'
75° -80°	32'	3	9	40'	20'
>80° -100°	32'	4	11	40'	20'
>100° -105°	32'	5	13	40'	20'

NOTES

1. THE TYPE 8 TERMINAL SHALL ONLY BE USED OUTSIDE THE CLEAR ZONE OR WHEN THE APPROACH ROADWAY SPEED IS 35 MPH OR LESS. OTHERWISE AN APPROPRIATE NCHRP 350 TERMINAL IS REQUIRED.
2. THE GUARDRAIL ALONG THE APPROACH ROADWAY MAY BE ANGLED 15° TO EITHER SIDE OF THE PERPENDICULAR AXIS TO THE MAIN ROADWAY. HOWEVER, FLARE RATES ALONG ROADWAYS WITH 35 MPH OR GREATER SPEEDS MUST FOLLOW STANDARD TAPER RATES (SEE "TABLE OF MAXIMUM TAPERS").
3. THE ROADWAY IN FRONT THE CURVED PORTION OF THE TERMINAL SHALL BE 15:1 OR FLATTER. GRADE TERRAIN TO A 10:1 SLOPE OR FLATTER FOR 2' BEYOND THE GUARDRAIL POST, THEN A 2:1 OR FLATTER SLOPE. A 6:1 OR FLATTER SLOPE IS DESIRABLE. IF THE FILL HEIGHT IS GREATER THAN 30' OTHER SOLUTIONS SHOULD BE CONSIDERED. AN AREA FREE OF FIXED OBJECTS SHALL BE MAINTAINED BEHIND THE GUARDRAIL.
4. THIS DRAWING REQUIRES STANDARD DRAWING 612-1 AND IS SUBJECT TO THE W-BEAM GUARDRAIL INSTALLATION REQUIREMENTS AND HARDWARE/ACCESSORY SPECIFICATIONS.
5. ALL TERMINAL HARDWARE ITEMS SHALL MEET THE SPECIFICATIONS IN THE "A GUIDE TO STANDARDIZED HIGHWAY BARRIER HARDWARE" (CURRENT EDITION). ALL WELDING SHALL MEET THE REQUIREMENTS OF THE AMERICAN WELDING SOCIETY.
6. WHEN FASTENING THE CABLE ENDS THE OUTSIDE NUTS SHALL BE TORQUED AGAINST INSIDE NUTS A MINIMUM OF 100 FT.-LBS.
7. ALL CURVED GUARDRAIL SHALL BE SHOP BENT, FIELD BENDING WILL NOT BE ALLOWED.
8. ALL CURVED RAIL SECTIONS SHALL BE 12'-6" IN LENGTH AND BOLTED TO THE POSTS ONLY AT THE LAPS.
9. THE ANCHOR CABLE FROM POST #1 TO POST #2 MUST BE ATTACHED ON THE FAR SIDE OF THE FOUNDATION TUBE FOR LEFT-HAND INSTALLATIONS.
10. NOT TO SCALE.

POST TABLE

POST	DIMENSIONS	TYPE
①	6" x 8" x 6"	CRT
②	5 1/2" x 7 1/2" x 42 1/2"	BCT

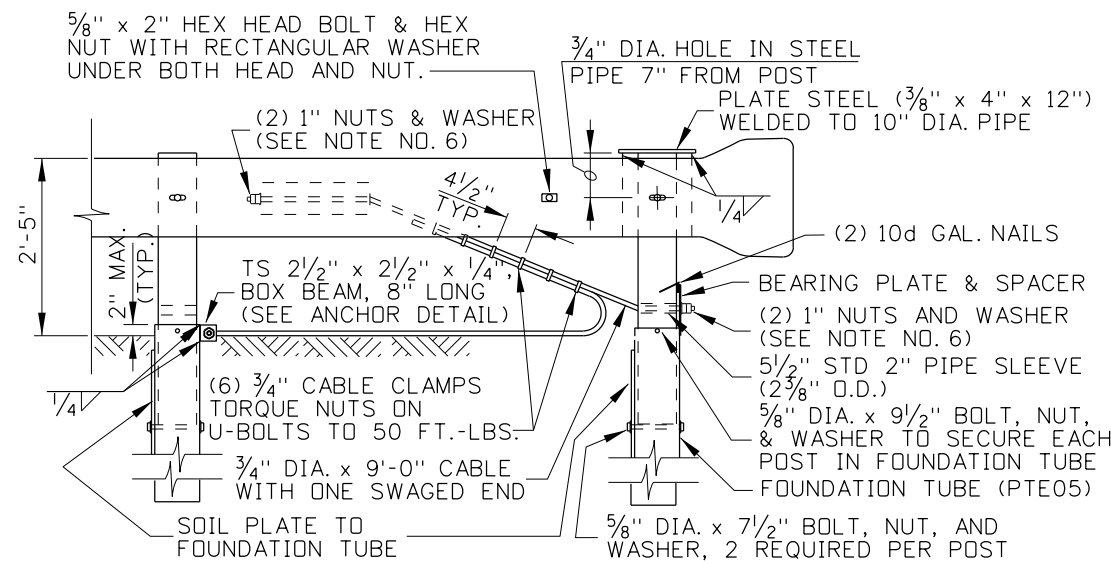

ELEVATION
TERMINAL TYPE 8
(RIGHT-HAND OPTION SHOWN)

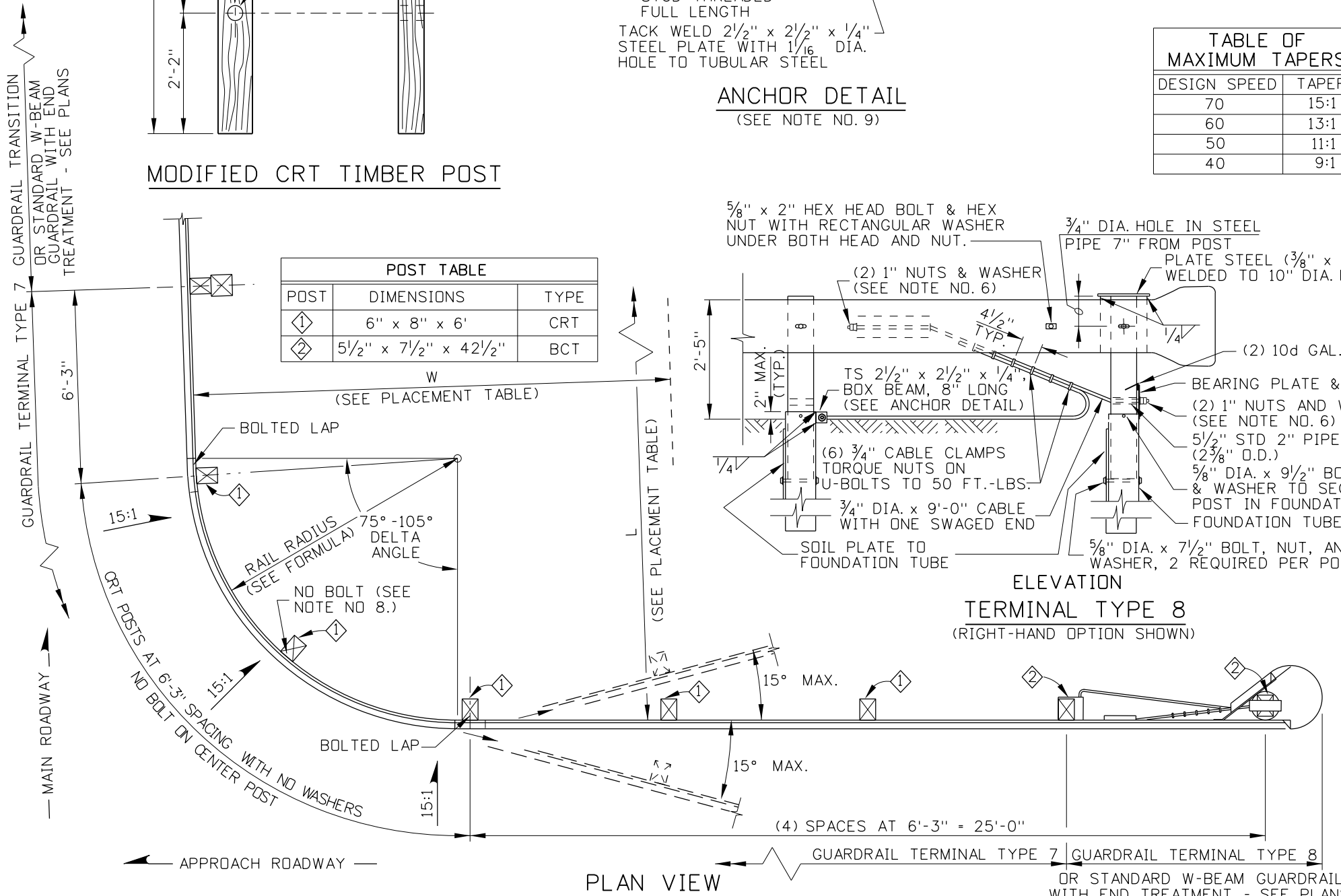

PLAN VIEW

REVISIONS

NO.	DATE	BY	NO.	DATE	BY	NO.	DATE	BY
1	05-90	GB	6	05-06	MSM			
2	04-93	MSM	7	11-06	MSM			
3	04-99	MSM	8	09-10	MGL			
4	03-03	MSM						
5	12-04	MSM						

SCALES SHOWN ARE FOR 11" X 17" PRINTS ONLY
CADD FILE NAME: 612-3_1010.dgn
DRAWING DATE: MAY, 1989

IDAHO
TRANSPORTATION
DEPARTMENT



BOISE IDAHO

ORIGINAL SIGNED BY: LOREN THOMAS
ASSISTANT CHIEF ENGINEER (DEVELOPMENT)
ORIGINAL SIGNED BY: TOM COLE
CHIEF ENGINEER

STANDARD DRAWING

GUARDRAIL TERMINAL
TYPES 7 & 8

REQUIRES STD. DWG. 612-1

English

STANDARD DRAWING NO.

612-3

SHEET 1 OF 1

ORIGINAL STORED AT: ITD, Headquarters 3311 West State Boise, Idaho

