

4" x 3" POST DETAILS

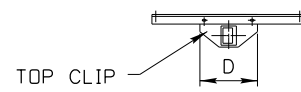

SECTION BB-BB

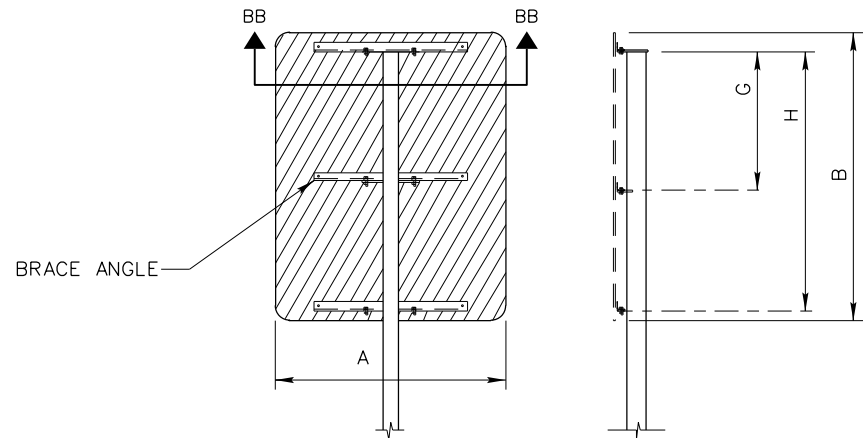

POST AND BRACE ANGLES
4" x 3", 5" x 5", 6" x 6" POSTS

SIGN DESCRIPTION	SIGN SIZE		C	D	E	F	G	H	WEIGHT IN LBS.
	A	B							
STOP	36"	36"	32"	12"	11"	5"	30"	N/A	14.80
	48"	48"	42"	12"	16"	5"	20"	N/A	19.40
YIELD	60" TRIANGLE		48"	12"	19"	5"	N/A	N/A	13.90
			12"	12"	1"	5"	35"		
SQUARE AND RECTANGULAR SIGNS	36"	48"	32"	12"	11"	5"	42"	N/A	14.80
	48"	60"	32"	12"	11"	5"	27"	54"	22.20
	36"	36"	32"	12"	11"	5"	30"	N/A	14.80
	48"	48"	44"	12"	17"	5"	42"	N/A	22.30
	48"	36"	32"	12"	11"	5"	30"	N/A	14.80
	72"	36"	62"	12"	26"	5"	18"	N/A	28.60
	72"	48"	62"	12"	26"	5"	30"	N/A	28.60
	48"	30"	32"	12"	11"	5"	24"	N/A	14.80
	72"	30"	62"	12"	26"	5"	24"	N/A	28.60
WARNING & AUXL. SIGNS	36"	24"	32"	12"	11"	5"	18"	N/A	14.80
	36"	30"	32"	12"	11"	5"	24"	N/A	14.80
	36"	18"	*	*	*	*	*	N/A	12.00
	48"	18"	*	*	*	*	*	N/A	19.40
WARNING	24"	24"	*	*	*	*	*	N/A	12.00
	36"	DIAMOND	26"	12"	8"	5"	16"	N/A	12.00
	48"	DIAMOND	42"	12"	16"	5"	20"	N/A	19.40
WARNING LARGE ARROW	48"	24"	42"	12"	16"	5"	18"	N/A	19.40
	60"	36"	44"	12"	17"	5"	30"	N/A	20.40
JUNCTION ASSEMBLY	21"	15"	*	*	*	*	POST TOP CLIP NOT REQ'D-COVER PLATE ONLY		
	2-24" ROUTE MARKERS		27"	12"	8 1/2"	5"	20"	38"	12.50
SINGLE CARDINAL DIRECT'L ASSY.	30"	15"	26"	12"	8"	5"	N/A	N/A	15.20
	36"	36"	26"	12"	8"	5"	13 1/2"	N/A	
JUNCTION ASSEMBLY	21"	15"	*	*	*	*	POST TOP CLIP NOT REQ'D-COVER PLATE ONLY		
	3-24" ROUTE MARKERS		54"	12"	21"	5"	20"	38"	25.00

- NOTES:
- WEIGHTS OF BRACE ANGLES DO NOT INCLUDE GALVANIZING.
 - ALL BRACE ANGLES SHALL BE 1 3/4" x 1 3/4" x 1/4" AT 2.77 LBS./FT.
 - THE AUXILIARY SIGNS SHALL BE ATTACHED BY DRILLING THE POST WITH TWO HOLES AND FLUSH MOUNT THE SIGN TO THE FACE OF THE POST.
 - REFER TO STANDARD DRAWING 616-6.
 - WHEN ONLY ONE BRACE IS REQUIRED, PLACE IN THE CENTER OF THE SIGN.

POST DETAILS FOR 4"x3" POSTS						
SIGN DESCRIPTION	SIGN SIZE		G	H	J	K
	A	B				
STOP	30"	30"	25 1/4"	N/A	N/A	28 1/4"
	36"	36"	31 1/4"	N/A	N/A	34 1/4"
YIELD	36" TRIANGLE		25 1/4"	N/A	N/A	30 1/4"
SQUARE AND RECTANGULAR SIGNS	12"	30"	25 1/4"	N/A	N/A	28 1/4"
	24"	36"	N/A	N/A	N/A	
	24"	30"	19 1/4"	N/A	N/A	22 1/4"
	24"	30"	25 1/4"	N/A	N/A	28 1/4"
	30"	30"	25 1/4"	N/A	N/A	28 1/4"
	30"	36"	31 1/4"	N/A	N/A	34 1/4"
	36"	24"	19 1/4"	N/A	N/A	22 1/4"
WARNING	18"	DIAMOND	21 1/4"	N/A	N/A	23 1/2"
	30"	DIAMOND	31 1/4"	N/A	N/A	37 1/4"
WARNING & AUXL. SIGNS	30"	DIAMOND	31 1/4"	N/A	N/A	56 1/4"
NO PASS. ZONE	18"	18"	N/A	39 3/4"	54 3/4"	21 1/2"
TRAIL BLAZER ASSEMBLY (ASSY.)	48"	36"	19 1/4"	N/A	N/A	21 1/2"
	24"	12"	10 1/4"	N/A	N/A	
	24"	24"	N/A	15 3/4"	33 3/4"	51 1/4"
ADV. ROUTE MARKER ASSY.	21"	15"	N/A	N/A	N/A	
	24"	24"	19 1/4"	N/A	N/A	38 1/4"
SINGLE JCT. ASSY.	24"	15"	N/A	24 3/4"	36 3/4"	
	24"	15"	N/A	24 3/4"	36 3/4"	39 3/4"
HOSPITAL, CAMPING ASSY.	24"	24"	N/A	18 3/4"	36 3/4"	
	24"	24"	19 1/4"	N/A	N/A	29 1/4"
	24"	6"	N/A	24 3/4"	27 3/4"	

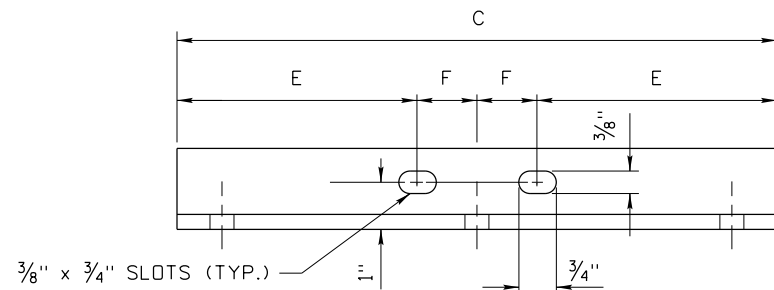

NOTE:
CENTER HOLES IN THE BRACE ANGLES ARE REQUIRED ONLY FOR THOSE SIGNS WHERE "A" IS 72" OR GREATER.

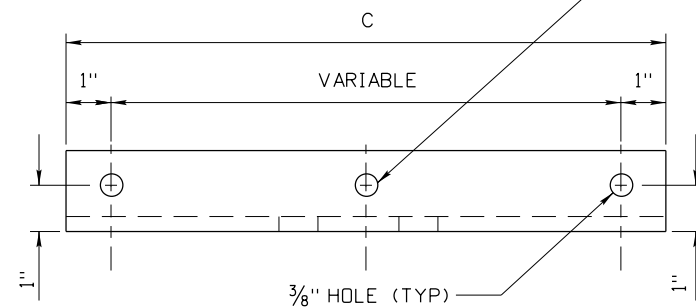

BRACE ANGLE DETAIL

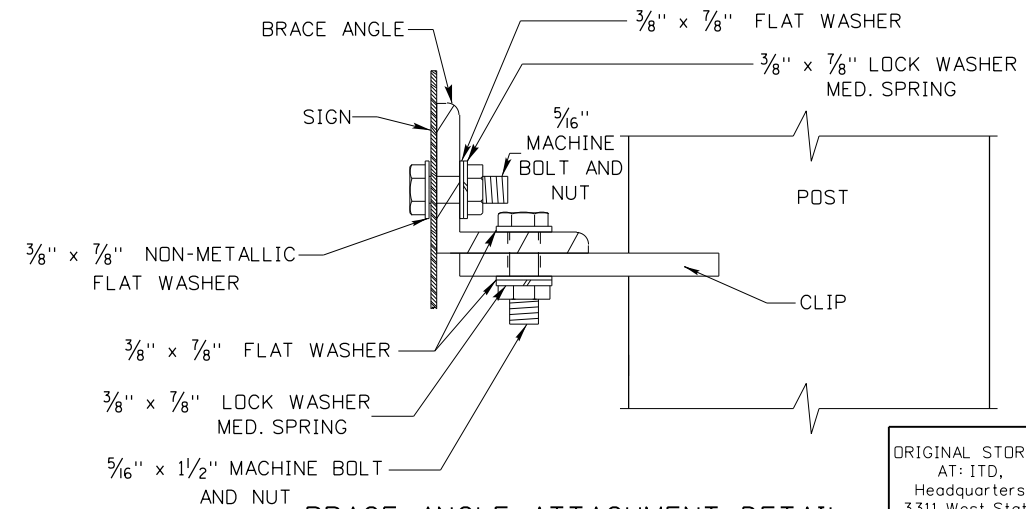

BRACE ANGLE ATTACHMENT DETAIL

ORIGINAL STORED AT: ITD, Headquarters 3311 West State Boise, Idaho

REVISIONS							
NO.	DATE	BY	NO.	DATE	BY	NO.	DATE
1	08-96	HEB	6	12-13	HEB		
2	12-01	NQB					
3	12-07	HEB					
4	07-10	HEB					
5	09-11	HEB					

SCALES SHOWN ARE FOR 11" X 17" PRINTS ONLY
CADD FILE NAME: 616-16_1213.dgn
DRAWING DATE: DECEMBER, 2007

IDAHO TRANSPORTATION DEPARTMENT

BOISE IDAHO

ORIGINAL SIGNED BY: RYAN LANCASTER for
DESIGN/TRAFFIC SERVICES ENGINEER

STANDARD DRAWING

B POST AND BRACE ANGLE DETAIL

English
STANDARD DRAWING NO.
616-16
SHEET 1 OF 2

PROFESSIONAL ENGINEER
REGISTERED
CARL D. MAIN
STATE OF IDAHO
DECEMBER 6, 2007

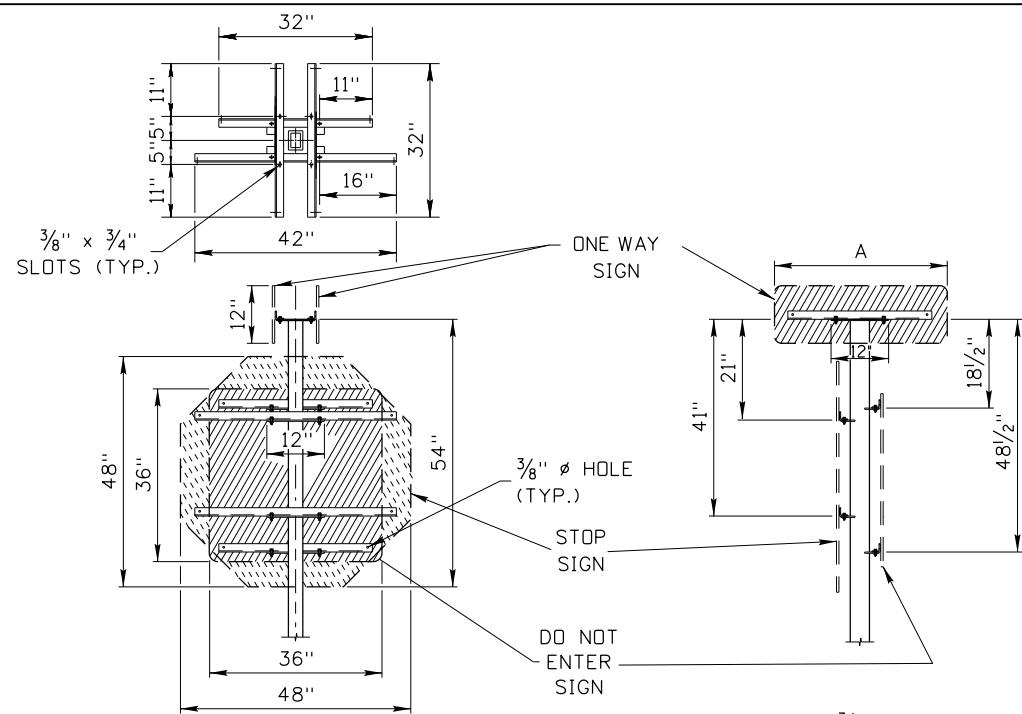

WEIGHT OF BRACE ANGLES = 48.92 lbs.

RAMP TERMINAL ASSEMBLY "A"

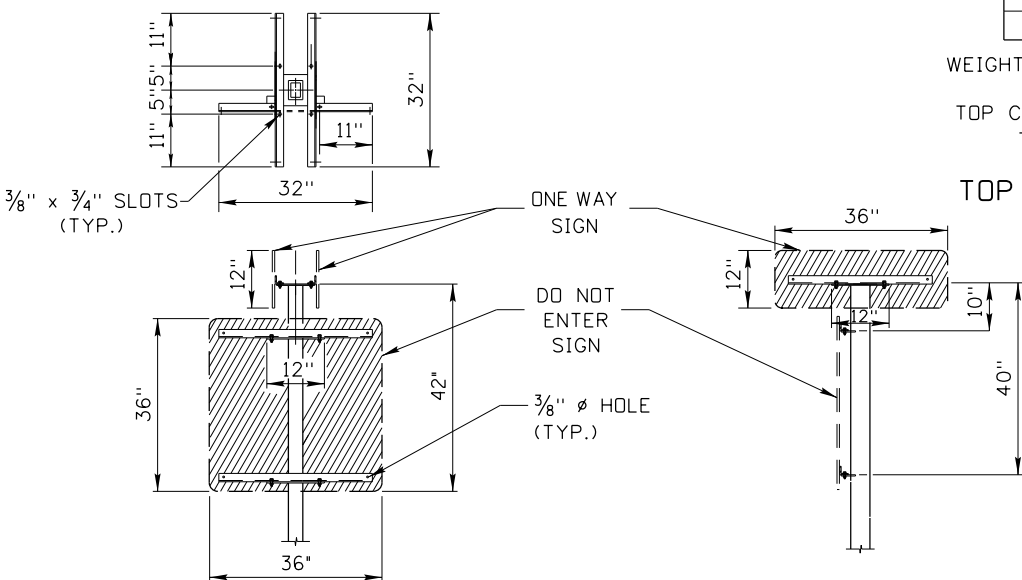

WEIGHT OF BRACE ANGLES = 29.56 lbs.

RAMP TERMINAL ASSEMBLY "B"

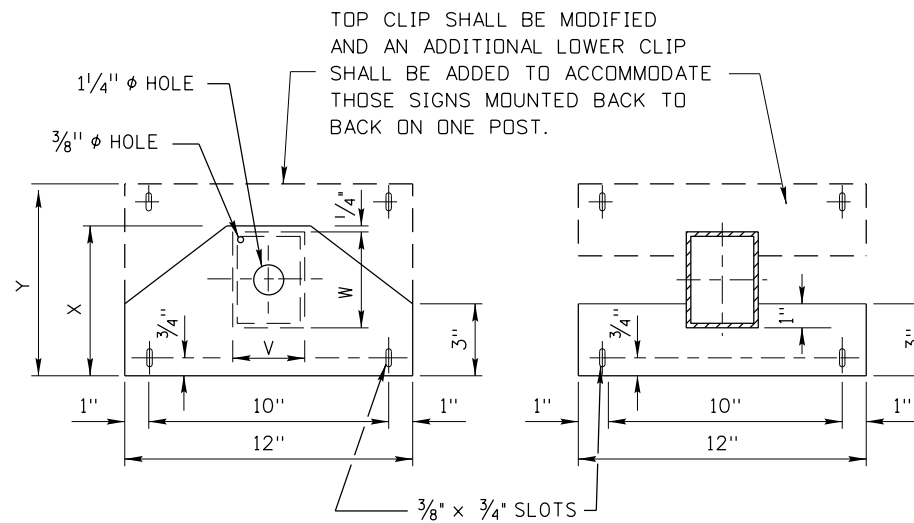

B-2 POST TOP CLIP DETAIL TOP VIEW
B-2 POST LOWER CLIP DETAIL SECTION A-A

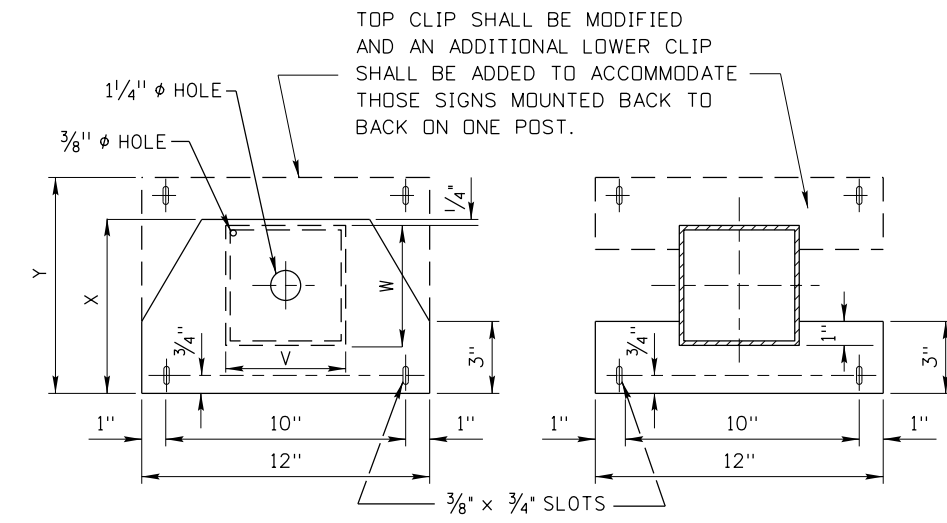

B-3 & B-4 POST TOP CLIP DETAIL TOP VIEW
B-3 & B-4 POST LOWER CLIP DETAIL SECTION A-A

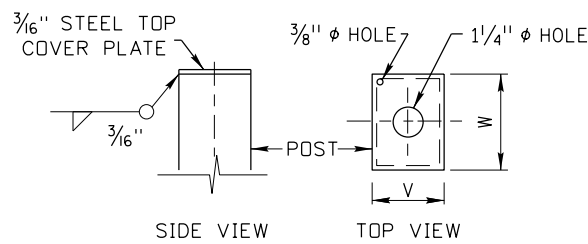

Post Type	Post		Weight, in Lbs. for cover plate
	V	W	
B-2	3"	4"	0.55
B-3	4"	6"	1.25
B-4	4"	8"	1.80

WEIGHTS DO NOT INCLUDE GALVANIZING

TOP COVER PLATE IS REQUIRED WHEN THERE IS NOT A TOP CLIP

TOP COVER PLATE DETAILS

Post Type	Post		Top Clip	
	V	W	X	Y
B-2	3"	4"	6 $\frac{1}{4}$ "	8"

Post Type	Post		Top Clip	
	V	W	X	Y
B-3	5"	5"	7 $\frac{1}{4}$ "	9"
B-4	6"	6"	8 $\frac{1}{4}$ "	10"

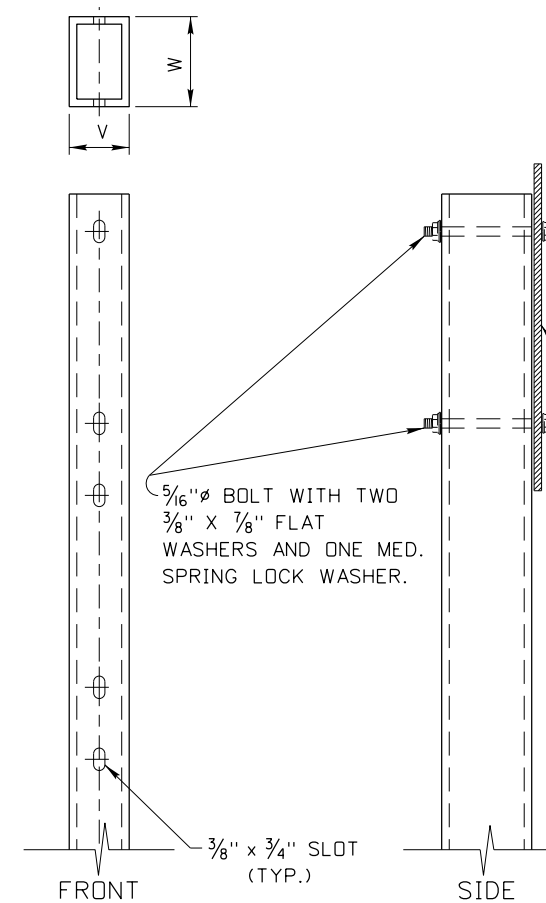

TYPE B-2 POST

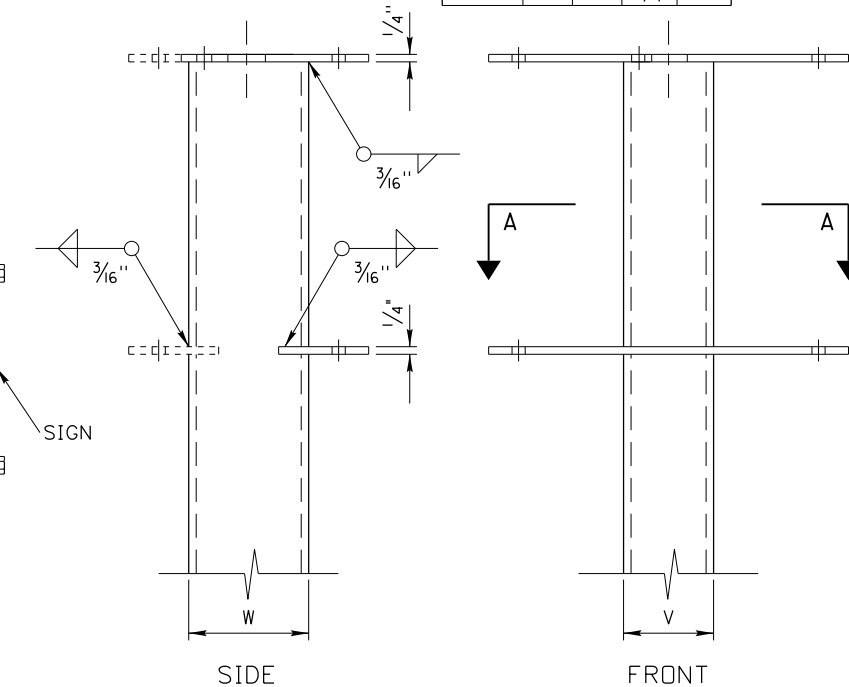

TYPE B-2, B-3, B-4 POSTS

WEIGHT SCHEDULE			
Post Type	Wt. in Lbs. for lower clip - each	Weight, in Lbs. for top clip - each	Weight for modified top clip - each
B-2	2.55	5.32	6.82
B-3	2.55	6.18	7.67
B-4	2.55	7.03	8.52

WEIGHTS DO NOT INCLUDE GALVANIZING

NOTES:

- REFER TO STANDARD DRAWING 616-6.
- POST WEIGHTS SHALL INCLUDE THE WEIGHT OF THE CLIPS OR COVER PLATES IF USED.

ORIGINAL STORED AT: ITD, Headquarters 3311 West State Boise, Idaho

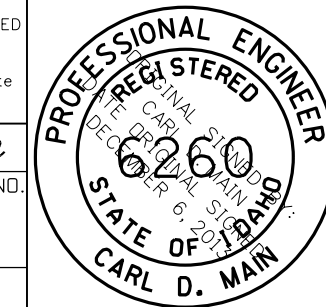

REVISIONS							
NO.	DATE	BY	NO.	DATE	BY	NO.	DATE
1	08-96	HEB	6	09-11	HEB		
2	02-98	HEB	7	12-13	HEB		
3	12-01	NQB					
4	12-07	HEB					
5	07-10	HEB					

SCALES SHOWN ARE FOR 11" X 17" PRINTS ONLY
CADD FILE NAME: 616-16_1213.dgn
DRAWING DATE: DECEMBER, 2007

IDAHO TRANSPORTATION DEPARTMENT
BOISE IDAHO

ORIGINAL SIGNED BY: RYAN LANCASTER for DESIGN/TRAFFIC SERVICES ENGINEER

STANDARD DRAWING
B POST AND BRACE ANGLE DETAIL

English
STANDARD DRAWING NO. 616-16
SHEET 2 OF 2