

TYPE 1 & 5 MONO-DIRECTIONAL SINGLE DELINEATOR  
 TYPE 2 & 6 MONO-DIRECTIONAL DOUBLE DELINEATOR  
 TYPE 3 & 7 BI-DIRECTIONAL SINGLE DELINEATOR  
 TYPE 4 & 8 BI-DIRECTIONAL DOUBLE DELINEATOR

**DELINEATOR TYPES**

TYPE 9 NOT SHOWN  
 TYPE 9 SHAPE VARIES

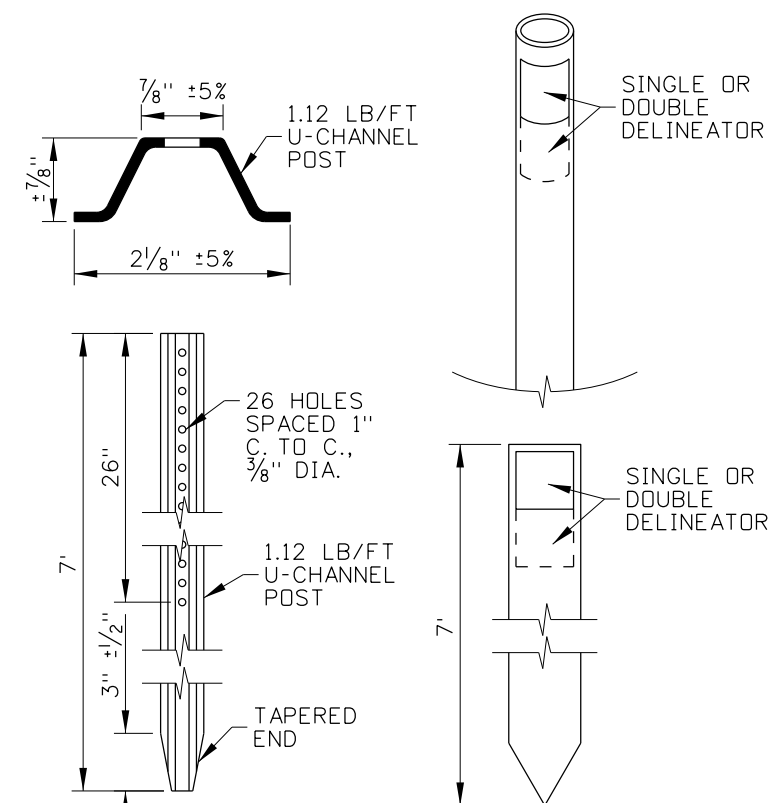

**RIGID POST**  
 (SEE NOTE NO. 6)

**FLEXIBLE POST**  
 PROPRIETARY POSTS MAY DIFFER FROM THOSE SHOWN  
 (SEE NOTE NO. 6)

HORIZONTAL CURVE SPACING TABLE				
RADIUS OF CURVE (FEET)	APPROXIMATE SPACING ON CURVE (FEET)	1st SPACE BEYOND PCS, PSC, PC, PT (FEET)	2nd SPACE BEYOND PCS, PSC, PC, PT (FEET)	3rd SPACE BEYOND PCS, PSC, PC, PT (FEET)
< 300	25	50	75	150
300-699	50	100	150	300
700 - 1,199	75	150	225	300
1,200 - 2,499	100	200	300	300
2,500 - 4,499	150	300	300	300
4,500 - 6,999	200	300	300	300
7,000 - 10,000	250	300	300	300
> 10,000	300	300	300	300

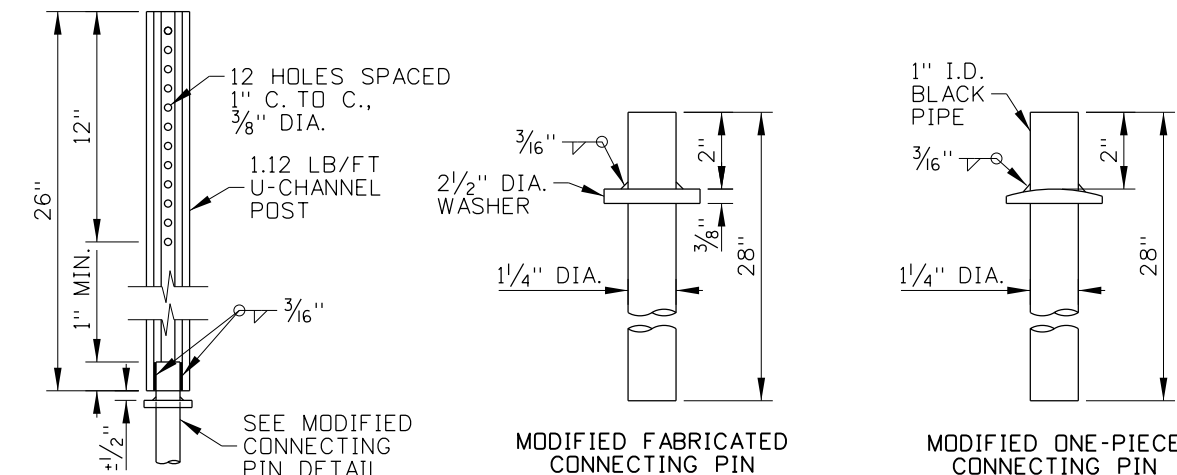

**STUB POST**  
 FOR USE WITH TYPE 5, 6, 7, OR 8 DELINEATORS

**MODIFIED FABRICATED CONNECTING PIN**  
**MODIFIED ONE-PIECE CONNECTING PIN**  
 FOR USE WITH TYPE 5, 6, 7, OR 8 DELINEATORS  
 (SEE STANDARD DRAWINGS G-2-A-1 & G-2-A-2)

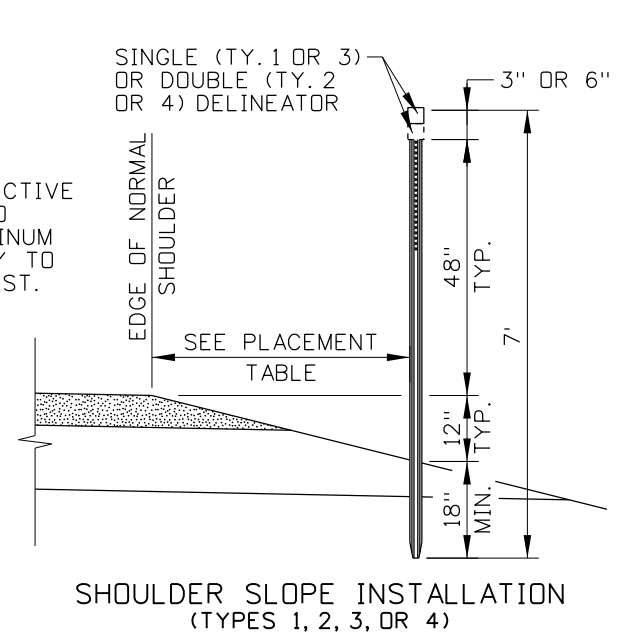

**SHOULDER SLOPE INSTALLATION**  
 (TYPES 1, 2, 3, OR 4)

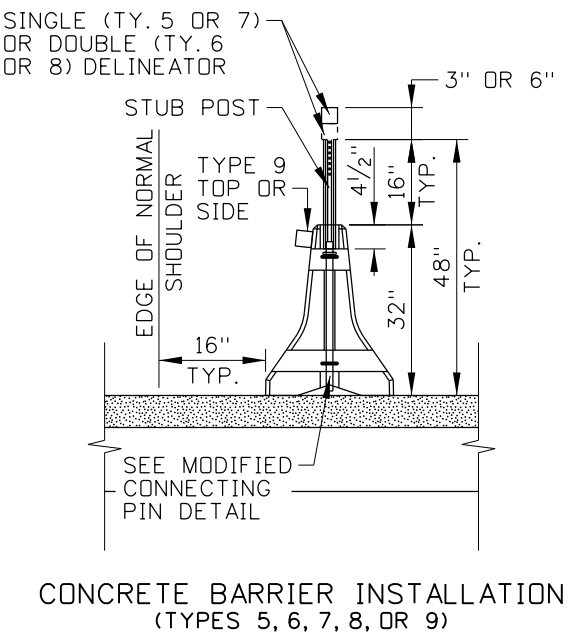

**CONCRETE BARRIER INSTALLATION**  
 (TYPES 5, 6, 7, 8, OR 9)

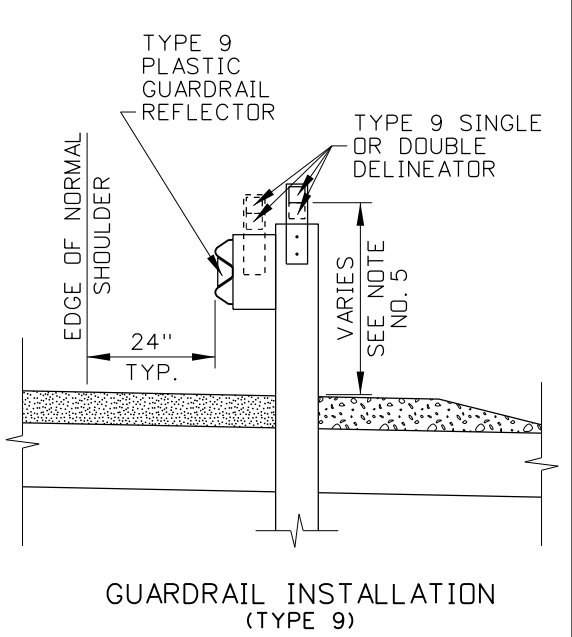

**GUARDRAIL INSTALLATION**  
 (TYPE 9)

**DELINEATOR INSTALLATIONS**

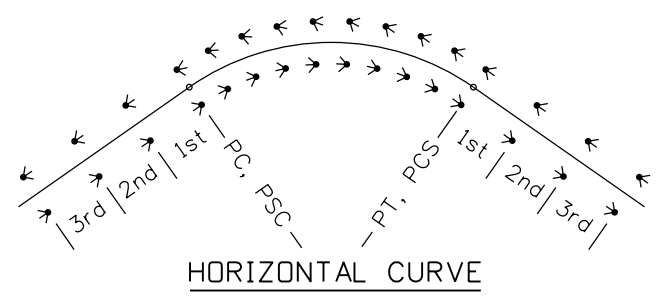

**HORIZONTAL CURVE**

PLACEMENT TABLE	
SHOULDER	OFFSET
2:1 SLOPE	2'
4:1 SLOPE	4'
6:1 OR FLATTER	6' TO 8'
CURB SECTION	6'
GUARDRAIL OR CONCRETE BARRIER	VARIES

**NOTES**

- ENSURE THAT THE DELINEATOR COLOR MATCHES THE COLOR OF THE ADJACENT EDGE LINE. USE RED DELINEATORS ON TRUCK ESCAPE RAMPS OR ON THE REVERSE SIDE OF A DELINEATOR TO INDICATE TRAVEL IN THE WRONG DIRECTION ON DIVIDED OR ONE-WAY HIGHWAYS.
- WHEN USED, SPACE DELINEATORS 528 FEET (0.1 MI.) APART ON MAINLINE TANGENT SECTIONS. SPACE DELINEATORS 100 FEET APART ON RAMP TANGENT SECTIONS. DELINEATE DECELERATION TRANSITION TAPERS WITH DOUBLE DELINEATORS AND SPACE TWO TIMES THE TAPER RATE, OR A MAXIMUM DISTANCE OF 100 FEET. ACCELERATION TRANSITION TAPERS MAY ALSO BE DELINEATED. REDUCE DELINEATOR SPACING ON CREST VERTICAL CURVES.
- DELINEATE GUARDRAIL AND CONCRETE BARRIERS. SPACING MAY BE REDUCED ON GUARDRAIL AND CONCRETE BARRIER TO FORM A CONTINUOUS OR NEARLY CONTINUOUS "RIBBON" OF DELINEATION.
- SPACE DELINEATORS ON CURVES IN ACCORDANCE WITH THE HORIZONTAL CURVE SPACING TABLE.
- MEASURE DELINEATOR HEIGHT VERTICALLY FROM THE BOTTOM OF THE LOWEST REFLECTIVE DEVICE TO THE ELEVATION OF THE EDGE OF NORMAL SHOULDER. DELINEATORS ATTACHED TO GUARDRAIL, GUARDRAIL POSTS, OR CONCRETE BARRIER MAY BE INSTALLED LOWER THAN 48".
- RIGID OR FLEXIBLE POSTS MAY BE USED FOR TYPES 1, 2, 3, AND 4. PROJECT PLANS MAY INDICATE WHICH POST TYPE TO USE. ON CONCRETE BARRIERS, USE TYPE 5, 6, 7, OR 8 DELINEATORS ON STUB POSTS OR TYPE 9 DELINEATORS. ON GUARDRAIL, USE TYPE 9 DELINEATORS OR TYPE 1, 2, 3, OR 4 RIGID OR FLEXIBLE POST DELINEATORS BETWEEN GUARDRAIL POSTS.
- WHEN UNIFORM SPACING IS INTERRUPTED BY DRIVEWAYS, INTERSECTIONS, OR OTHER FEATURES, RELOCATE THE DELINEATOR IN EITHER DIRECTION FOR A DISTANCE NOT EXCEEDING ONE QUARTER OF THE UNIFORM SPACING. DELINEATORS STILL FALLING WITHIN SUCH FEATURES MAY BE ELIMINATED.
- TYPE 9 DELINEATORS VARY IN SHAPE AND MAY BE ATTACHED TO CONCRETE BARRIER, TO GUARDRAIL POSTS, OR TO W-BEAM GUARDRAIL.
- DRAWINGS NOT TO SCALE.

ORIGINAL STORED AT: ITD, Headquarters 3311 West State Boise, Idaho

REVISIONS							
NO.	DATE	BY	NO.	DATE	BY	NO.	DATE
1	06-05	MSM					
2	11-11	TEM					
3	04-14	RDL					
4	03-15	PJF					
5	05-16	RDL					

SCALES SHOWN ARE FOR 11" X 17" PRINTS ONLY

CADD FILE NAME: 617-1\_0516.dgn

DRAWING DATE: DECEMBER, 2002

**IDAHO TRANSPORTATION DEPARTMENT**

BOISE IDAHO

ORIGINAL SIGNED BY: JESSE BARRUS  
 DESIGN/TRAFFIC SERVICES ENGINEER

STANDARD DRAWING

**DELINEATORS**

**English**

STANDARD DRAWING NO. **617-1**

SHEET 1 OF 1

ORIGINAL SIGNED BY: RYAN D. LANCASTER  
 DATE ORIGINAL SIGNED: MAY 12, 2016