

PEDESTRIAN PUSHBUTTON POLE

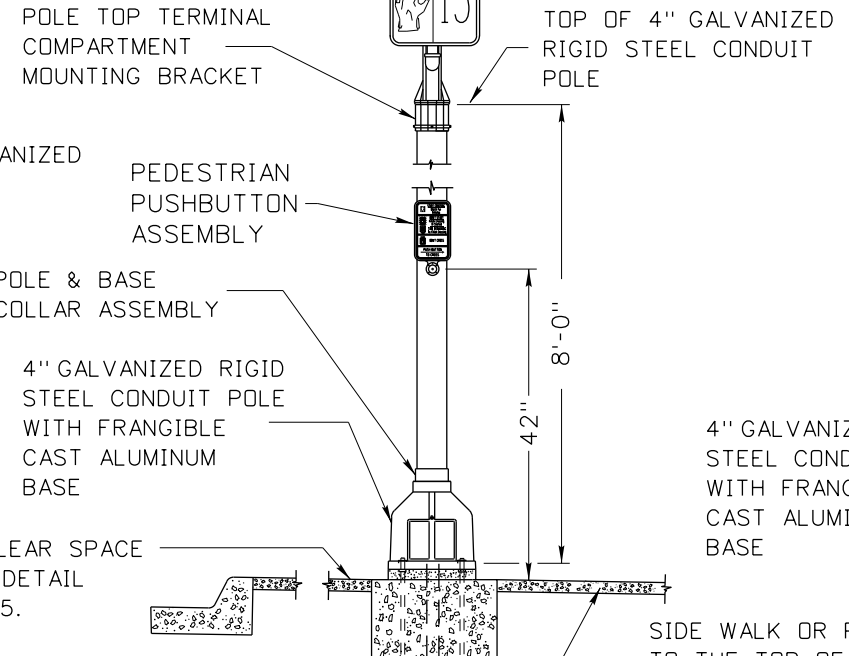

PEDESTRIAN SIGNAL

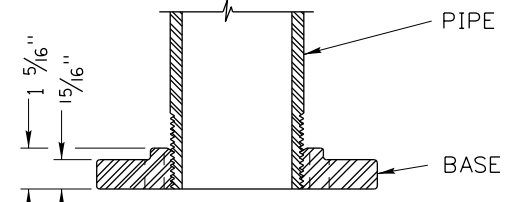

SECTION A-A

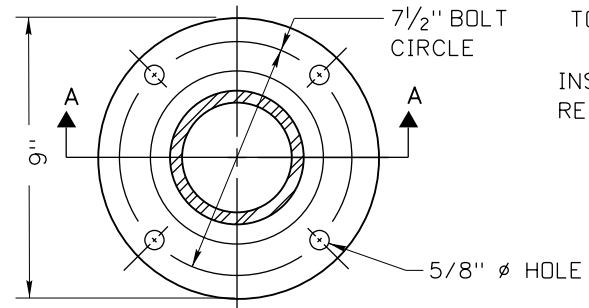

FRANGIBLE CAST IRON PIPE FLANGE

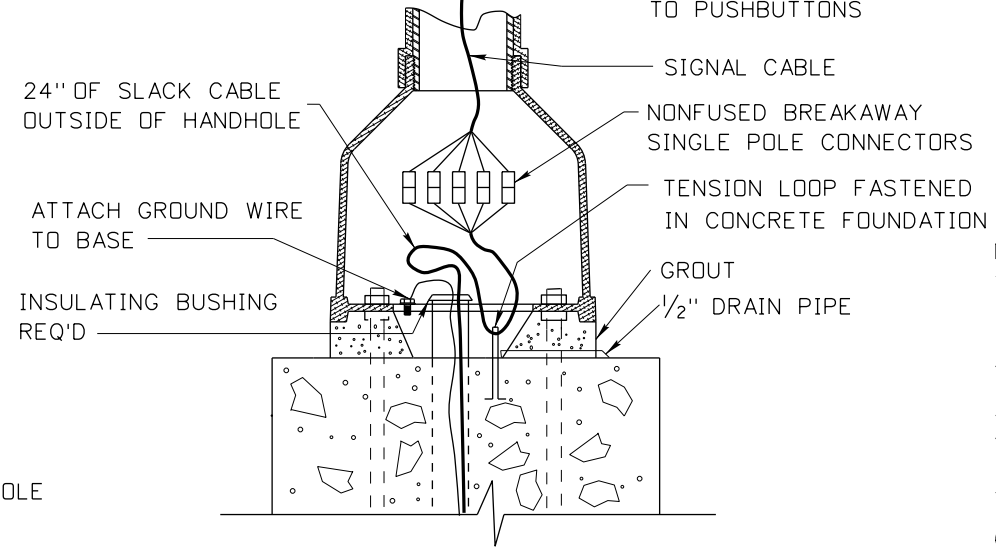

TYPICAL SIGNAL PEDESTAL CONNECTOR INSTALLATION

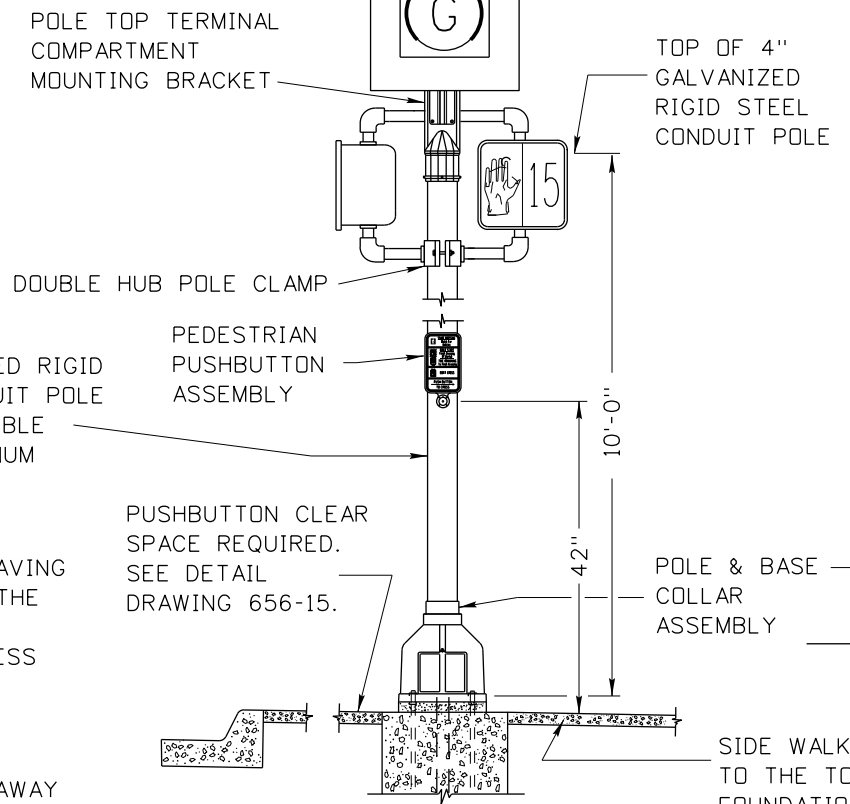

VEHICLE AND PEDESTRIAN SIGNAL

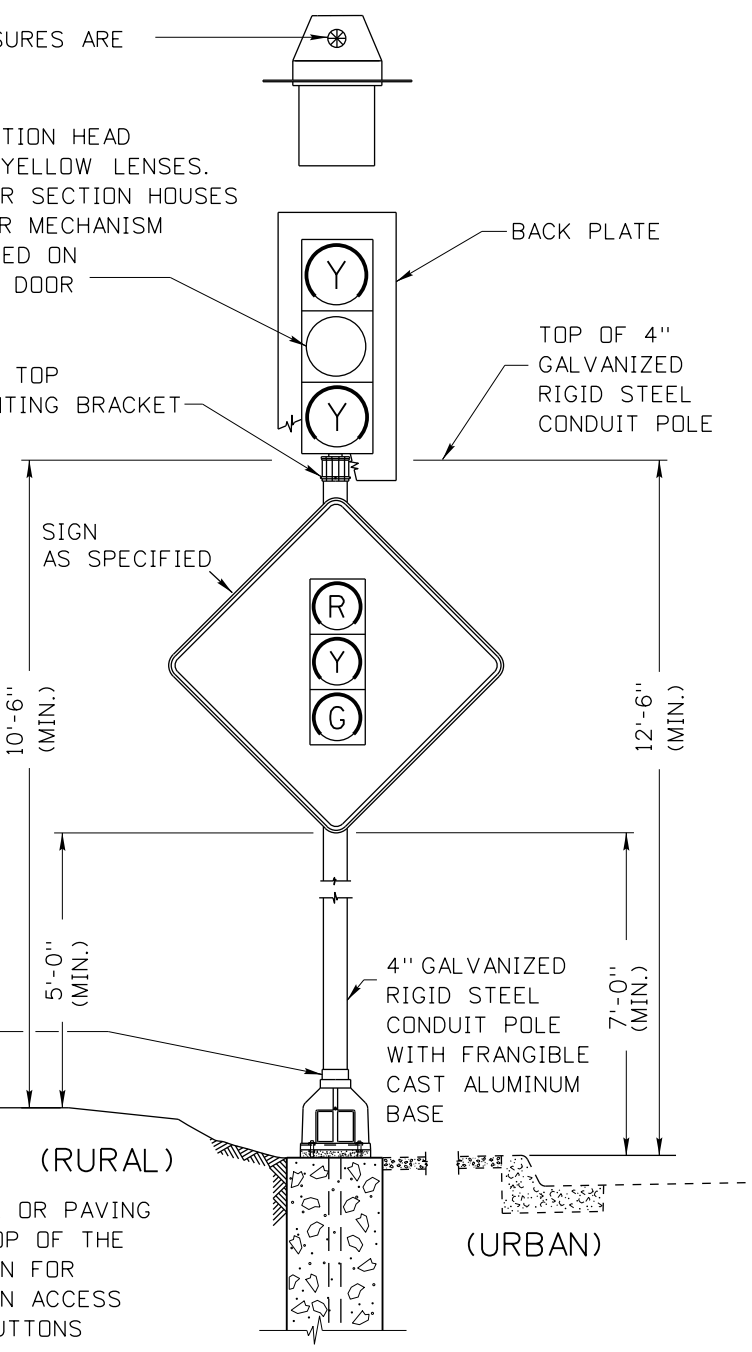

HAZARD IDENTIFICATION BEACON

- NOTES:
1. THIS DRAWING SHOWS TYPICAL INSTALLATION DETAILS ONLY. SEE PLAN SHEETS FOR QUANTITY AND LOCATION OF SIGNAL AND LIGHTING COMPONENTS TO BE INSTALLED.
  2. ORIENTATION OF SIGNAL COMPONENTS SHALL BE AS SHOWN UNLESS OTHERWISE SPECIFIED ON THE PLAN SHEETS.
  3. SEE STANDARD DRAWING 656-3 FOR FOUNDATION DETAILS.
  4. ALL SIGNAL COMPONENTS SHALL BE LEVELED AFTER THE POLE HAS BEEN PLUMBED.
  5. SPECIFIC LOCATION OF EACH POLE INSTALLATION SHALL BE AS INDICATED ON THE PROJECT PLAN SHEETS.
  6. ALL CONDUIT ELBOWS USED IN CONCRETE BASES SHALL BE STEEL.
  7. STEEL CONDUIT SHALL BE USED TO EXTEND ELBOWS BEYOND CONCRETE FOUNDATION.
  8. SPARE STUB OUTS SHALL BE TERMINATED WITH A STEEL COUPLING AND PLASTIC PUSH OUTS AT BOTH ENDS.

PEDESTRIAN PUSHBUTTON MOUNTING  
PEDESTRIAN PUSHBUTTON ASSEMBLIES ARE TO BE MOUNTED AS PER MANUFACTURER'S INSTRUCTIONS.

REVISIONS							
NO.	DATE	BY	NO.	DATE	BY	NO.	DATE
1	12-94	HEB	6	04-14	HEB		
2	08-06	NQB	7	12-16	HEB		
3	12-07	HEB					
4	07-09	HEB					
5	07-10	HEB					

SCALES SHOWN ARE FOR 11" X 17" PRINTS ONLY  
CADD FILE NAME: 656-2\_1216.dgn  
DRAWING DATE: AUGUST, 1994

**IDAHO TRANSPORTATION DEPARTMENT**



BOISE IDAHO

ORIGINAL SIGNED BY: TED MASON  
DESIGN/TRAFFIC SERVICES ENGINEER

STANDARD DRAWING  
**FRANGIBLE CAST BASE TRAFFIC SIGNAL POLES**  
REQUIRES STD. DWG. 656-15

ORIGINAL STORED AT: ITD, Headquarters 3311 West State Boise, Idaho  
**English**  
STANDARD DRAWING NO. **656-2**  
SHEET 1 OF 1

ORIGINAL SIGNED BY: ROBERT KOEBERLEIN  
DATE ORIGINAL SIGNED: DECEMBER 5, 2016