

CONCRETE COLLAR PLAN

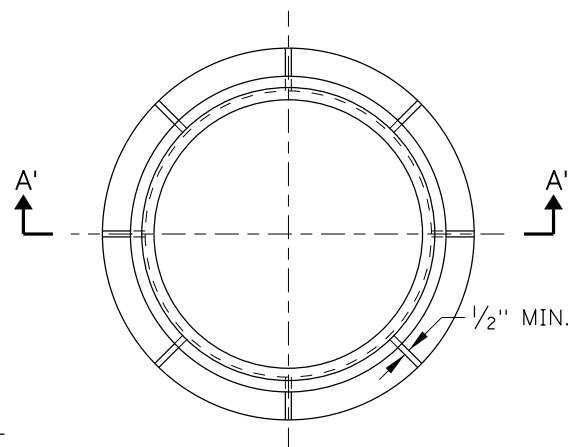

FRAME PLAN

COVER PLAN - TOP HALF VIEW

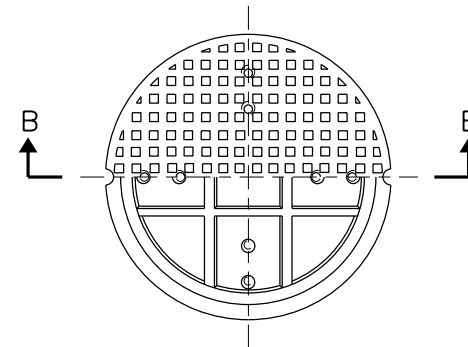

COVER PLAN - BOTTOM HALF VIEW

STANDARD MANHOLE FRAME BASIC DIMENSIONS	
A	24 1/8"
B	1"
C	21" MIN.
D	31" MIN.
E	5"
STANDARD MANHOLE COVER BASIC DIMENSIONS	
A'	23 7/8"
* B'	1"
C'	20"

\* B' MANHOLE FRAME BOTTOM TO FIT INSIDE ANOTHER FRAME LID OPENING

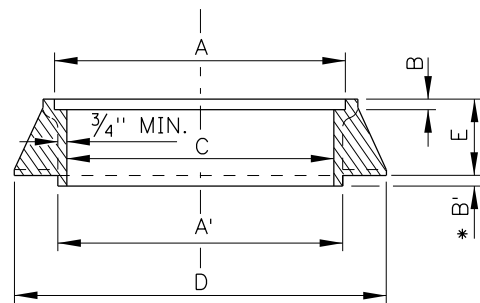

SECTION A-A'

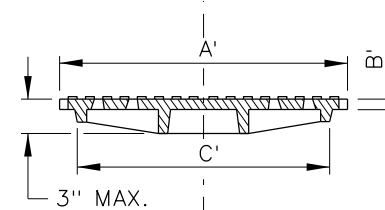

SECTION B-B

NOTES

1. THE MINIMUM WEIGHT OF THE FRAMES SHALL BE 150LBS. AND THE MINIMUM WEIGHT OF COVERS SHALL BE 110LBS. THESE FRAMES AND COVERS ARE TO BE USED IN ALL TRAFFIC AND NON-TRAFFIC AREAS.
2. FRAMES AND COVERS SHALL CONFORM TO AASHTO M 306-05 AND SHALL BE MADE OF CLASS 35B GRAY IRON.
3. THE LAYOUT AND DIMENSIONS OF THE WEBS ARE TYPICAL MINIMUMS. PROPRIETARY MANHOLE COVERS WITHOUT WEBS ARE ACCEPTABLE PROVIDED THEY MEET AASHTO M 306-05 AND MINIMUM WEIGHT REQUIREMENTS. ALL COVER DESIGNS SHALL BE PROVIDED WITH AN ANTI-SHIFT SKIRT THAT EXTENDS A MINIMUM OF 1" BELOW THE COVER SEAT.
4. THE SURFACE SHOWN IS FOR ILLUSTRATION ONLY. ANY SURFACE DESIGN, OTHER THAN SMOOTH, MAY BE USED UPON APPROVAL.
5. A CAST-IN-PLACE CONCRETE COLLAR SHALL BE PLACED AROUND THE MANHOLE FRAME UNLESS OTHERWISE DIRECTED. THE CONCRETE COLLAR SHALL MEET THE REQUIREMENTS OF SECTION 609 - MINOR STRUCTURES, OF THE CURRENT ITD STANDARD SPECIFICATIONS FOR HIGHWAY CONSTRUCTION.
6. THE CONCRETE COLLAR SHALL BE PLACED TO THE TOP OF THE MANHOLE/STRUCTURE OR HAVE A MINIMUM THICKNESS OF 9". WHEN THE CONCRETE COLLAR IS PLACED ON TOP OF A MANHOLE/STRUCTURE THE THICKNESS SHALL NOT BE LESS THAN THE "F DIMENSION" OF THE FRAME. THE VERTICAL METAL REINFORCEMENT LENGTHS MAY BE ADJUSTED WHEN THE COLLAR IS PLACED ON TOP OF A STRUCTURE/MANHOLE.
7. USE OF A PLASTIC MANHOLE FRAME SUPPORT, I.E. WHIRLY-GIG OR COMPARABLE DEVICE, IS AN ACCEPTABLE CONSTRUCTION OPTION.
8. NOT TO SCALE.

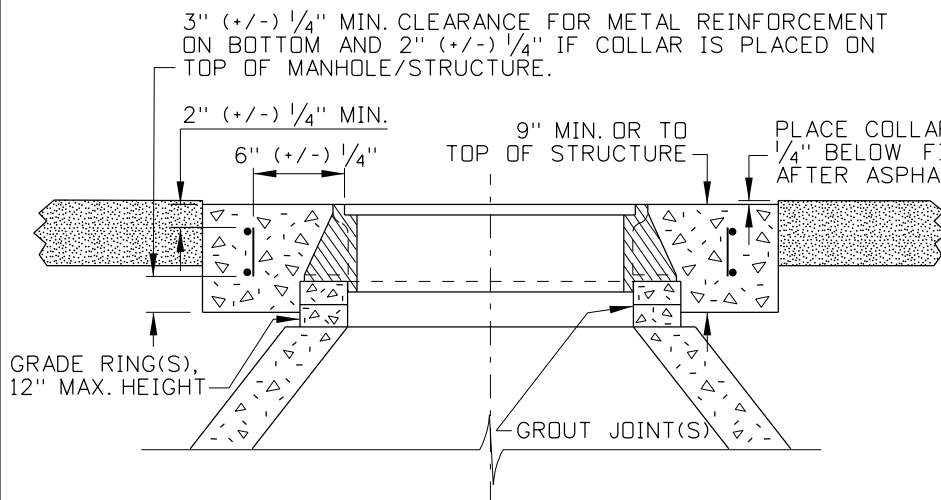

MANHOLE FRAME SUPPORTED WITH CONC. COLLAR RINGS (SEE NOTE NO. 6)

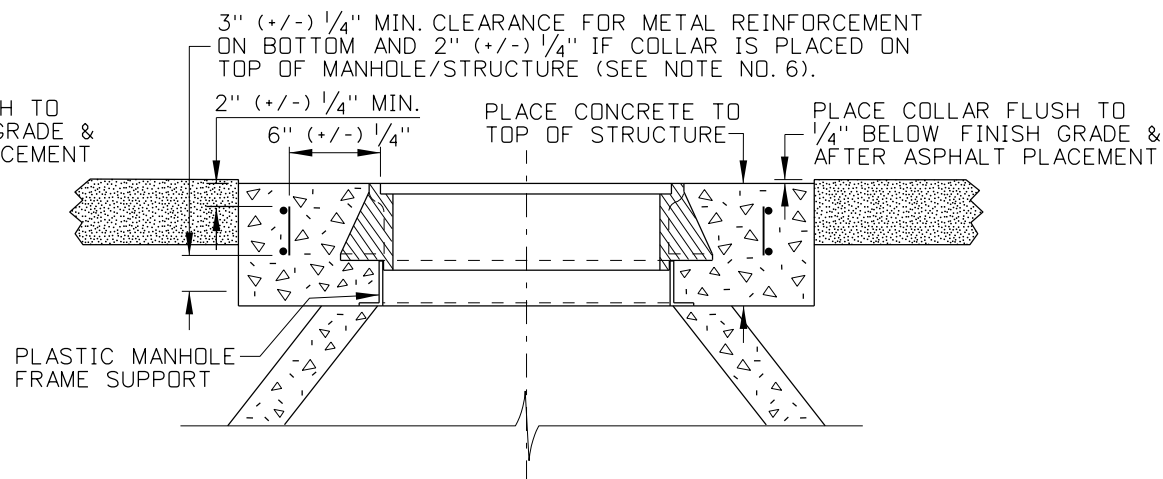

PLASTIC MANHOLE FRAME SUPPORT (SEE NOTE NO. 7)

SECTION A-A

REVISIONS							
NO.	DATE	BY	NO.	DATE	BY	NO.	DATE
1	06-61	NS	6	10-05	MSM		
2	02-74		7	06-07	MSM		
3	12-92	MSM	8	09-10	PLR		
4	05-95	MSM					
5	11-01	MSM					

SCALES SHOWN ARE FOR 11" X 17" PRINTS ONLY  
 CADD FILE NAME: e9\_1010.dgn  
 DRAWING DATE: JUNE, 1961

IDAHO TRANSPORTATION DEPARTMENT



BOISE IDAHO

ORIGINAL SIGNED BY: LOREN THOMAS  
 ASSISTANT CHIEF ENGINEER (DEVELOPMENT)  
 ORIGINAL SIGNED BY: TOM COLE  
 CHIEF ENGINEER

STANDARD DRAWING

STANDARD MANHOLE FRAME, COVER, & CONCRETE COLLAR

English

STANDARD DRAWING NO.

E-9

SHEET 1 OF 1

ORIGINAL STORED AT: ITD, Headquarters 3311 West State Boise, Idaho

ORIGINAL SIGNED BY: TED E. MASDN  
 DATE ORIGINAL SIGNED: OCTOBER 26, 2010