

INSTALLATION DETAIL

SIGN POST DETAILS TABLE

POST TYPE	POST SIZE	EMBEDMENT DEPTH A	NOTCH DEPTH	BREAKAWAY HOLE SIZE
D-1	4"x4"	3'-6"	—	—
D-2	4"x6"	4'-0"	1 3/4"	1 1/2" DIA.
D-3	6"x6"	5'-0"	1 3/4"	2" DIA.
D-4	6"x8"	6'-0"	2 1/2"	3" DIA.
D-5	8"x8"	6'-0"	—	SEE NOTE 2

SIGN POST DETAILS TABLE NOTES:

- 7'-0" MIN. CLEAR DISTANCE BETWEEN 6"x6" POSTS OR LARGER. FULL WIDTH SAW CUT NOTCHES ARE REQUIRED ON ALL TWO POST INSTALLATIONS. OMIT NOTCH FOR SINGLE POST INSTALLATIONS.
- NON-BREAKAWAY POST: THE D-5 (8" x 8") POST IS ONLY APPROVED FOR USE OUTSIDE THE CLEAR ZONE OR WITHIN CLEAR ZONE WHEN PROTECTED BY GUARD RAIL OR OTHER NCHRP-350 OR MASH DEVICES.

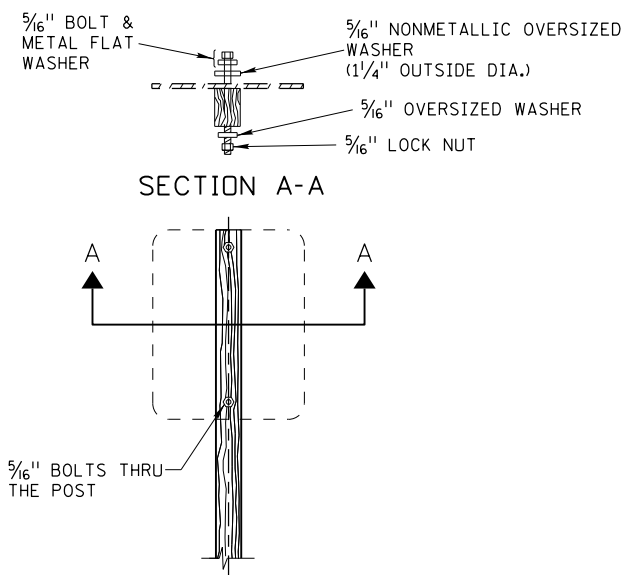

TYPICAL MOUNTING FOR SIGNS WITHOUT BRACE ANGLES

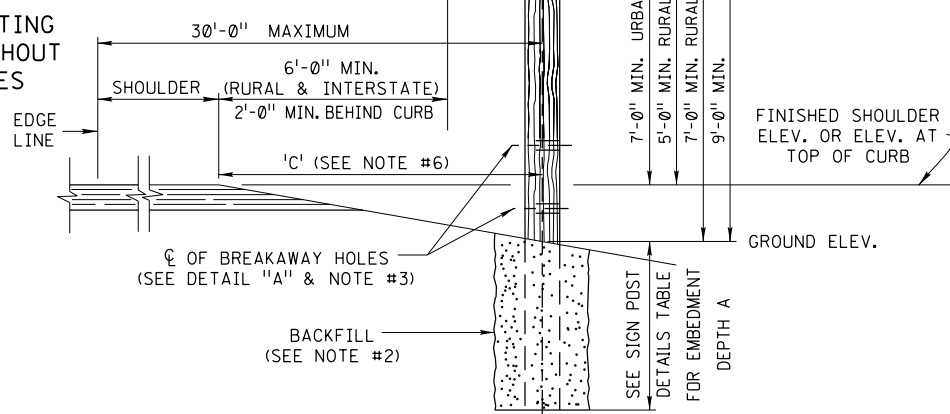

INSTALLATION DETAIL

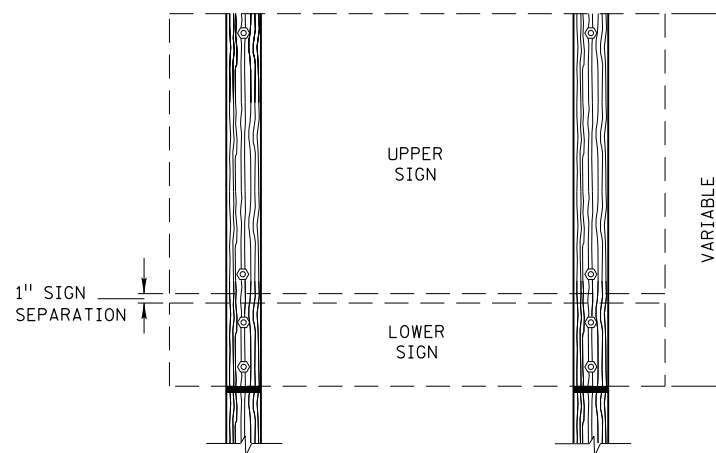

TYPICAL SHEET ALUMINUM OR PLYWOOD SIGNS MOUNTED ON WOOD POSTS

SHEET ALUMINUM SIGNS MAY REQUIRE THE BRACE ANGLES.

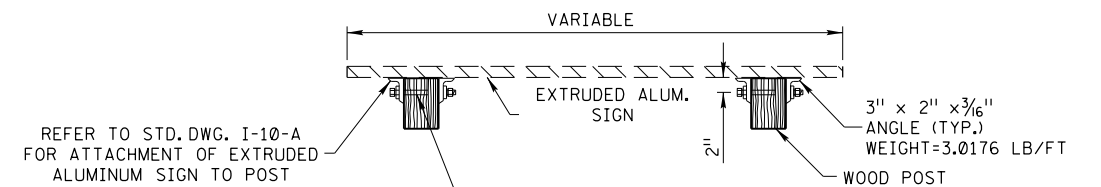

SECTION B-B

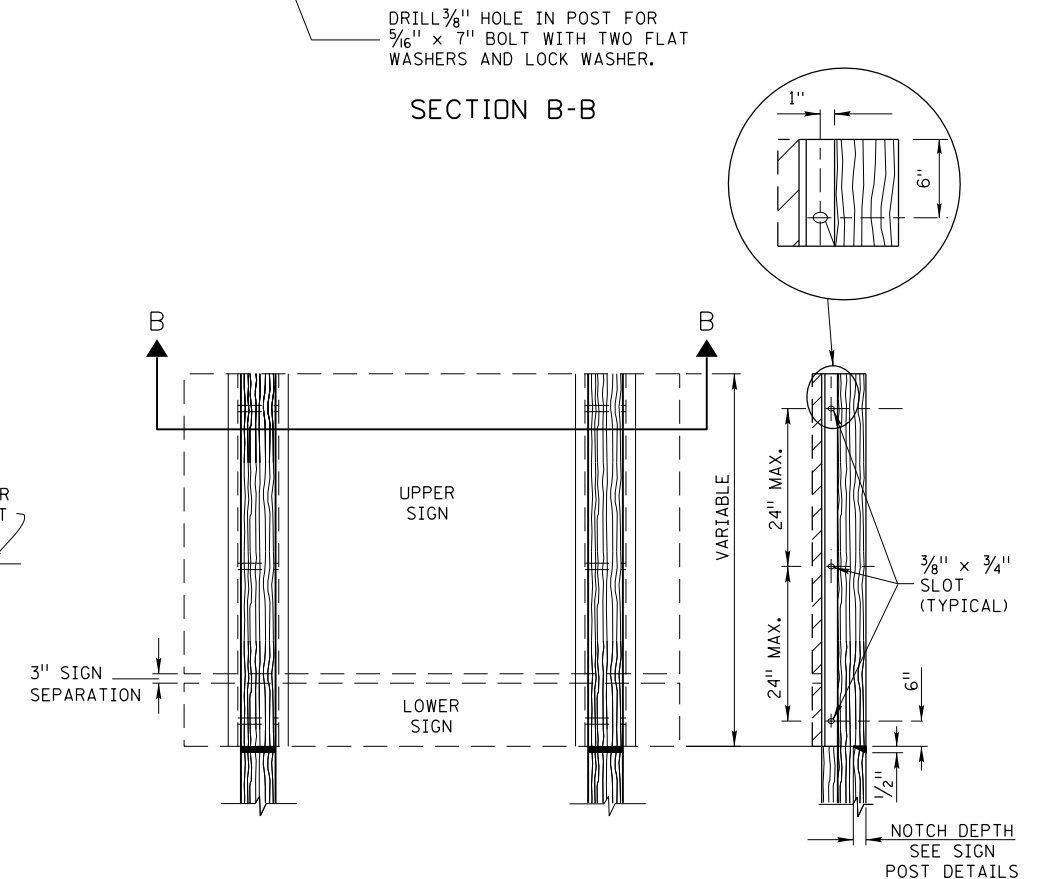

TYPICAL EXTRUDED ALUMINUM SIGN MOUNTED ON WOOD POSTS

ANGLES ARE REQUIRED FOR MOUNTING EXTRUDED ALUMINUM PANEL SIGNS.

NOTES:

- PLACE LONG DIMENSION OF POST CROSS SECTION PERPENDICULAR TO THE SIGN FACE.
- BACKFILL SHALL BE APPROVED GRANULAR BORROW.
- BREAKAWAY HOLES SHALL BE FIELD DRILLED. POSTS 4"x6" AND LARGER REQUIRE BREAKAWAY HOLES. THE BREAKAWAY HOLES SHALL BE DRILLED PARALLEL TO THE SIGN FACE.
- IF THE LOWER SIGN IS AN OBJECT MARKER, THE DIMENSION SHALL BE 4'-0".
- POSTS SHALL BE PRESSURE TREATED ACCORDING TO SECTION 710.09.
- SEE SIGNING ERECTION SPECIFICATIONS SHEET IN PLANS FOR 'C' DIMENSION.

REVISIONS							
NO.	DATE	BY	NO.	DATE	BY	NO.	DATE
1	08-96	HEB					
2	12-13	HEB					

SCALES SHOWN ARE FOR 11" X 17" PRINTS ONLY  
 CADD FILE NAME: i8e\_1213.dgn  
 DRAWING DATE: NOVEMBER, 1991

**IDAHO TRANSPORTATION DEPARTMENT**

BOISE IDAHO

ORIGINAL SIGNED BY: RYAN LANCASTER for  
 DESIGN/TRAFFIC SERVICES ENGINEER

STANDARD DRAWING  
**BREAKAWAY SIGN POSTS TYPE D**

English  
 STANDARD DRAWING NO.  
**I-8-E**  
 SHEET 1 OF 1

ORIGINAL STORED AT: ITD, Headquarters 3311 West State Boise, Idaho

ORIGINAL SIGNED BY:  
 DATE: ORIGINAL SIGNED:  
 DECEMBER 6, 2013