

SECTION A-A

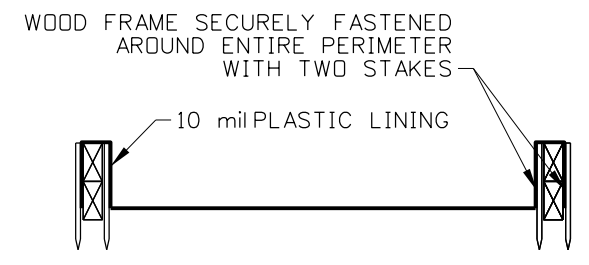

SECTION B-B

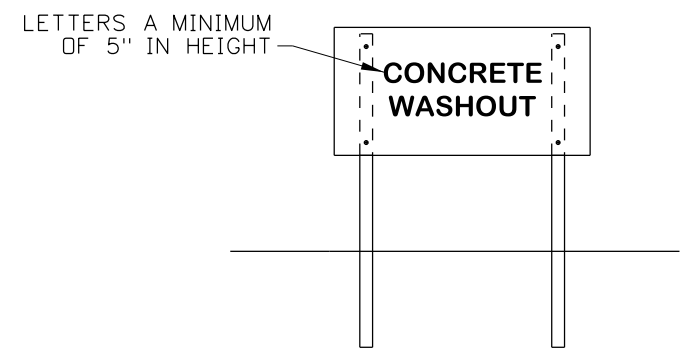

CONCRETE WASHOUT SIGN DETAIL
(SEE NOTE NO. 2)

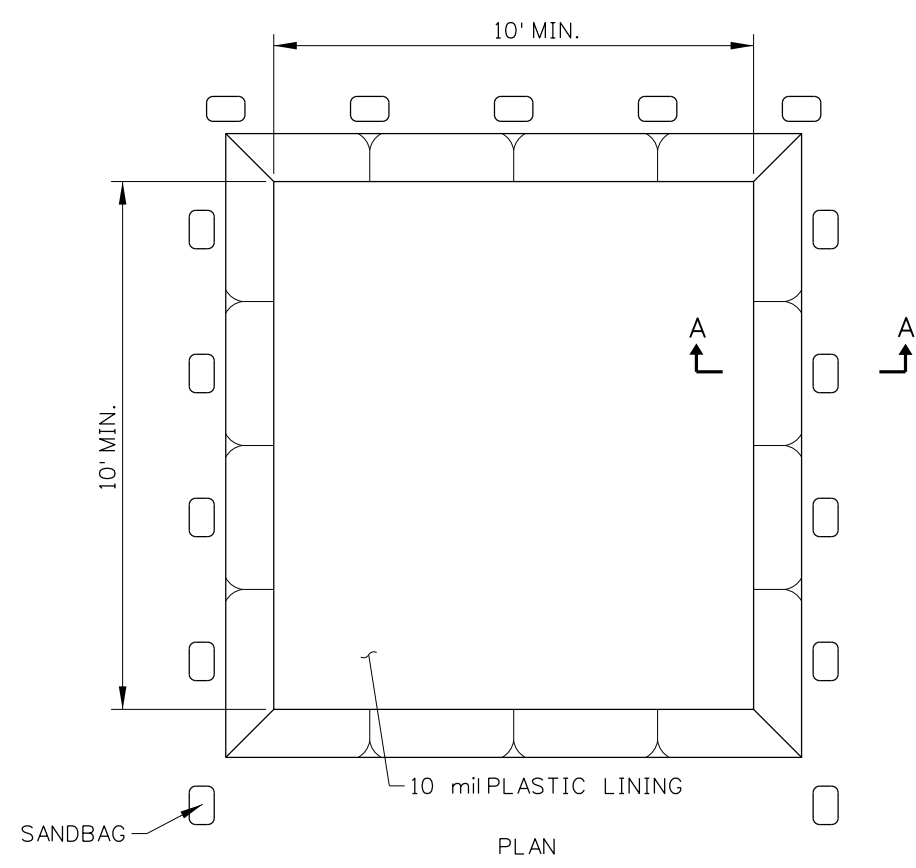

TYPE BELOW GRADE

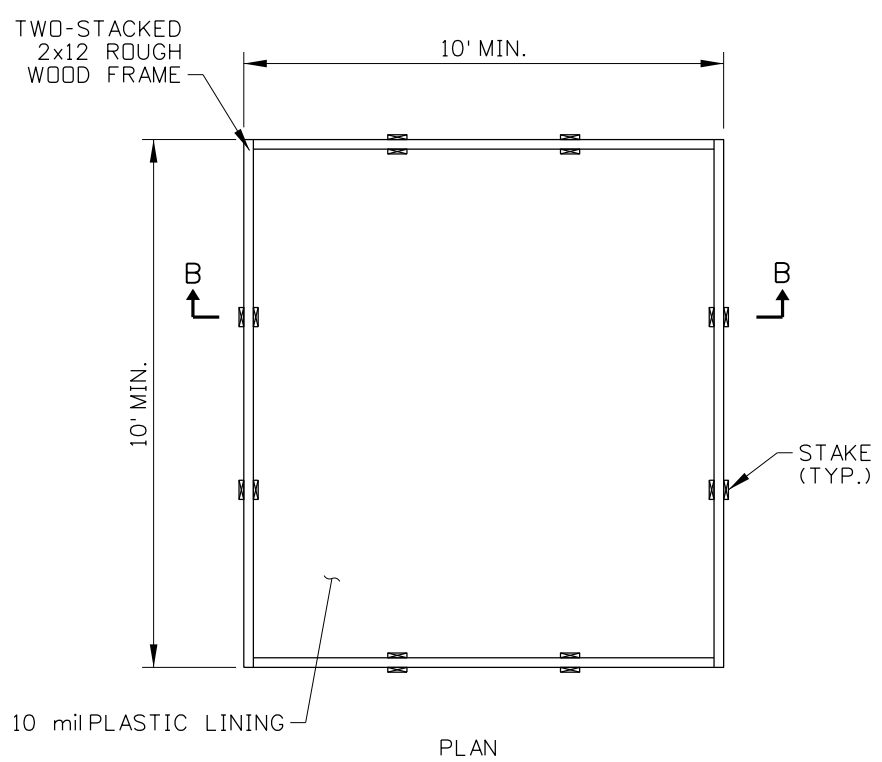

TYPE ABOVE GRADE

NOTES

1. USE THIS DRAWING IN CONJUNCTION WITH THE ITD BEST MANAGEMENT PRACTICES (BMP) MANUAL.
2. ACTUAL LAYOUT DETERMINED IN THE FIELD
3. INSTALL THE CONCRETE WASHOUT SIGN WITHIN 30 FEET OF THE TEMPORARY CONCRETE WASHOUT FACILITY.
4. USE OF PREFABRICATED TEMPORARY WASHOUT MAY ONLY BE USED ON APPROVAL BY THE ENGINEER.
5. NOT TO SCALE.

ORIGINAL STORED AT: ITD, Headquarters 3311 West State Boise, Idaho

ORIGINAL SIGNED BY: J. CALEB LAKEY
DATE ORIGINAL SIGNED: NOVEMBER 20, 2013

REVISIONS								
NO.	DATE	BY	NO.	DATE	BY	NO.	DATE	BY
1	11-13	RDL						

SCALES SHOWN ARE FOR 11" X 17" PRINTS ONLY
CADD FILE NAME: p5b_1113.dgn
DRAWING DATE: OCTOBER, 2010

IDAHO TRANSPORTATION DEPARTMENT



BOISE IDAHO

ORIGINAL SIGNED BY: TOM COLE for HIGHWAYS PROGRAM OVERSIGHT ENGINEER
ORIGINAL SIGNED BY: TOM COLE CHIEF ENGINEER

STANDARD DRAWING
TEMPORARY CONCRETE WASHOUT

English
STANDARD DRAWING NO. P-5-B
SHEET 1 OF 1